



Sistema de Gestión  
de Calidad  
Certificado en  
ISO 9001

# Advanced

SISTEMA MODULAR

Catálogo  
**2025**

 **ISENTEC**

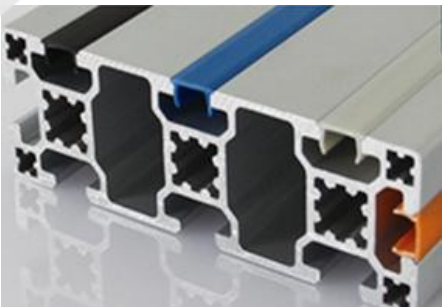

# Advanced

— Sistema Modular —



Fundados y ubicados en Tijuana, B.C. en 2010, con presencia en San Diego, CA, somos una empresa líder en el sector de la distribución a toda la república mexicana de insumos industriales, así como expertos en proyectos de ingeniería e infraestructura.

Hemos ampliado nuestro alcance de certificación ISO 9001-2015 el día 12 de Junio del 2024, ahora a Servicio de venta de perfil estructural e insumos industriales, así como el diseño y manufactura de proyectos estructurales. En TJS DISTRIBUIDORES ofrecemos soluciones para todas las tareas de diseño y construcción de sistemas modulares, garantizando servicio, calidad y precio.

Contáctanos para que un experto pueda ayudarte con el diseño de tus estructuras, creación de proyectos, montaje y mucho más.





INFRAESTRUCTURA



INSUMOS  
INDUSTRIALES



ALUMINIO  
ESTRUCTURAL



SISTEMA DE  
ESTRUCTURA TUBULAR



MOBILIARIO



CUBIERTAS  
ESPECIALES

# ÍNDICE

Perfil estructural .....	02
Tornillería y Herraje.....	26
Elementos de Unión.....	42
Accesorios de Perfiles.....	88
Elementos de Piso.....	96
Elementos para instalación de paneles .....	140
Elementos para puertas y ventanas .....	150
Accesorios adicionales .....	181
Tipos de perforación .....	200

## PG15- PG20

### Perfil Estructural de Aluminio



**15x15 2 Slots**  
1.11.15.015015.02  
pag. 04



**15x30 3 Slots**  
1.11.15.015030.03  
pag. 04



**20x20 R90 Slots**  
1.11.20.020020.R90.02  
pag. 04



**20x20 4 Slots**  
1.11.20.020020.04  
pag. 04



**20x40 6 Slots**  
1.11.20.020040.06  
pag. 04



**20x60 8 Slots**  
1.11.20.020060.08  
pag. 04



**20x80 10 Slots**  
1.11.20.020080.10  
pag. 05



**40x40 8 Slots**  
1.11.20.040040.08  
pag. 05

## PG30

### Perfil Estructural de Aluminio



**15x90 7 Slots**  
1.11.30.015090.07  
pag. 07



**30x30 R45 2 Slots**  
1.11.30.030030.R45.02  
pag. 07



**30x30 R90 2 Slots**  
1.11.30.030030.R90.02  
pag. 07



**30x30 2 Slots Type A**  
1.11.30.030030.02A  
pag. 07



**30x30 2 Slots Type B**  
1.11.30.030030.02B  
pag. 07



**30x30 3 Slots**  
1.11.30.030030.03  
pag. 07



**30x30 4 Slots Light**  
ADV 30X30-0.667/M12  
pag. 07



**30x30 4 Slots**  
1.11.30.030030.04  
pag. 07



**30x60 6 Slots**  
ADV 30X60-1.523/M12  
pag. 07



**30x90 8 Slots**  
1.11.30.030090.08  
pag. 07



**30x120 10 Slots**  
1.11.30.030120.10  
pag. 08



**30x150 12 Slots**  
1.11.30.030150.12  
pag. 08

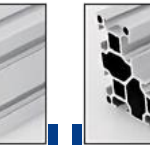

**60x60 8 Slots**  
1.11.30.060060.08  
pag. 08

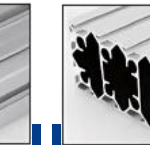

**60x60 L 8 Slots**  
1.11.30.060060L.08  
pag. 09

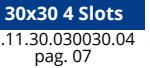

**60x120 12 Slots**  
1.11.30.060120.12  
pag. 09

## PG40

### Perfil Estructural de Aluminio



**40x40 R45 2 Slots**  
1.11.40.040040.R45.02  
pag. 11



**40x40 R90 2 Slots**  
1.11.40.040040.R90.02  
pag. 11



**40x40 T45 2 Slots**  
1.11.40.040040.T45.02  
pag. 11



**40x40 1 Slot**  
1.11.40.040040.01  
pag. 11



**40x40 2 Slots Type A**  
1.11.40.040040.02A  
pag. 11



**40x40 2 Slots Type B**  
1.11.40.040040.02B  
pag. 11



**40x40 3 Slots**  
1.11.40.040040.03  
pag. 11



**40x40 4 Slots Super Light**  
1.11.40.040040.04SL  
pag. 11



**40x40 4 Slots Light**  
ADV 40X40-1.406/M14  
pag. 12



**40x40 4 Slots**  
1.11.40.040040.04  
pag. 13



**40x40 4 Slots Heavy**  
1.11.40.040040.04H  
pag. 13



**40x60 4 Slots**  
1.11.40.040040.04  
pag. 13



**40x80 6 Slots Super Light**  
1.11.40.040080.06SL  
pag. 13



**40x80 6 Slots Light**  
ADV 40X80-2.465/M14  
pag. 13

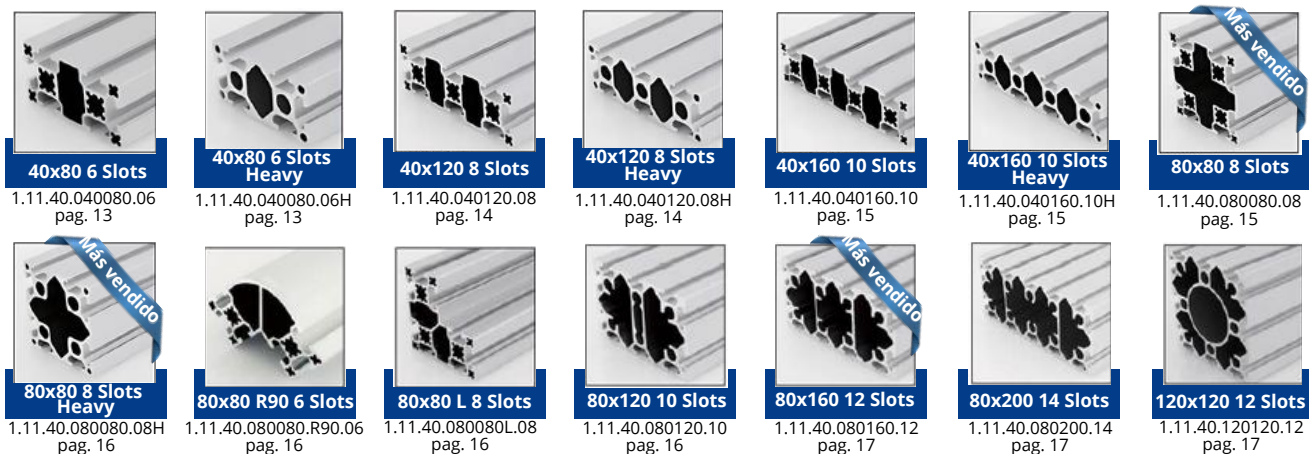

## PG45-PG50-PG60

### Perfil Estructural de Aluminio

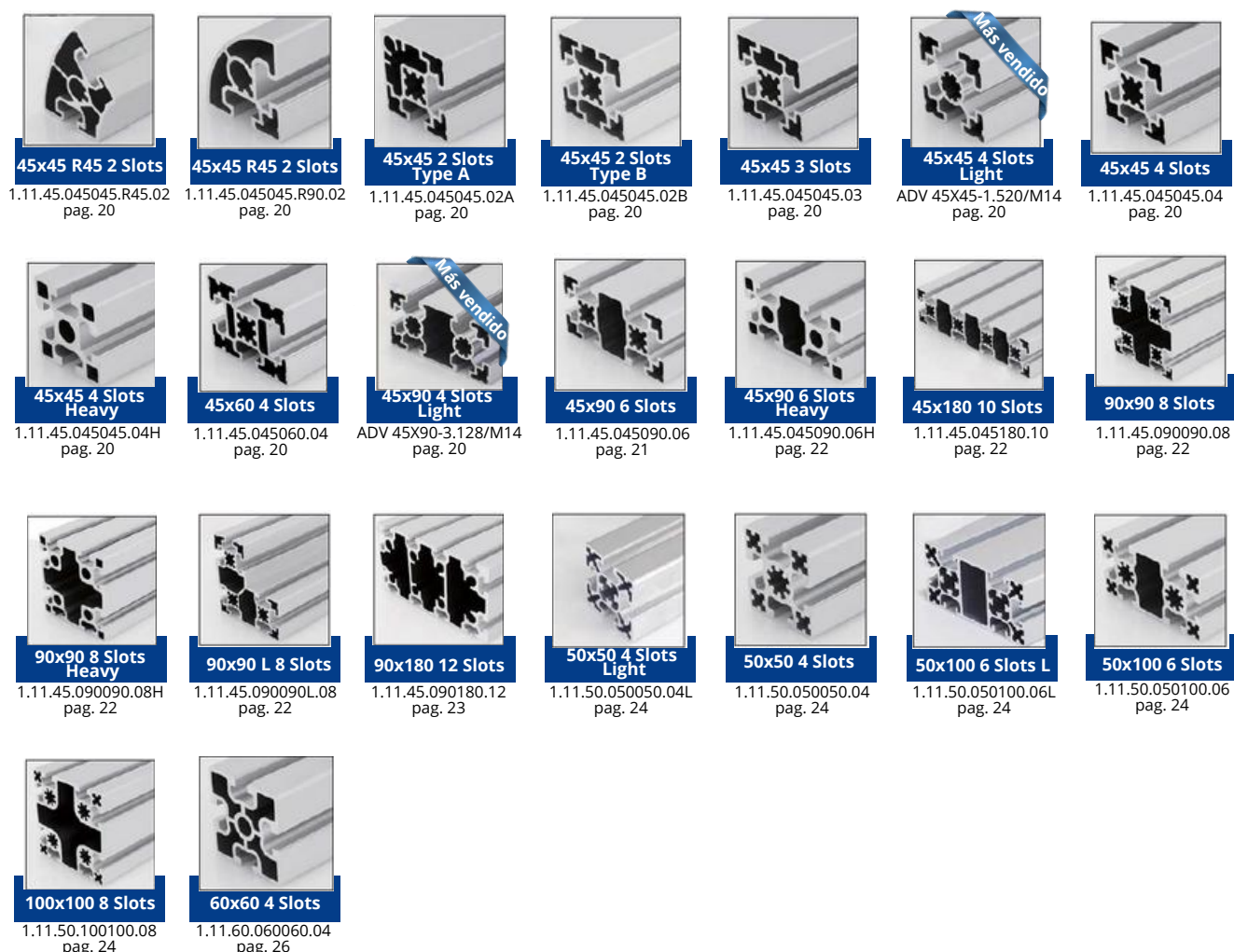

## TORNILLERÍA Y HERRAJE



**Pre-set Nut**

2.11.06M4  
pag. 28



**Square Nut**

2.12.08.M4  
pag. 30



**T Nut**

2.21.06.M4  
pag. 32



**Subsequent Nut**

2.31.08.M4  
pag. 34



**Anti-torsion  
Subsequent Nut**

2.32.08.M6  
pag. 36



**T Bolt**

2.41.08.16  
pag. 38



**Hole Reducer  
Bolt**

2.51.10.06  
pag. 40

## ELEMENTOS DE UNIÓN



**Anchor Connector**

3.11.30.01  
pag. 44



**Die Cast Bracket**

3.21.20.2020  
pag. 49



**Angle Profile  
Bracket**

3.31.35.20.40  
pag. 55



**Inner Bracket**

3.41.06A  
pag. 68



**Linear Bar**

3.51.06  
pag. 70



**Joining Plate**

3.52.08  
pag. 72



**Butt Connector**

3.61.08  
pag. 79



**End Connector**

3.71.30  
pag. 81



**Screw Connector**

3.81.06  
pag. 83



**Cubic Connector**

3.91.4545.02  
pag. 85

## ACCESORIOS DE PERFIL



**End Cap**

4.11.15.1515  
pag. 89



**T slot cover**

4.21.06.BK  
pag. 94

## ELEMENTOS DE PISO



**Base Plate**

5.11.4080  
pag. 97



**Base Plate**

5.12.40ST  
pag. 100



**Leveling Foot**

5.21.60.12.90  
pag. 102



**Mounting Plate**

5.31.40.4040  
pag. 114



**Mounting Plate**

5.32.40.4040  
pag. 116



**Mounting Plate**

5.33.40.4040  
pag. 119



**Castor Plate**

5.34.30.STA  
pag.123



**Castor**

5.41.63.M12  
pag. 129



**Base Angle**

5.51.L  
pag. 132



**L Base**

5.52.10  
pag. 134



**Foot and Castor**

5.61.L  
pag. 136



**Leveling Castor**

5.62.60F  
pag. 138

## ELEMENTOS PARA INSTALACIÓN DE PÁNELES



**T Slot Reducing Profile**

6.11.06  
pag. 141



**Panel Installation Block**

6.21.06  
pag. 143



**Panel Mounting Strip**

6.31.08.02  
pag. 146



**Mounting Block**

6.41.08.01  
pag. 148

## ELEMENTOS PARA PUERTAS Y VENTAS



**Handle**

7.11.90.06.BE  
pag. 151



**Guard Wing Handle**

7.12.95.08.BE  
pag. 153



**Aluminum Handle**

7.13.P.GY  
pag. 155



**Hinge**

7.21.30.30  
pag. 157



**Hinge**

7.23.20.20  
pag. 159



**Hinge**

7.24.30.30.30  
pag. 163



**Hinge**

7.27.30.30  
pag. 166

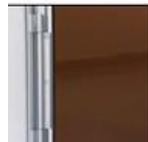

**Hinge**

7.28.30.30  
pag. 168



**Lock**

7.31  
pag. 170



**Magnet Catch**

7.41.14  
pag. 174



**Door Lock**

7.42.30.3040  
pag. 177



**Sliding Door Profile**

7.51.08  
pag. 179

## ACCESORIOS ADICIONALES



**Suspender Glinder**

8.11.08  
pag. 182



**Swivel Angle Plate**

8.21.30  
pag. 184



**Potential Equaliser Nut**

8.22.08.M4  
pag. 186



**Joint**

8.31.4040A  
pag. 188



**Frame Joint**

8.41.4040  
pag. 194



**Mounting Adaptor for Roller**

8.51.01A  
pag. 196



**Telescope Unit**

8.61.40.3030.01.ST  
pag. 198

## TIPOS DE PERFORACIÓN

Dowel Bore  
pag. 201

Inner Connector Bore  
pag. 202







Screw Thread Bore  
pag. 203

Cross Bore  
pag. 204

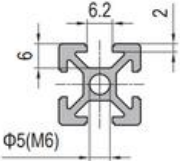
Angle Cut T  
pag. 205

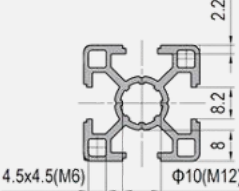
# SLOT CHART

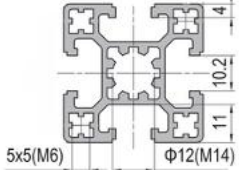
## TABLA DE RANURAS

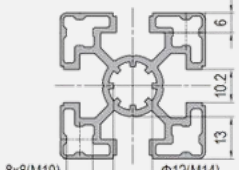
T Slot Symbol Símbolo de ranura	Cross Section Sección cruzada	Core Hole Agujero de centro	Slot Width Ancho de ranura	Slot Depth Profundidad de ranura	Wall Thickness Ancho de Paredes	Profile Group Grupo de perfil
		5.0	6.2	6.0	2.0	<b>PG15</b> <b>PG20</b>
		10.0	8.2	8.0	2.2	<b>PG30</b>
		12.0	10.2	11.0	4.0	<b>PG40</b>
		12.0	10.2	13.0	6.0	<b>PG45</b> <b>PG50</b> <b>PG55</b>



Advanced  
Sistema Modular





# PERFIL DE ALUMINIO ESTRUCTURADO

- ✓ Cortos tiempos de diseño y ejecución
- ✓ Materiales reutilizables
- ✓ Disponibilidad
- ✓ Flexibilidad y adaptación

# PERFIL DE ALUMINIO PG15 - PG20

## Strut Profile



**Material:** 6063-T6  
**Surface:** Anodized 11µM  
**Color:** Silver / Plateado

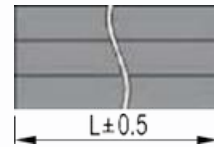

**Effective length:** 5800mm  
 Cut section not anodized.

Perfil estructural PG15 -PG20 con T-slot de 6mm están diseñados para construir instalaciones de poco peso.

Strut Profile PG15 and PG20 featuring 6mm T-slot are designed for constructing light weight assemblies.

PG15-PG20

PG30

PG40

PG45- PG50  
PG60

T Slot Symbol Símbolo de ranura	Cross Section Sección cruzada	Core Hole Agujero de centro	Slot Width Ancho de ranura	Slot Depth Profundidad de ranura	Wall Thickness Ancho de Paredes	Profile Group Grupo de perfil
		5.0	6.2	6.0	2.0	<b>PG15 PG20</b>

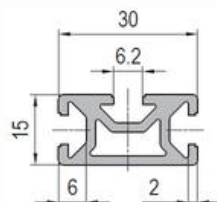
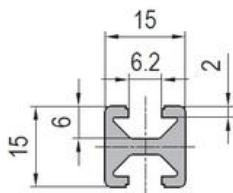

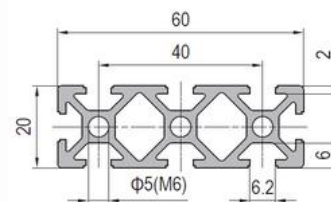
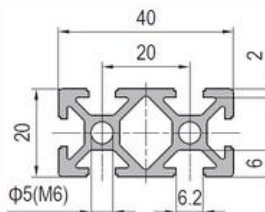
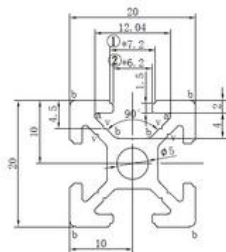
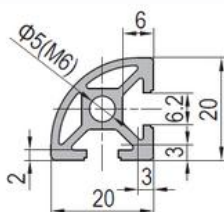

Description	Moment of Inertia Ix(cm <sup>4</sup> )	Moment of Inertia Iy(cm <sup>4</sup> )	Moment of Resistance Wx(cm <sup>4</sup> )	Moment of Resistance Wy(cm <sup>4</sup> )	Mass (Kg/m)	Part No.
Strut Profile PG15 15x15 2 slots	0.2	0.4	0.3	0.5	0.4	1.11.15.015015.02
Strut Profile PG15 15x30 3 slots	0.7	1.8	0.8	1.2	0.6	1.11.15.015030.03

### Elementos de Conexión Compatibles

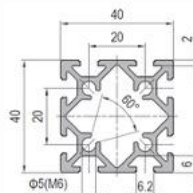
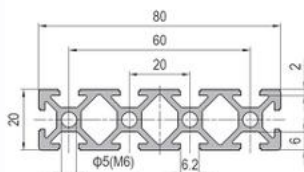



Description	Moment of Inertia $I_x(\text{cm}^4)$	Moment of Inertia $I_y(\text{cm}^4)$	Moment of Resistance $W_x(\text{cm}^3)$	Moment of Resistance $W_y(\text{cm}^3)$	Mass (Kg/m)	Part No.
Strut Profile PG20 20x20 R90 2 slots	0.6	0.6	0.5	0.5	0.45	1.11.20.020020.R90.02
<b>ALUMINUM PROFILE 20MM X 20MM, 0.490/M06 A.PLATED</b>	0.8	0.8	0.8	0.8	0.5	<b>ADV 20X20-0.490/M6</b> 
<b>ALUMINUM PROFILE 20MM X 40MM, 0.881/M06 A.PLATED</b>	1.4	5.1	1.4	2.5	0.9	<b>ADV 20X40-0.881/M6</b> 
Strut Profile PG20 20x60 8 slots	2	15.8	2	5.3	1.3	1.11.20.020060.08
Strut Profile PG20 20x80 10 slots	2.6	35.9	2.6	9	1.7	1.11.20.020080.10
Strut Profile PG20 40x40 8 slots	8.9	8.9	4.5	4.5	1.3	1.11.20.040040.08

### Elementos de Conexión Compatibles

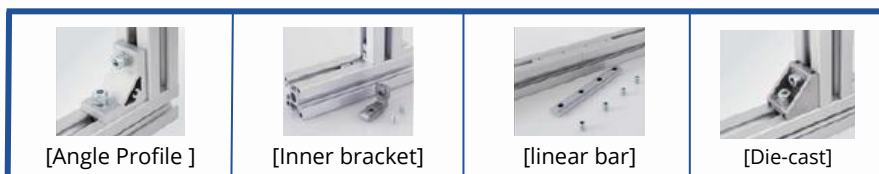

# PERFIL DE ALUMINIO PG30

## Strut Profile



**Material:** 6063-T6  
**Surface:** Anodized 11µM  
**Color:** Silver / Plateado

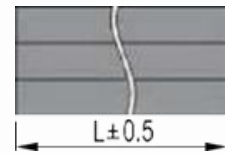

**Effective length:** 5800mm  
 Cut section not anodized.

Perfil estructural PG30 con T-slot de 8.2mm está diseñado para construcciones de mediano peso (Marcos de maquinaria, rieles, estaciones de trabajo, paneles separadores, etc.)

Strut profile PG30, with 8.2mm T-slot, is designed for medium weight structures such as machine frame, trolley, workstation, exhibition frames, and partition frames.

T Slot Symbol Símbolo de ranura	Cross Section Sección cruzada	Core Hole Agujero de centro	Slot Width Ancho de ranura	Slot Depth Profundidad de ranura	Wall Thickness Ancho de Paredes	Profile Group Grupo de perfil
		10.0	8.2	8.0	2.2	<b>PG30</b>

PG15-PG20

PG30

PG40

PG45- PG50  
PG60



15x90 7 slots

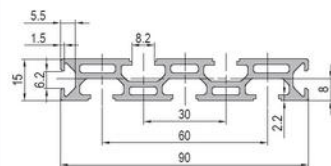

30x30 R45 2 slots

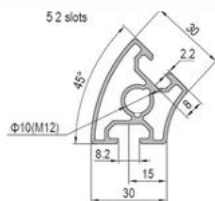

30x30 R90 2 slots

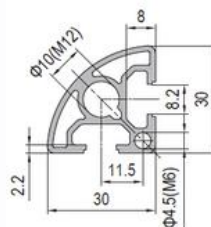

30x30 2 slots Type A

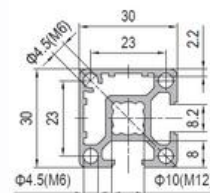

30x30 2 slots Type B

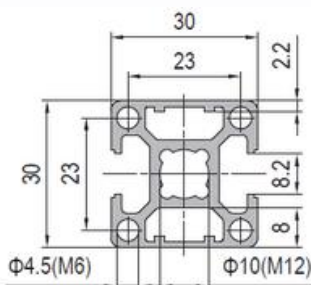

30x30 3 slots

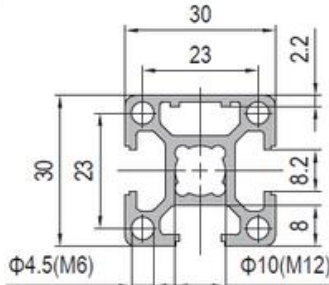

30x30 4 slots Light

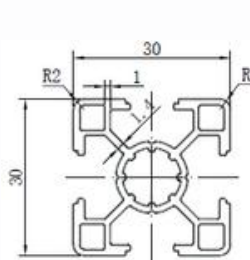

30x30 4 slots

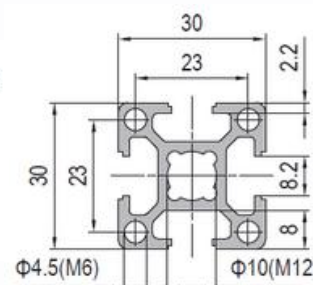

30x60 6 slots

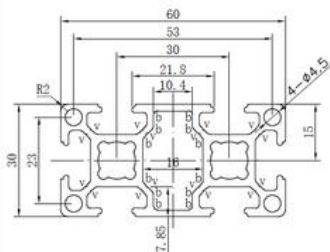

30x90 8 slots

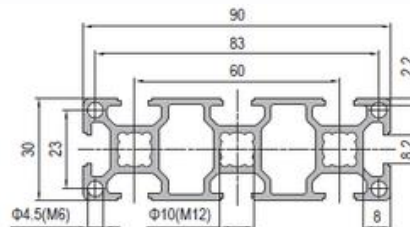



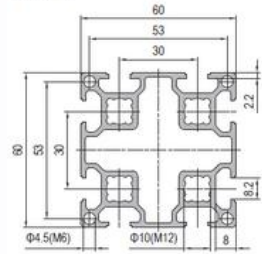
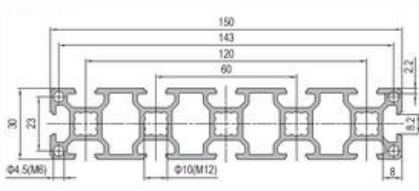
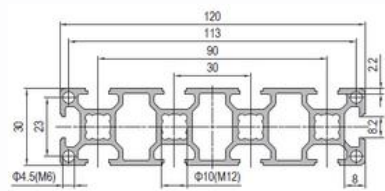

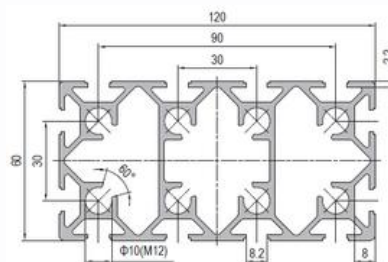
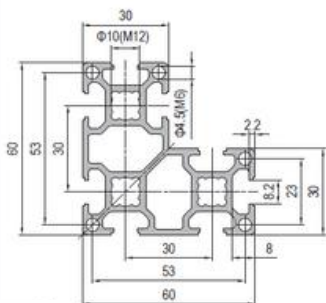

Description	Moment of Inertia $I_x(\text{cm}^4)$	Moment of Inertia $I_y(\text{cm}^4)$	Moment of Resistance $W_x(\text{cm}^3)$	Moment of Resistance $W_y(\text{cm}^3)$	Mass (Kg/m)	Part No.
Strut Profile PG30 15x90 7 slots	1.4	40.4	1.9	9	1.5	1.11.30.015090.07
Strut Profile PG30 30x30 R45 2 slots	4.2	3.1	2.4	1.7	0.8	1.11.30.030030.R45.02
Strut Profile PG30 30x30 R90 2 slots	2.0	2.0	1.5	1.5	0.8	1.11.30.030030.R90.02
Strut Profile PG30 30x30 2 slots Type A	2.9	2.9	2	2	0.9	1.11.30.030030.02A
Strut Profile PG30 30x30 2 slots Type B	2.8	3.2	1.9	2.1	0.9	1.11.30.030030.02B
Strut Profile PG30 30x30 3 slots	3	2.9	2	1.9	0.9	1.11.30.030030.03
<b>ALUMINUM PROFILE 30MM X 30MM 0.667/M12 A.PLATED</b>	2.6	2.6	1.8	1.8	0.8	<b>ADV 30x30-0.667/M12</b>
Strut Profile PG30 30x30 4 slots	2.9	2.9	2	2	0.9	1.11.30.030030.04
<b>ALUMINUM PROFILE 30MM X 60MM, 1.523/M12 A.PLATED</b>	5.3	19.9	3.5	6.7	1.6	<b>ADV 30x60-1.523/M12</b>
Strut Profile PG30 30x90 8 slots	7.7	62	5.1	13.8	2.2	1.11.30.030090.08





Description	Moment of Inertia $I_x(\text{cm}^4)$	Moment of Inertia $I_y(\text{cm}^4)$	Moment of Resistance $W_x(\text{cm}^4)$	Moment of Resistance $W_y(\text{cm}^4)$	Mass (Kg/m)	Part No.
Strut Profile PG30 30x120 10 slots	10.1	139.9	6.7	23.3	2.9	1.11.30.030120.10
Strut Profile PG30 30x150 12 slots	12.5	264.4	8.3	36.3	3.4	1.11.30.030150.12
Strut Profile PG30 60x60 8 slots	35.3	35.3	11.8	11.8	2.5	1.11.30.060060.08
Strut Profile PG30 60x60 L 8 slots	26.4	26.4	10.4	10.4	2.3	1.11.30.060060L.08
Strut Profile PG30 60x120 12 slots	74.7	252.6	24.9	42.1	4.8	1.11.30.060120.12

### Elementos de Conexión Compatibles

 [anchor connector]	 [inner bracket]	 [linear bar]	 [Die-cast]
 [screw connector]		 [Angle Profile ]	

# PERFIL DE ALUMINIO PG40

## Strut Profile



**Material:** 6063-T6  
**Surface:** Anodized 11µM  
**Color:** Silver / Plateado

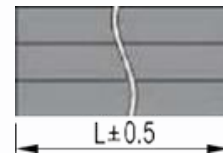

**Effective length:** 5800mm  
 Cut section not anodized.

Perfil estructural PG40 con T-slot de 10.2mm está diseñado para construcciones de mediano y gran peso (Marcos de maquinaria, rieles, estaciones de trabajo, paneles separadores, etc.)

Strut profile PG40, with 10.2mm T-slot, is designed for medium weight structures and heavy loading structures, such as machine frame, workstation, partition, exhibition frames, and machine enclosure, etc.

T Slot Symbol Símbolo de ranura	Cross Section Sección cruzada	Core Hole Agujero de centro	Slot Width Ancho de ranura	Slot Depth Profundidad de ranura	Wall Thickness Ancho de Paredes	Profile Group Grupo de perfil
		12.0	10.2	11.0	4.0	<b>PG40</b>



40x40 R45 2 slots



40x40 R90 2 slots



40x40 T45 2 slots



40x40 1 slots

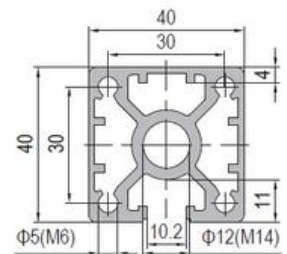
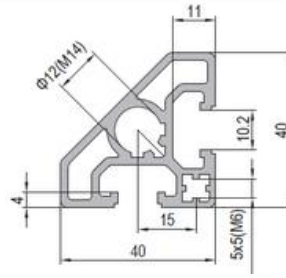
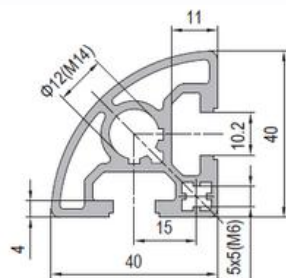
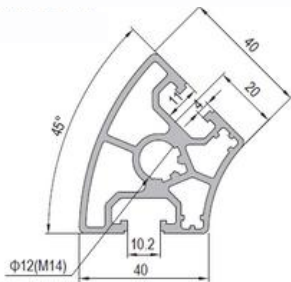

40x40 2 slots Type A



40x40 2 slots Type B



40x40 3 slots



40x40 4 slots  
Super Light

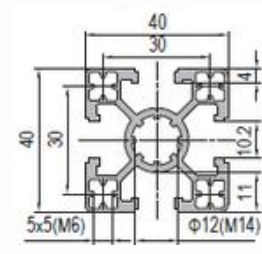
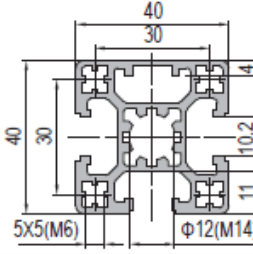
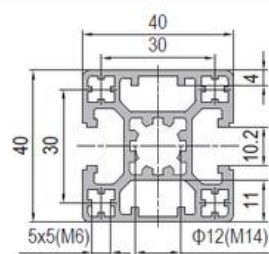
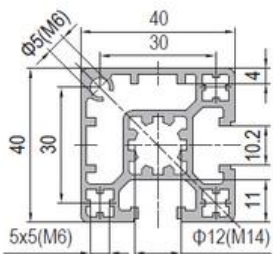

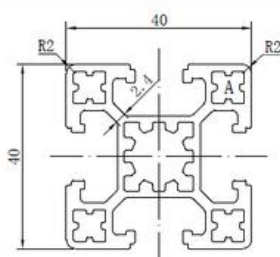

Description	Moment of Inertia $I_x(\text{cm}^4)$	Moment of Inertia $I_y(\text{cm}^4)$	Moment of Resistance $W_x(\text{cm}^3)$	Moment of Resistance $W_y(\text{cm}^3)$	Mass (Kg/m)	Part No.
Strut Profile PG40 40x40 R45 slots	13.6	10.4	5.9	4.2	1.7	1.11.40.040040.R45.02
Strut Profile PG40 40x40 R90 2 slots	6.5	6.5	3.7	3.7	1.3	1.11.40.040040.R90.02
Strut Profile PG40 40x40 T45 2 slots	6.5	6.5	3.25	3.25	1.21	1.11.40.040040.T45.02
Strut Profile PG40 40x40 1 slot	10.4	10.1	5.2	5	1.68	1.11.40.040040.01
Strut Profile PG40 40x40 2 slots Type A	9.6	9.6	4.5	4.5	1.5	1.11.40.040040.02A
Strut Profile PG40 40x40 2 slots Type B	9.6	8.6	4.8	4.3	1.5	1.11.40.040040.02B
Strut Profile PG40 40x40 3 slots	9.1	8.6	4.5	4.3	1.5	1.11.40.040040.03
Strut Profile PG40 40x40 4 slots Super Light	7.3	7.3	3.6	3.6	1.3	1.11.40.040040.04SL
<b>Aluminum Profile 40mm X 40mm 1.40/M14 A. Plated</b>	8.6	8.6	4.3	4.3	1.5	<b>ADV 40X40-1.406/M14</b>





40x40 4 slots



40x40 4 slots Heavy



40x60 4 slots



40x80 6 slots  
Super Light

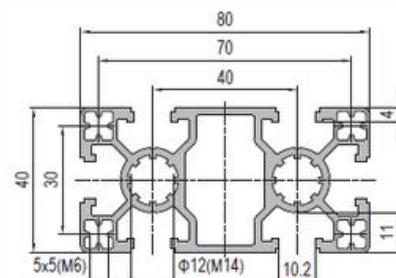
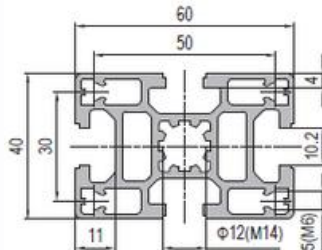
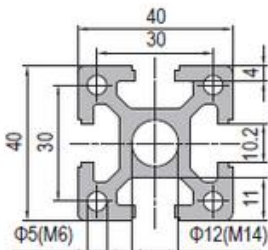
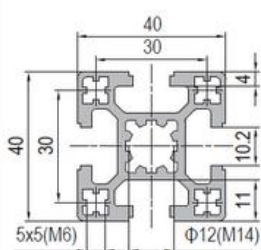

40x80 6 slots Light



40x80 6 slots



40x80 6 slots Heavy

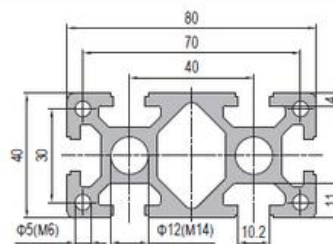
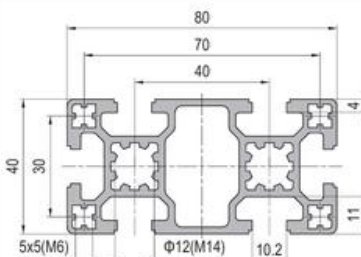
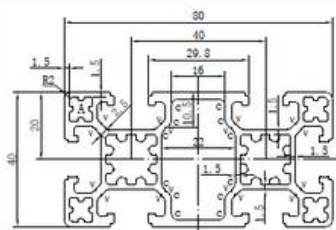

Description	Moment of Inertia $I_x(\text{cm}^4)$	Moment of Inertia $I_y(\text{cm}^4)$	Moment of Resistance $W_x(\text{cm}^3)$	Moment of Resistance $W_y(\text{cm}^3)$	Mass (Kg/m)	Part No.
Strut Profile PG40 40x40 4 slots	9.1	9.1	4.6	4.6	1.6	1.11.40.040040.04
Strut Profile PG40 40x40 4 slots Heavy	11.5	11.5	5.8	5.8	2	1.11.40.040040.04H
Strut Profile PG40 40x60 4 slots	13.3	27.6	6.6	9.2	2.3	1.11.40.040060.04
Strut Profile PG40 40x80 6 slot Super Light	14.3	52	7.2	13	2.3	1.11.40.040080.06SL
<b>ALUMINUM PROFILE 40MM X 80MM, 2.465/M14 A.PLATED</b>	15.8	59.1	7.9	14.8	2.5	<b>ADV 40X80-2.465/M14</b>
Strut Profile PG40 40x80 6 slots	16.6	63.2	8.3	15.8	2.7	1.11.40.040080.06
Strut Profile PG40 40x80 6 slots Heavy	22.2	80.8	11.1	20.2	3.6	1.11.40.040080.06H

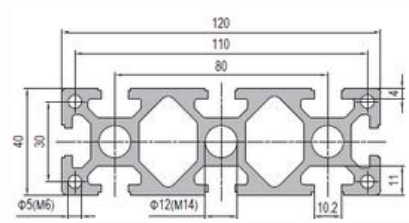
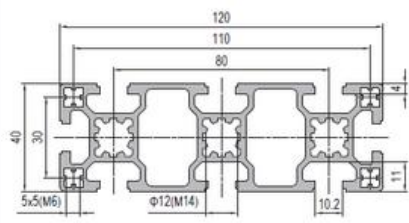

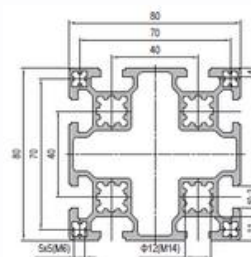
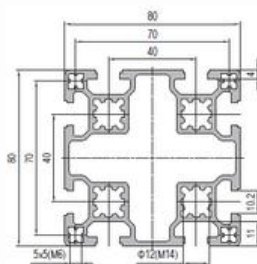
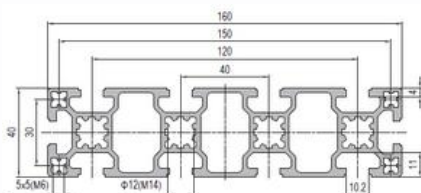

Description	Moment of Inertia $I_x(\text{cm}^4)$	Moment of Inertia $I_y(\text{cm}^4)$	Moment of Resistance $W_x(\text{cm}^3)$	Moment of Resistance $W_y(\text{cm}^3)$	Mass (Kg/m)	Part No.
Strut Profile PG40 40x120 8 slots	24.1	194.8	12.1	32.5	3.8	1.11.40.040120.08
Strut Profile PG40 40x120 8 slots Heavy	33	255.3	16.5	42.6	5.2	1.11.40.040120.08H
Strut Profile PG40 40x160 10 slots	31.6	435.7	15.8	54.5	4.8	1.11.40.040160.10
Strut Profile PG40 40x160 10 slots Heavy	43.7	582.2	21.8	72.8	6.8	1.11.40.040160.10H
<b>Strut Profile PG40 80x80 8 slots</b>	109.9	109.9	27.5	27.5	4.2	<b>1.11.40.080080.08</b>





80x80 8 slots Heavy



80x80 R90 6 slots

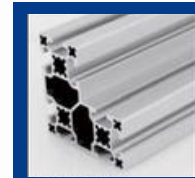

80x80 L 8 slots

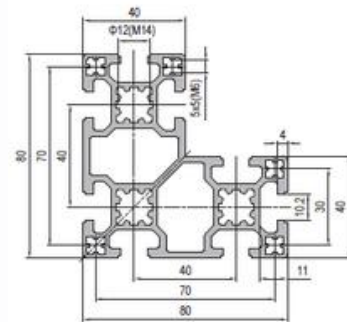
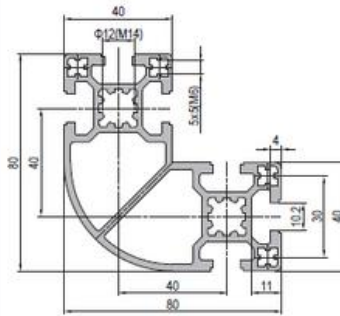
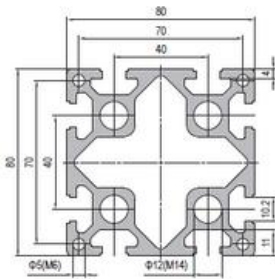

80x120 10 slots

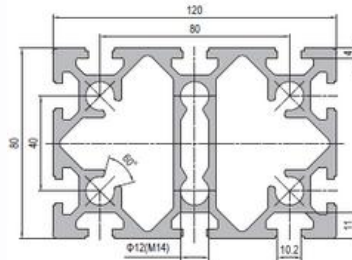

Description	Moment of Inertia $I_x(\text{cm}^4)$	Moment of Inertia $I_y(\text{cm}^4)$	Moment of Resistance $W_x(\text{cm}^3)$	Moment of Resistance $W_y(\text{cm}^3)$	Mass (Kg/m)	Part No.
<b>Strut Profile PG40 80x80 8 slots Heavy</b>	148.2	148.2	37.1	37.1	5.7	<b>1.11.40.080080.08H</b>
Strut Profile PG40 80x80 R90 6 slots	73	73	20	20	3.4	1.11.40.080080.R90.06
Strut Profile PG40 80x80 L 8 slots	83.9	83.9	24.7	24.7	4	1.11.40.080080L.08
Strut Profile PG40 80x120 10 slots	222.1	449.2	55.5	74.8	8.3	1.11.40.080120.10

Más vendido

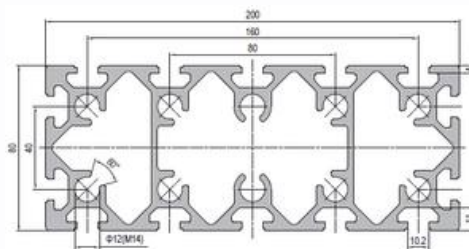
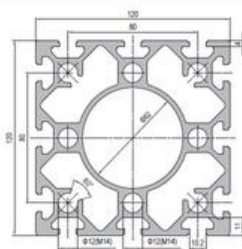
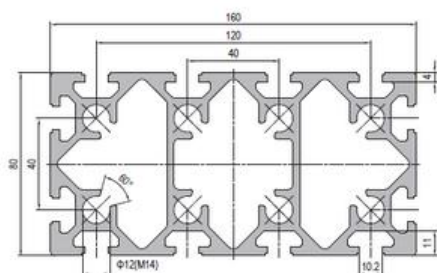

Description	Moment of Inertia $I_x(\text{cm}^4)$	Moment of Inertia $I_y(\text{cm}^4)$	Moment of Resistance $W_x(\text{cm}^3)$	Moment of Resistance $W_y(\text{cm}^3)$	Mass (Kg/m)	Part No.
<b>Strut Profile PG40 80x160 12 slots</b>	287.5	975.5	71.9	121.9	10.4	<b>1.11.40.080160.12</b>
Strut Profile PG40 80x200 14 slots	353.1	1789.8	88.3	179	12.3	1.11.40.080200.14
Strut Profile PG40 120x120 12 slots	659.1	659.1	109.9	109.9	11.5	1.11.40.120120.12



### Elementos de Conexión Compatibles

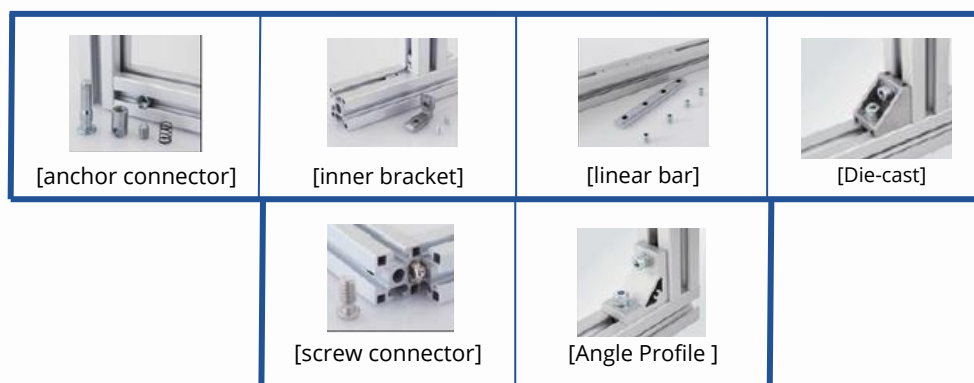

# PERFIL DE ALUMINIO PG45-PG50-PG60

## Strut Profile



**Material:** 6063-T6  
**Surface:** Anodized 11µM  
**Color:** Silver / Plateado

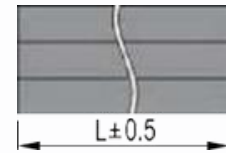

**Effective length:** 5800mm  
 Cut section not anodized.

Perfil estructural PG45-50-60 con T-slot de 10.2mm está diseñado para construcciones de gran peso (Marcos de maquinaria, paredes separadoras, etc.)

Strut profile PG45-50-60, with 10.2mm T-slot, is designed for medium weight structures and heavy loading structures, such as machine frame, factory partition, etc.

T Slot Symbol Símbolo de ranura	Cross Section Sección cruzada	Core Hole Agujero de centro	Slot Width Ancho de ranura	Slot Depth Profundidad de ranura	Wall Thickness Ancho de Paredes	Profile Group Grupo de perfil
		12.0	10.2	13.0	6.0	PG45 PG50 PG55

PG15-PG20

PG30

PG40

PG45- PG50  
PG60

**PG45x45**



45x45 R45 2 slots



45x45 R90 2 slots



45x45 2 slots Type A



45x45 2 slots Type B

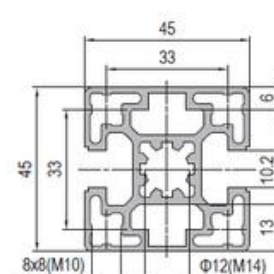
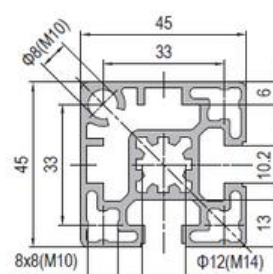
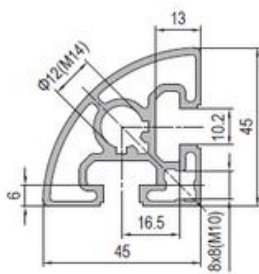
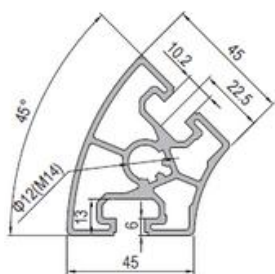

45x45 3 slots



45x45 4 slots Light



45x45 4 slots



45x45 4 slots Heavy

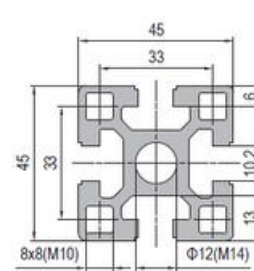
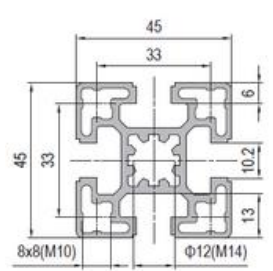
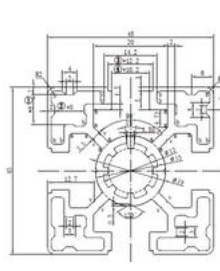
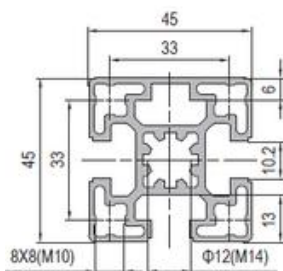





45x90 6 slots Heavy



45x180 10 slots

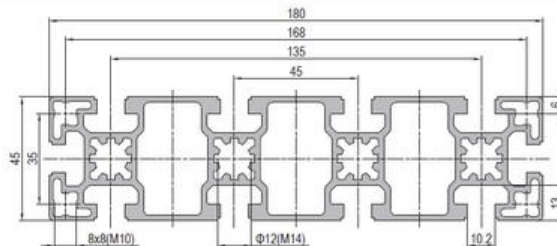
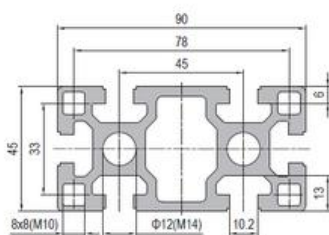

Description	Moment of Inertia $I_x(\text{cm}^4)$	Moment of Inertia $I_y(\text{cm}^4)$	Moment of Resistance $W_x(\text{cm}^3)$	Moment of Resistance $W_y(\text{cm}^3)$	Mass (Kg/m)	Part No.
Strut Profile PG45 45x60 4 slots	16.2	27.8	7.2	9.3	2.4	1.11.45.045060.04
Strut Profile PG45 45x90 6 slots Light	21.6	80	9.6	17.7	2.85	1.11.45.045090.06L
<b>ALUMINUM PROFILE 45MM X 90MM, 3.128/M14 A.PLATED</b>	24.1	89.3	10.8	19.9	3.2	<b>ADV 45X90-3.128/M14</b>
Strut Profile PG45 45x90 6 slots Heavy	32.5	122.2	14.5	27.2	4.4	1.11.45.045090.06H
Strut Profile PG45 45x180 10 slots	48.4	640.6	21.5	71.2	5.8	1.11.45.045180.10



90x90 8 slots



90x90 8 slots Heavy

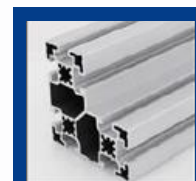



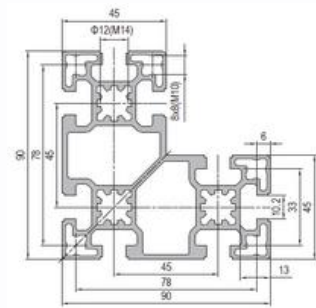
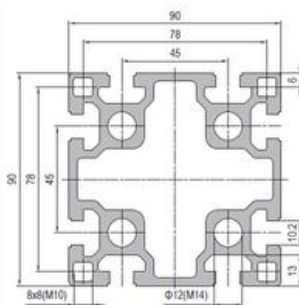
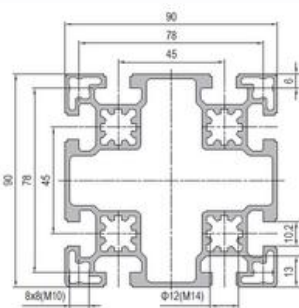

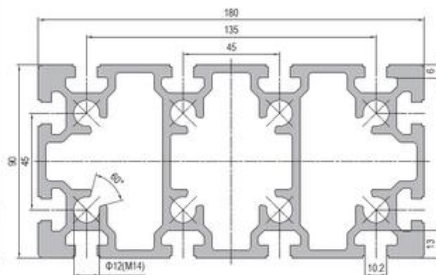

90x90 L 8 slots





Description	Moment of Inertia $I_x(\text{cm}^4)$	Moment of Inertia $I_y(\text{cm}^4)$	Moment of Resistance $W_x(\text{cm}^3)$	Moment of Resistance $W_y(\text{cm}^3)$	Mass (Kg/m)	Part No.
Strut Profile PG45 90x90 8 slots	163.2	163.2	36.3	36.3	5	1.11.45.090090.08
Strut Profile PG45 90x90 8 slots Light	222.9	222.9	49.6	49.6	6.8	1.11.45.090090.08H
Strut Profile PG45 90x90 L 8 slots	121.5	121.5	32	32	4.6	1.11.45.090090L.08
Strut Profile PG45 90x180 12 slots	454.9	1585.7	101.1	176.2	12.7	1.11.45.090180.12

### Elementos de Conexión Compatibles

 [anchor connector]	 [inner bracket]	 [linear bar]	 [Die-cast]
 [screw connector]		 [Angle Profile ]	

**PG50x50**



50x50 4 slots Light



50x50 4 slots



50x100 6 slots

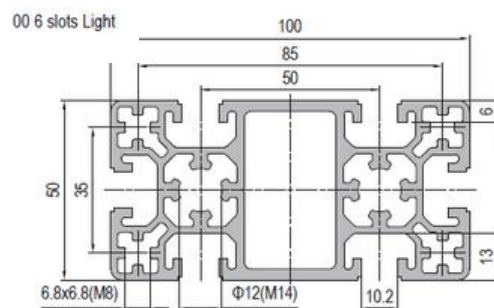
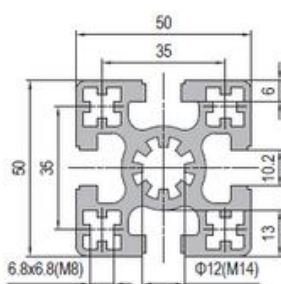
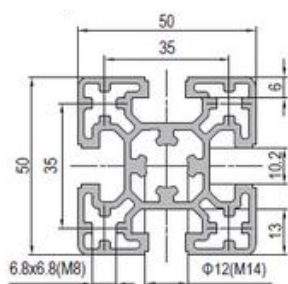

50x100 6 slots



100x100 8 slots

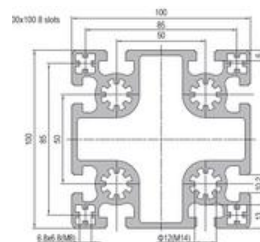
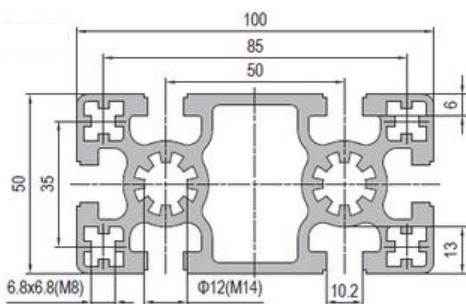

Description	Moment of Inertia $I_x(\text{cm}^4)$	Moment of Inertia $I_y(\text{cm}^4)$	Moment of Resistance $W_x(\text{cm}^3)$	Moment of Resistance $W_y(\text{cm}^3)$	Mass (Kg/m)	Part No.
Strut Profile PG50 50x50 4 slots Light	20.19	20.19	8.16	8.16	2.35	1.11.50.050050.04L
Strut Profile PG50 50x50 4 slots	25	25	10	10	3	1.11.50.050050.04
Strut Profile PG50 50x100 6 slots Light	41.3	156.7	16.5	31.3	4.2	1.11.50.050100.06L
Strut Profile PG50 50x100 6 slots	56.2	184.4	18.5	36.9	5	1.11.50.050100.06
Strut Profile PG50 100x100 8 slots	331.1	331.1	66.2	66.2	8.5	1.11.50.100100.08

### Elementos de Conexión Compatibles



**PG60x60**

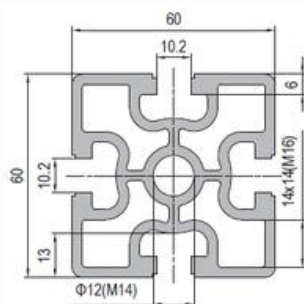

Description	Moment of Inertia $I_x(\text{cm}^4)$	Moment of Inertia $I_y(\text{cm}^4)$	Moment of Resistance $W_x(\text{cm}^3)$	Moment of Resistance $W_y(\text{cm}^3)$	Mass (Kg/m)	Part No.
Strut Profile PG60 60x60 4 slots	47.7	47.7	15.9	15.9	3.8	1.11.60.060060.04

**Elementos de Conexión Compatibles**



# TORNILLERÍA Y HERRAJE



Pre-set Nut  
Square Nut  
T-Nut  
Subsequent Nut  
Anti-torsion Subsequent Nut  
T-Bolt  
Hole Reducer Bolt

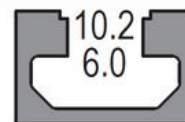
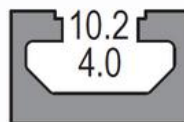

# Pre-set Nut

## Tornillería y Herraje



**Material:** Pre-set Nut-nickel plated steel  
Pre-set Nut Sleeve- EVA

La tuerca plana es colocada en la ranura desde el final del perfil. Con poca eficiencia de ensamble, pero buena conexión y asegurando estabilidad. La cejilla evita que se deslice durante el ensamble y puede arreglarse desde cualquier posición requerida, en especial verticalmente.

Pre-set Nut can be only put into T slot from profile end, with low assembly efficiency, but with good connection and stability. The sleeve is to avoid any sliding when using the pre-set nut for assembly and can be fixed at any required position, especially in vertical position.

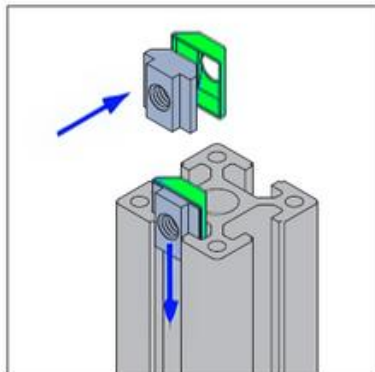

**Confiabilidad**



**Eficiencia**



**Económico**

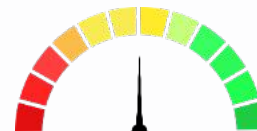



**Pre-set Nut-6-M4**  
**Pre-set Nut-6-M5**

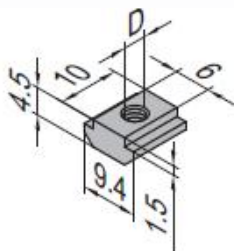

Description	D	Mass (g/pcs)	Part No.
Pre-set Nut-6-M4	M4	3	2.11.06.M4
Pre-set Nut-6-M5	M5	3	2.11.06.M5

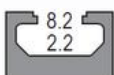

**Pre-set Nut-8-M4**  
**Pre-set Nut-8-M5**  
**Pre-set Nut-8-M6**  
**Pre-set Nut Sleeve-8**

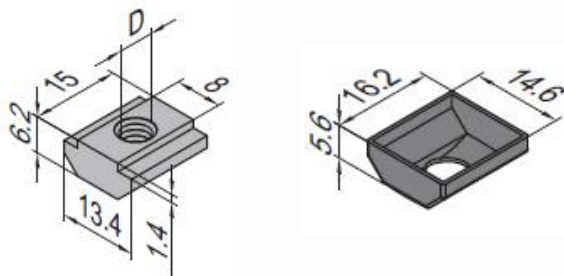

Description	D	Mass (g/pcs)	Part No.
Pre-set Nut-8-M4	M4	8	2.11.08.M4
Pre-set Nut-8-M5	M5	8	2.11.08.M5
Pre-set Nut-8-M6	M6	7	2.11.08.M6
Pre-set Nut Sleeve-8		0.3	2.11.08.01

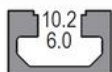

**Pre-set Nut-10-M4**  
**Pre-set Nut-10-M5**  
**Pre-set Nut-10-M6**  
**Pre-set Nut-10-M8**  
**Pre-set Nut Sleeve-10**

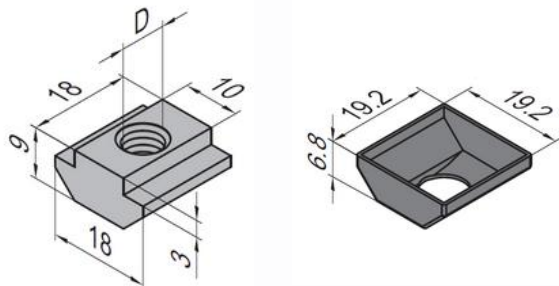

Description	D	Mass (g/pcs)	Part No.
Pre-set Nut-10-M4	M4	16	2.11.10.M4
Pre-set Nut-10-M5	M5	16	2.11.10.M5
Pre-set Nut-10-M6	M6	15	2.11.10.M6
Pre-set Nut-10-M8	M8	14	2.11.10.M8
Pre-set Nut Sleeve-10		0.4	2.11.10.01

# Square Nut

## Tornillería y Herraje



**Material:** Zinc plated steel

El clip incluido evita que se deslice al usar la tuerca cuadrada (Square Nut) para ensambles, y puede arreglarse y modificarse desde cualquier posición, en especial verticalmente

This clip is to avoid any sliding when using the square nut for assembly and can be fixed at any required position, especially at vertical position

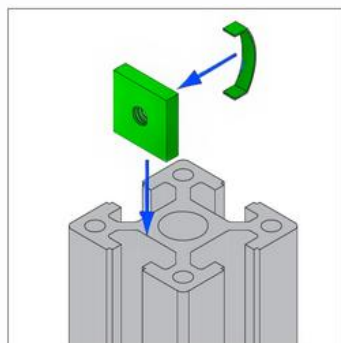

**Confiabilidad**

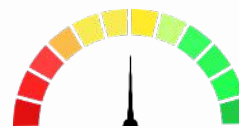

**Eficiencia**



**Económico**





**Square Nut-8-M4**  
**Square Nut-8-M5**  
**Square Nut-8-M6**  
**Square Nut Clip-8**

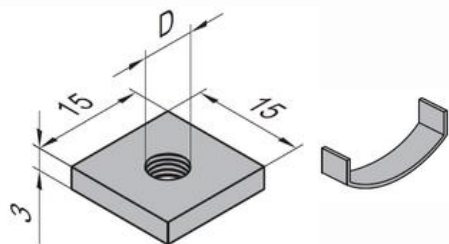

Description	D	Mass (g/pcs)	Part No.
Square Nut-8-M4	M4	5	2.12.08.M4
Square Nut-8-M5	M5	5	2.12.08.M5
Square Nut-8-M6	M6	5	2.12.08.M6
Square Nut Clip-8		0.4	2.12.08.01

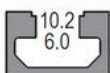
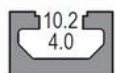

**Square Nut-10-M4**  
**Square Nut-10-M5**  
**Square Nut-10-M6**  
**Square Nut-10-M8**  
**Square Nut Clip-10**

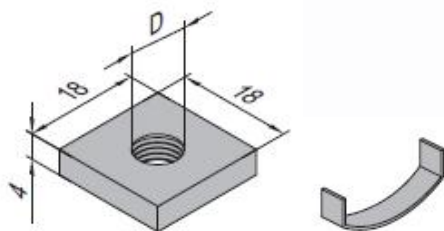

Description	D	Mass (g/pcs)	Part No.
Square Nut-10-M4	M4	10	2.12.10.M4
Square Nut-10-M5	M5	10	2.12.10.M5
Square Nut-10-M6	M6	9	2.12.10.M6
Square Nut-10-M8	M8	8	2.12.10.M8
Square Nut Clip-10		0.5	2.12.10.01

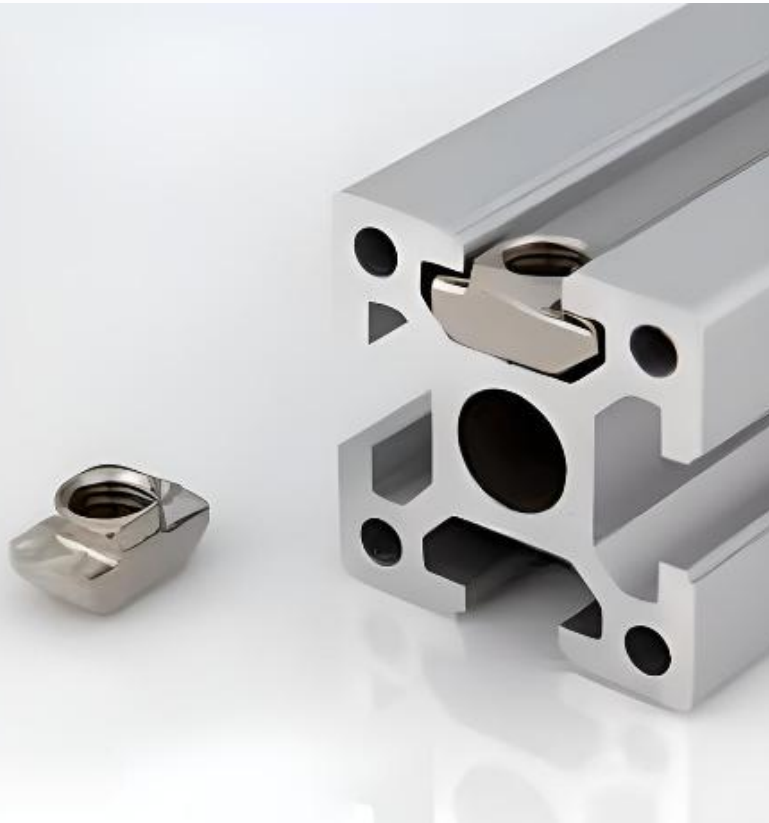

**Material:** Nickel plated steel

La tuerca T (o tuerca martillo) se inserta directamente en el punto de ensamble, haciendo el armado eficiente. Sin embargo la fuerza de conexión y estabilidad no es tan buena como las de la Tuerca plana.

T Nut can be inserted directly at the assembly point, which makes the assembly very efficient, however the connection strength and stability is not as good as the Pre-set Nut

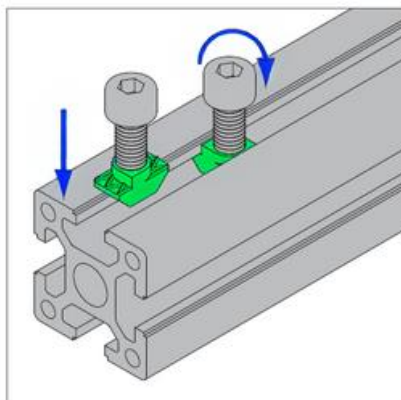

**Confiabilidad**



**Eficiencia**



**Económico**





**T Nut-6-M4**  
**T Nut-6-M5**

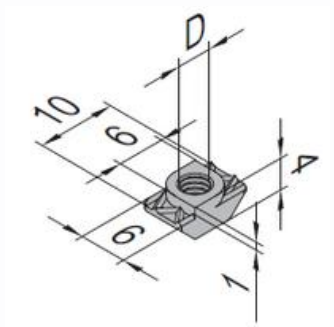

Description	D	Mass (g/pcs)	Part No.
T Nut-6-M4	M4	2	2.21.06.M4
T Nut-6-M5	M5	2	2.21.06.M5

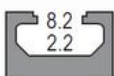

**T Nut-8-M4**  
**T Nut-8-M5**  
**T Nut-8-M6**

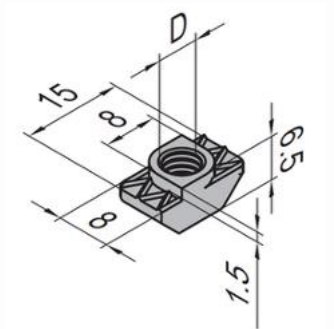

Description	D	Mass (g/pcs)	Part No.
T Nut-8-M4	M4	4	2.21.08.M4
T Nut-8-M5	M5	4	2.21.08.M5
<b>T Nut-8-M6</b>	M6	3	<b>2.21.08.M6</b>



**T Nut-10-M4**  
**T Nut-10-M5**  
**T Nut-10-M6**  
**T Nut-10-M8**

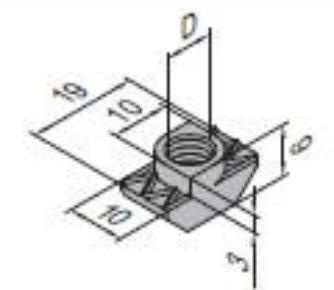

Description	D	Mass (g/pcs)	Part No.
<b>T Nut-10-M4</b>	M4	8	<b>2.21.10.M4</b>
<b>T Nut-10-M5</b>	M5	8	<b>2.21.10.M5</b>
<b>T Nut-10-M6</b>	M6	7	<b>2.21.10.M6</b>
<b>T Nut-10-M8</b>	M8	6	<b>2.21.10.M8</b>



# Subsequent Nut

## Tornillería y Herraje



**Material:** Zinc plated steel

La Tuerca de presión con cejilla se inserta directamente en el punto de ensamble. La cejilla ayuda al armado y el posicionamiento. La fuerza de conexión y estabilidad es la misma que la Tuerca T.

Subsequent Nut with a spring leaf can be inserted directly at the assembly point. The spring assists with assembly and positioning. The connecting strength and stability is same as T-Nut

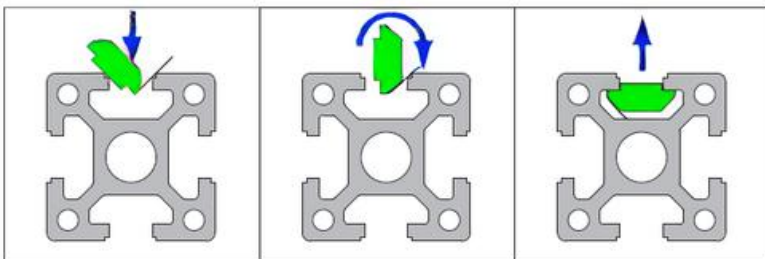

**Confiabilidad**



**Eficiencia**



**Económico**



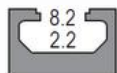

**Subsequent Nut-8-M4**  
**Subsequent Nut-8-M5**  
**Subsequent Nut-8-M6**

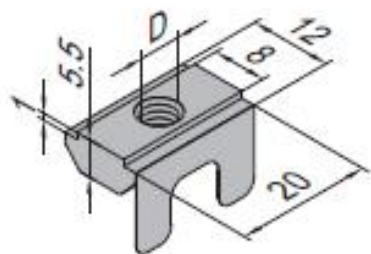

Description	D	Mass (g/pcs)	Part No.
Subsequent Nut-8-M4	M4	8	2.31.08.M4
Subsequent Nut-8-M5	M5	8	2.31.08.M5
Subsequent Nut-8-M6	M6	7	2.31.08.M6
Subsequent Nut-8-M8	M8	7	2.31.08.M8

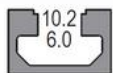

**Subsequent Nut-10-M4**  
**Subsequent Nut-10-M5**  
**Subsequent Nut-10-M6**

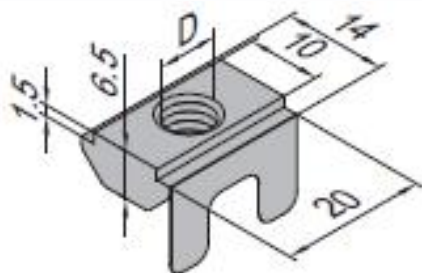

Description	D	Mass (g/pcs)	Part No.
Subsequent Nut-10-M4	M4	10	2.31.10.M4
Subsequent Nut-10-M5	M5	10	2.31.10.M5
Subsequent Nut-10-M6	M6	9	2.31.10.M6
Subsequent Nut-10-M8	M8	9	2.31.10.M8

# Anti-torsion Subsequent-Nut

Tornillería y Herraje



**Material:** Nickel plated steel

Previene a los perfiles con Screw connectors de torsión.

Prevent profiles with screw connectors from torsion.

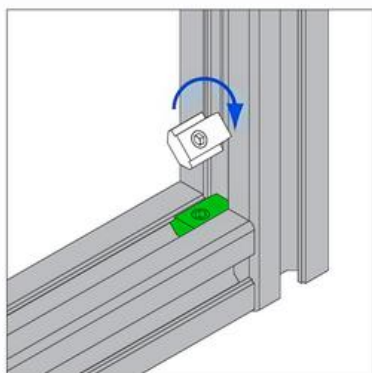

**Confiabilidad**



**Eficiencia**



**Económico**

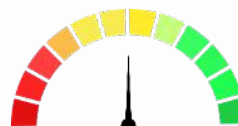

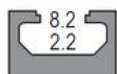

### Anti-torsion Subsequent Nut-8

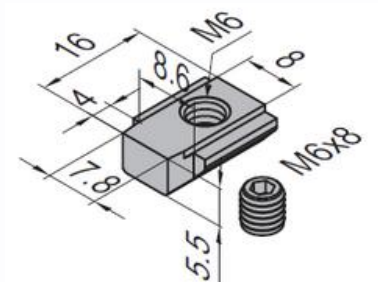

Description	Mass (g/pcs)	Part No.
Anti-torsion Subsequent Nut-8 (with top thread)	10	2.32.08.M6

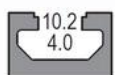

### Anti-torsion Subsequent Nut-10

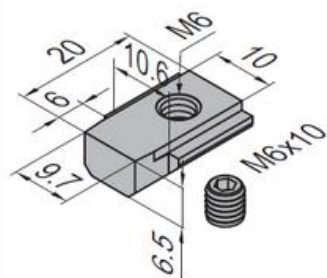

Description	Mass (g/pcs)	Part No.
Anti-torsion Subsequent Nut-10 (with top thread)	15	2.32.10.M6

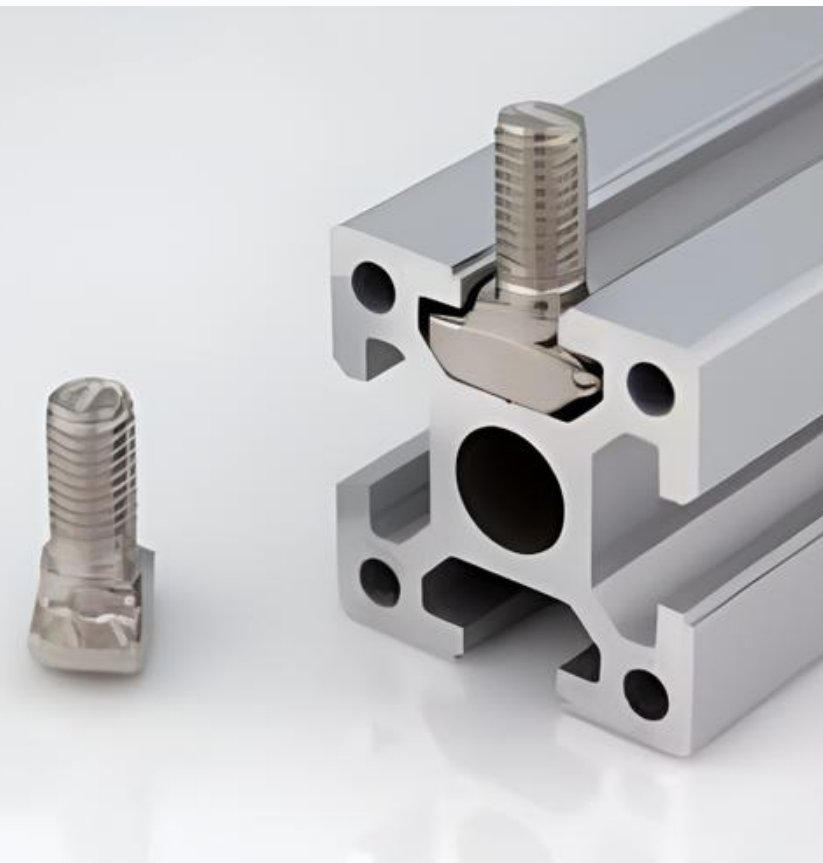

**Material:** Nickel plated steel

Similar a la tuerca T. El tornillo cabeza de martillo puede ser insertado directamente en el punto de ensamble con alta eficiencia. La fuerza de conexión y estabilidad es igual al de la tuerca T.

Similar to T nut. T bolt can be inserted directly at the assembly point with high assembly efficiency. The connection strength and stability are same as T nut.

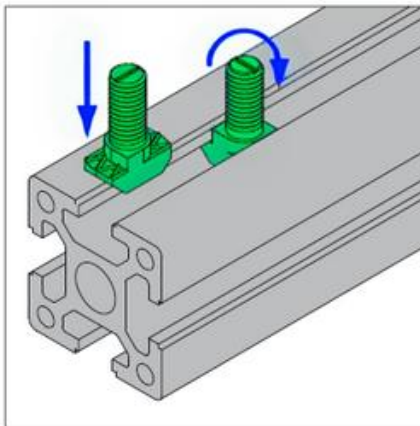



**T Bolt-8-16**  
**T Bolt-8-20**  
**T Bolt-8-25**

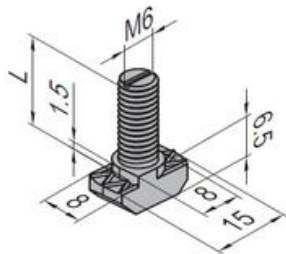

Description	L (mm)	Mass (g/pcs)	Part No.
T Bolt-8-16	16	7	2.41.08.16
<b>T Bolt-8-20</b>	20	8	<b>2.41.08.20</b>
T Bolt-8-25	25	9	2.41.08.25

Más vendido



**T Bolt-10-20**  
**T Bolt-10-25**  
**T Bolt-10-30**  
**T Bolt-10-35**

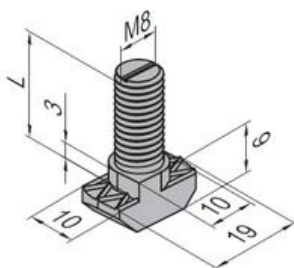

Description	L (mm)	Mass (g/pcs)	Part No.
<b>T Bolt-10-20</b>	20	13	<b>2.41.10.20</b>
<b>T Bolt-10-25</b>	25	15	<b>2.41.10.25</b>
T Bolt-10-30	30	17	2.41.10.30
T Bolt-10-35	35	19	2.41.10.35

Más vendido

Más vendido



**Material:** Nickel plated steel

Reduce el diámetro del hueco del perfil para mejorar la fuerza de conexión

---

To reduce the hole diameter of the profile and improve the connection strength

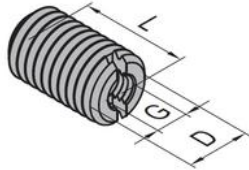

Description	D	G	L (mm)	Mass (g/pcs)	Part No.
Hole Reducer Bolt-M10/M6	M10	M6	15	8	2.51.10.06
Hole Reducer Bolt-M12/M6	M12	M6	20	11	2.51.12.06
Hole Reducer Bolt-M14/M8	M14	M8	20	14	2.51.14.08
Hole Reducer Bolt-M14/M10	M14	M10	20	8	2.51.14.10
Hole Reducer Bolt-M16/M8	M16	M8	20	19	2.51.16.08



# ELEMENTOS DE UNIÓN











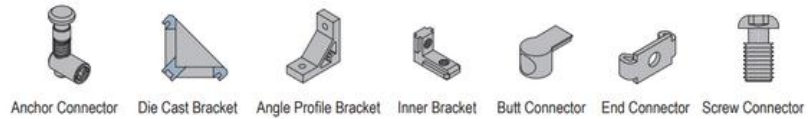









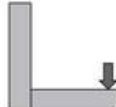















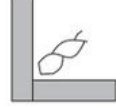























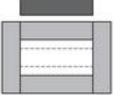







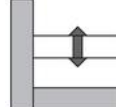







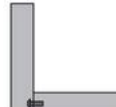





Anchor Connector  
Die Cast Bracket  
Angle Profile Bracket  
Inner Bracket  
Linear Bar Bracket  
Joining Plate  
Butt Connector  
End Connector  
Screw Connector  
Cubic Connector

# COMPARATIVE CHART FOR SELECTION

## TABLA COMPARATIVA PARA SELECCIÓN

-  Recommended
-  Suitable
-  Unsuitable



	Anchor Connector	Die Cast Bracket	Angle Profile Bracket	Inner Bracket	Butt Connector	End Connector	Screw Connector
 High feed force							
 High moment							
 High torsional moment							
 Minimal finishing work							
 Minimal assembly							
 Low parts costs							
 Subsequent mounting in closed frame							
 Adjustment possible							
 Internal connection (concealable)							
 Angle Connection							

# Anchor Connector

Elementos de unión

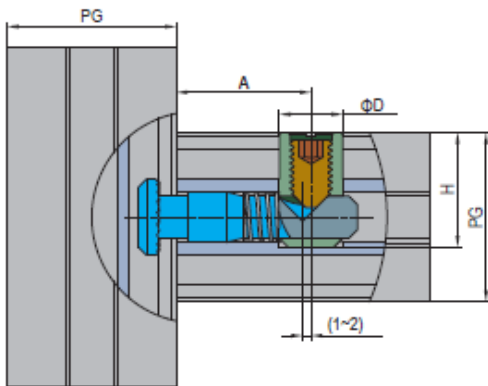

**Material:** Nickel plated steel

Previene a los perfiles con screw connectors de torsión. Añade alta fuerza y fácil ajuste. Solo una ranura es usada para la conexión.

Prevent profiles with screw connectors from torsion. It adds high strength and easily adjust. Only one slot it's used for connection

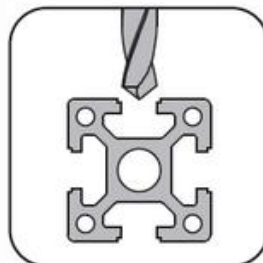
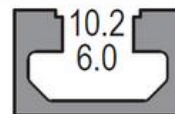
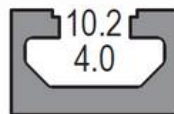
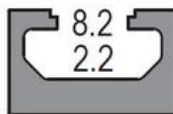

## Universal

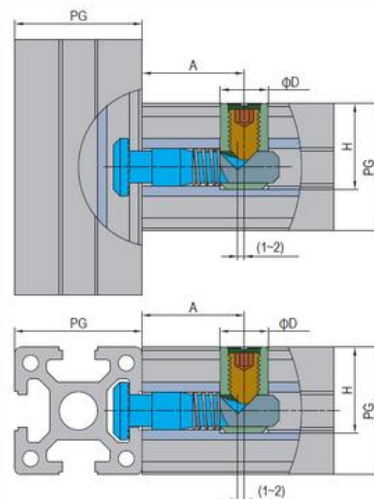
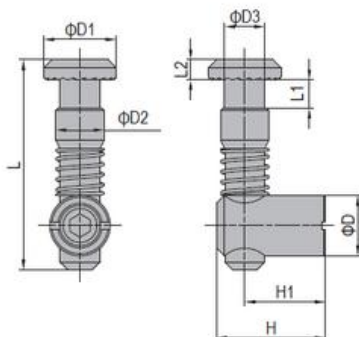
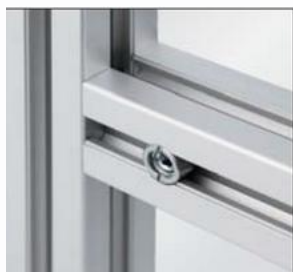

Description	A	D	H	H1	L1	L2	D1	D2	D3	L	Mass	Part No.
PG30-Universal	30	12	21	15	7	4	14	9.9	8	45	38	3.11.30.01
PG40-Universal	32	15	27	20	7	5	18	11.9	10	52	58	3.11.40.01
PG45-Universal	30	15	29.5	22.5	7	5	18	11.9	10	52	60	3.11.45.01

## Standard Model P

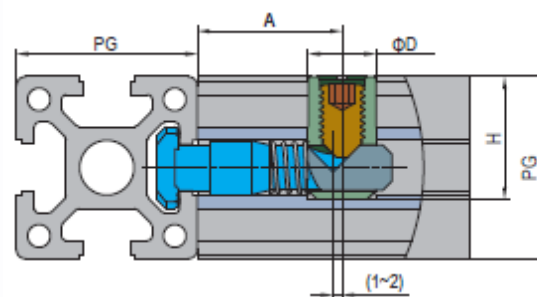
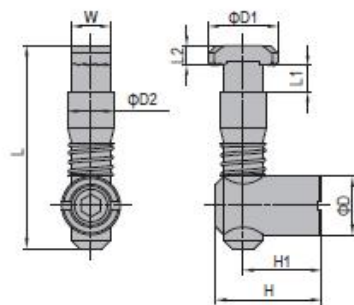
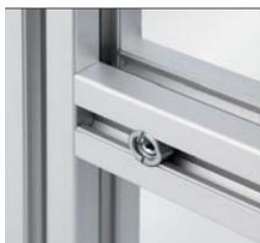

Description	A	D	H	H1	L1	L2	D1	D2	W	L	Mass	Part No.
PG30-Standard (Model P)	30	12	21	15	7	4	14	9.9	8	45	38	3.11.30.02
PG40-Standard (Model P)	32	15	27	20	7	5	18	11.9	10	52	58	3.11.40.02
<b>PG45-Standard (Model P)</b>	30	15	29.5	22.5	7	5	18	11.9	10	52	60	<b>3.11.45.02</b>



## Standard Model C

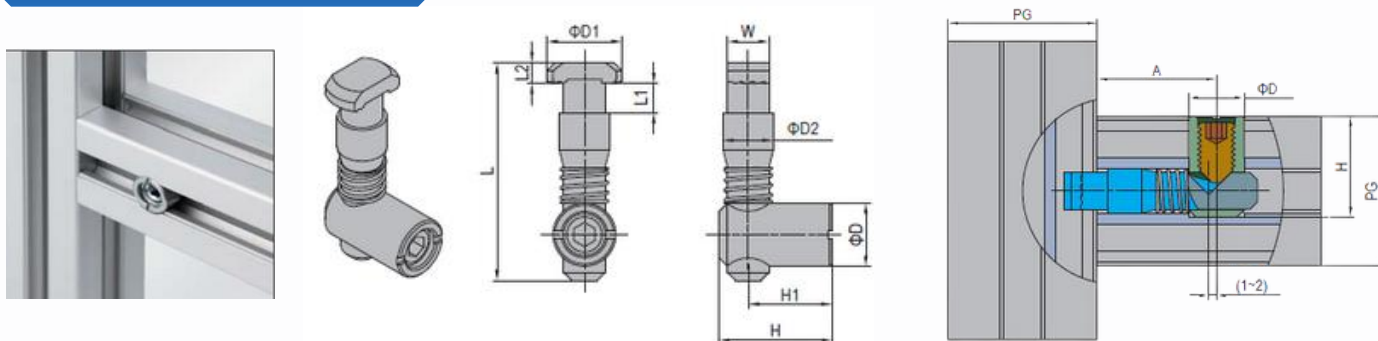

Description	A	D	H	H1	L1	L2	D1	D2	W	L	Mass	Part No.
PG30-Standard (Model C)	30	12	21	15	7	4	14	9.9	8	45	38	3.11.30.03
PG40-Standard (Model C)	32	15	27	20	7	5	18	11.9	10	52	58	3.11.40.03
PG45-Standard (Model C)	30	15	29.5	22.5	7	5	18	11.9	10	52	60	3.11.45.03

## Oblique Model P

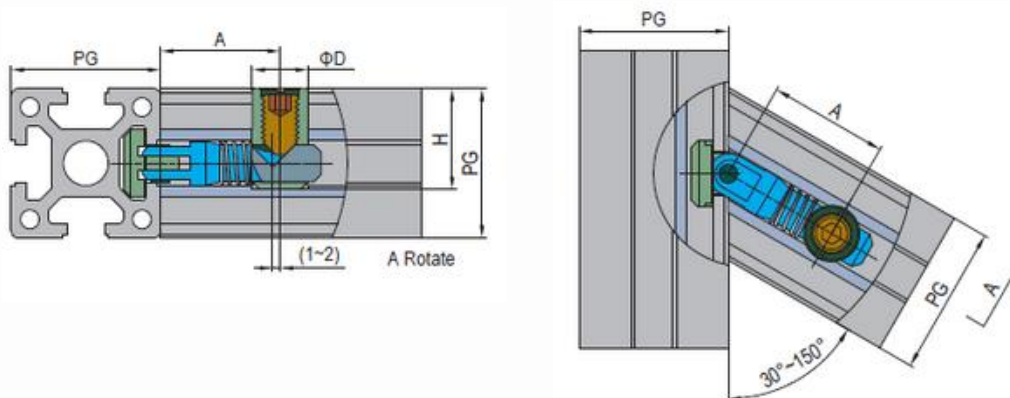
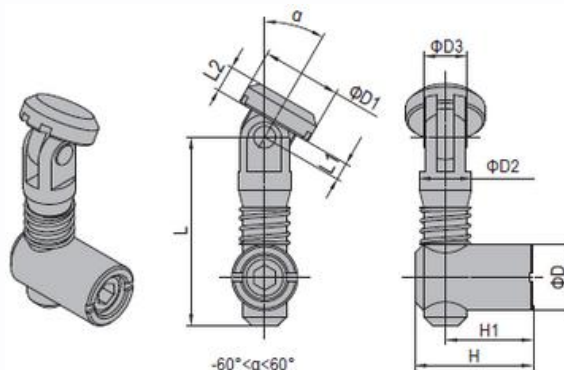

Description	A	D	H	H1	L1	L2	D1	D2	D3	L	Mass	Part No.
PG30-Oblique (Model P)	30	12	21	15	2.2	5	14	9.9	8	38.8	55	3.11.30.04
PG40-Oblique (Model P)	32	15	27	20	4	6	18	11.9	10	43	72	3.11.40.04
<b>PG45-Oblique (Model P)</b>	30	15	29.5	22.5	6	5	18	11.9	10	43	78	<b>3.11.45.04</b>



## Oblique Model C

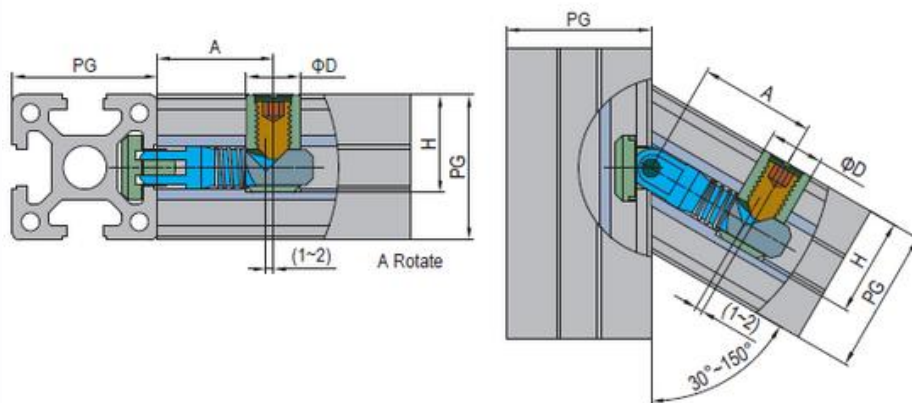
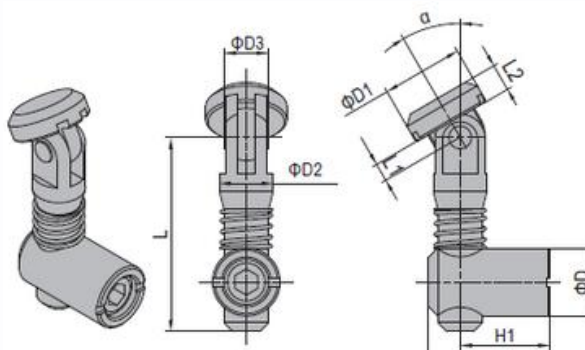

Description	A	D	H	H1	L1	L2	D1	D2	D3	L	Mass	Part No.
PG30-Oblique (Model C)	30	12	21	15	2.2	5	14	9.9	8	38.8	55	3.11.30.05
PG40-Oblique (Model C)	32	15	27	20	4	6	18	11.9	10	43	72	3.11.40.05
PG45-Oblique (Model C)	30	15	29.5	22.5	6	5	18	11.9	10	43	78	3.11.45.05

## Miter Model P

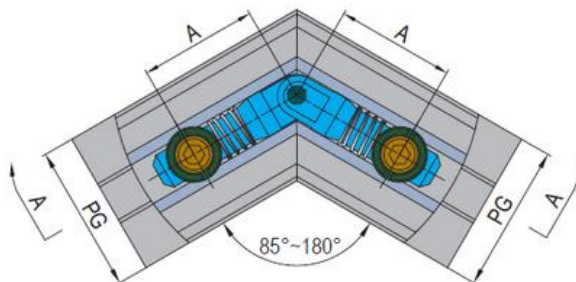
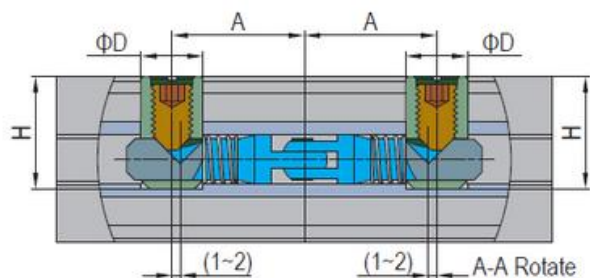
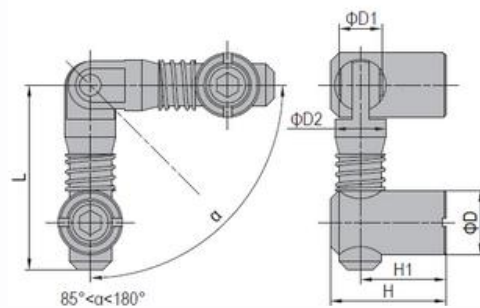
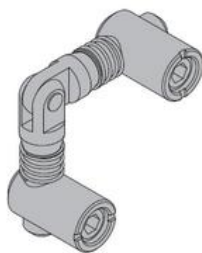

Description	A	D	H	H1	D1	D2	L	Mass	Part No.
PG30-Miter (Model P)	30	12	21	15	8	9.9	38.8	63	3.11.30.06
PG40-Miter (Model P)	32	15	27	20	10	11.9	43	97	3.11.40.06
PG45-Miter (Model P)	30	15	29.5	22.5	10	11.9	43	100	3.11.45.06

# Die Cast Bracket

Elementos de unión



**Material:** Die cast aluminium

Aporta alta fuerza, es de fácil ajuste y utiliza únicamente una ranura para la conexión.



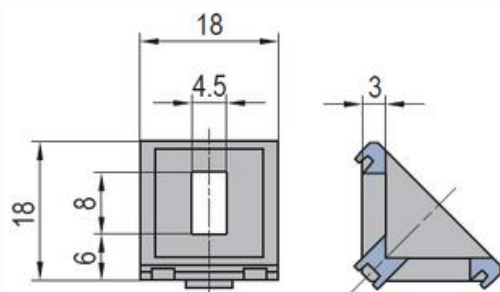

---

High strength, easily adjust, only 1 slot used for connection

## PG20 20x20







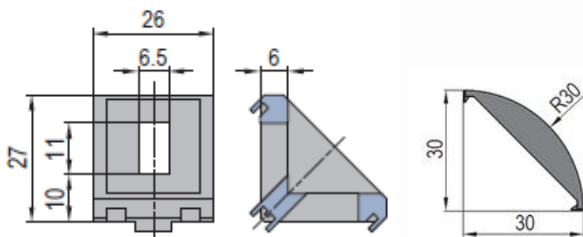
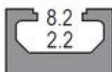

Description	Fastening Set	Mass (g)	Part No.
PG20-20x20 (pcs)		5	3.21.20.2020
PG20-20x20 (set M)	2x <b>M</b>	12	3.21.20.2020.SETM
PG20-20x20 (set Z)	2x <b>Z</b>	12	3.21.20.2020.SETZ

<b>M</b>	Fastening Set	<b>Z</b>	Fastening Set
	M4x8 Bolt		M4x8 Bolt
	M4 T Nut		M4 Pre-set Nut

## PG30 30x30



Description	Fastening Set	Mass (g)	Part No.
PG30-30x30 (pcs)		21	3.21.30.3030
<b>PG30-30x30 (set A)</b>	2x <b>A</b>	42	<b>3.21.30.3030.SETA</b>
PG30-30x30 (set B)	2x <b>B</b>	48	3.21.30.3030.SETB
Bracket Cap PG30-30x30		3	3.22.30.3030
PG30-30x60 (pcs)		53	3.21.30.3060
<b>PG30-30x60 (set A)</b>	4x <b>A</b>	93	<b>30.2.02.030060.02.SETA</b>
PG30-30x60 (set B)	4x <b>B</b>	105	3.21.30.3060.SETB
Bracket Cap PG30-30x60		12.4	3.22.30.3060
PG30-60x60 (pcs)		120	3.21.30.6060
PG30-60x60 (set A)	8x <b>A</b>	200	3.21.30.6060.SETA
PG30-60x60 (set B)	8x <b>B</b>	224	3.21.30.6060.SETB
Bracket Cap PG30-60x60		13.9	3.22.30.6060

<b>A</b>	Fastening Set	<b>B</b>	Fastening Set
	M6x14 Bolt		M6x14 Bolt
	M6 Washer		M6 Washer
	M6 T Nut		M6 Pre-set Nut

## PG30 30x60

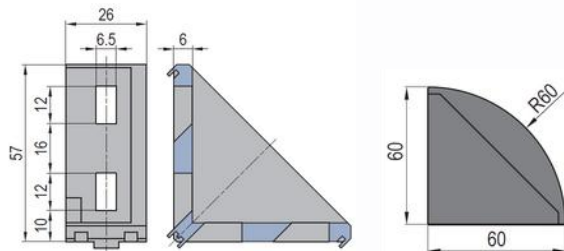

## PG30 60x60

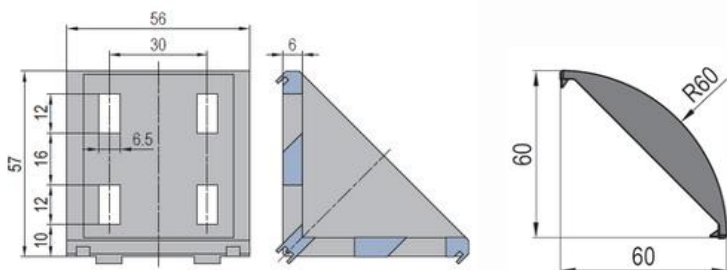

## PG40 40x40

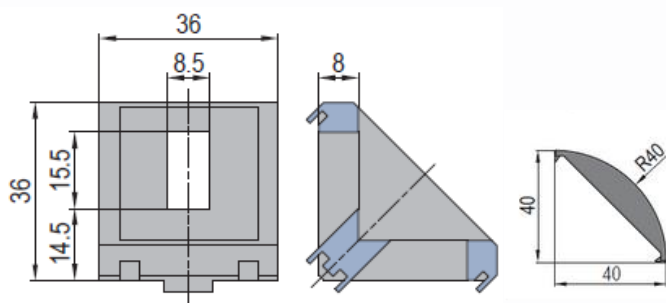
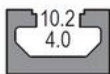

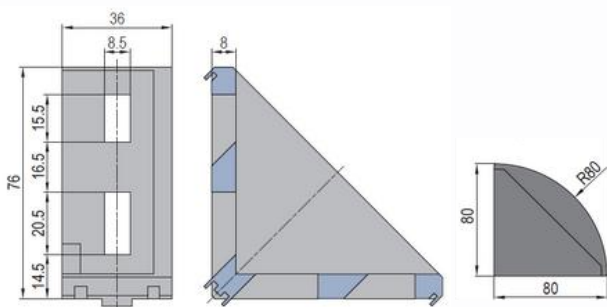

## PG40 40x80

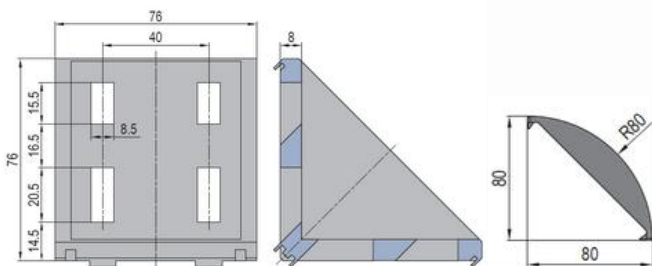

# PG40 80x80



Description	Fastening Set	Mass (g)	Part No.
PG40-40x40 (pcs)		50	3.21.40.4040
<b>PG40-40x40 (set C)</b>	<b>2xC</b>	92	<b>3.21.40.4040.SETC</b> 
PG40-40x40 (set D)	<b>2xD</b>	92	3.21.40.4040.SETD
PG40-40x40 (set E)	<b>2xE</b>	106	3.21.40.4040.SETE
Bracket Cap PG40-4040		6	3.22.40.4040
PG40- 40x80 (pcs)		125	3.21.40.4080
<b>PG40-40x80 (set C)</b>	<b>4xC</b>	210	<b>3.21.40.4080.SETC</b> 
PG40-40x80 (set F)	<b>4xF</b>	220	3.21.40.4080.SETF
PG40-40x80 (set G)	<b>4xG</b>	250	3.21.40.4080.SETG
Bracket Cap PG40-40x80		22.6	3.22.40.4080
PG40-80x80 (pcs)		260	3.21.40.8080
<b>PG40-80x80 (set C)</b>	<b>8xC</b>	428	<b>3.21.40.8080.SETC</b> 
PG40-80x80 (set F)	<b>8xF</b>	452	3.21.40.8080.SETF
PG40-80x80 (set G)	<b>8xG</b>	508	3.21.40.8080.SETG
Bracket Cap PG40-8080		25.6	3.22.40.8080

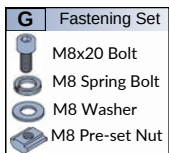
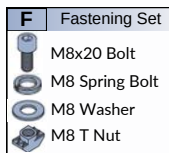
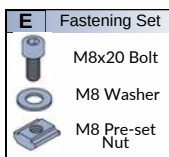
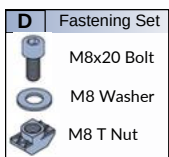
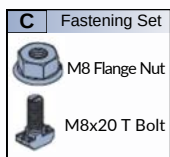

## PG45 45x45

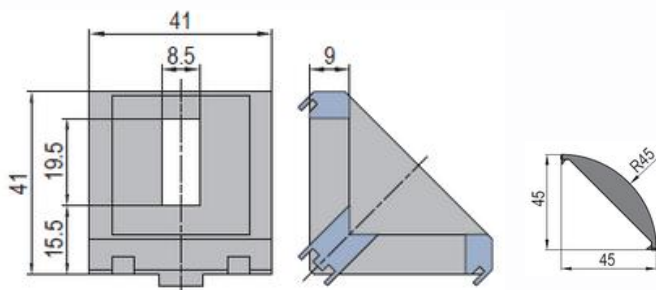
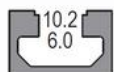



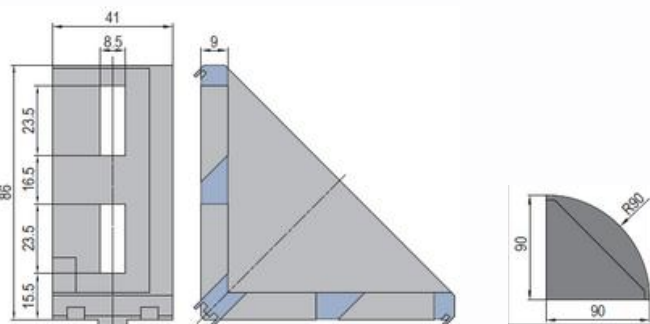



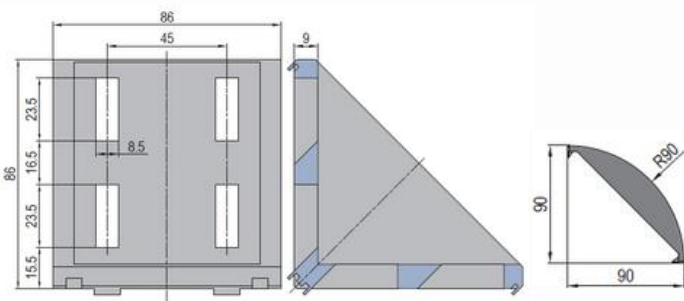



## PG45 45x90



## PG40 80x80



Description	Fastening Set	Mass (g)	Part No.
PG45-45x45 (pcs)		72	3.21.45.4545
<b>PG45-45x45 (set H)</b>	2x <b>H</b>	118	<b>3.21.45.4545.SETH</b>
PG45-45x45 (set J)	2x <b>J</b>	122	3.21.45.4545.SETJ
PG45-45x45 (set K)	2x <b>K</b>	134	3.21.45.4545.SETK
Bracket Cap PG45-4545		7.6	3.22.45.4545
PG45- 45x90 (pcs)		190	3.21.45.4590
<b>PG45-45x90 (set H)</b>	4x <b>H</b>	282	<b>3.21.45.4590.SETH</b>
PG45-45x90 (set J)	4x <b>J</b>	290	3.21.45.4590.SETJ
PG45-45x90 (set K)	4x <b>K</b>	314	3.21.45.4590.SETK
Bracket Cap PG45-4590		28.7	3.22.45.4590
PG45-90x90 (pcs)		390	3.21.45.9090
<b>PG45-90x90 (set H)</b>	8x <b>H</b>	574	<b>3.21.45.9090.SETH</b>
PG45-90x90 (set J)	8x <b>J</b>	590	3.21.45.9090.SETJ
PG45-90x90 (set K)	8x <b>K</b>	638	3.21.45.9090.SETK
Bracket Cap PG45-9090		32.5	3.22.45.9090

H	Fastening Set	J	Fastening Set	K	Fastening Set
	M8 Flange Nut		M8x25 Bolt		M8x25 Bolt
	M8x25 T Bolt		M8 Spring Washer		M8 Spring Washer
			M8 Washer		M8 Washer
			M8 T Nut		M8 Pre-set Nut

Más vendido

Más vendido

Más vendido

## PG50 50x50

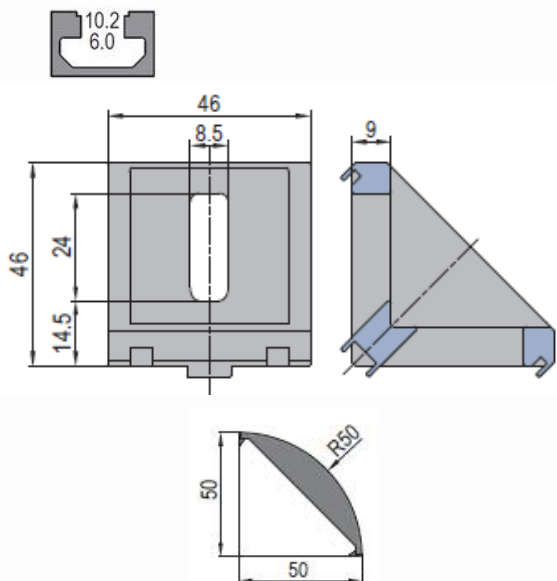



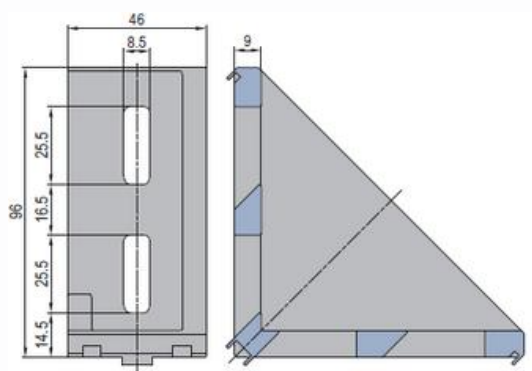



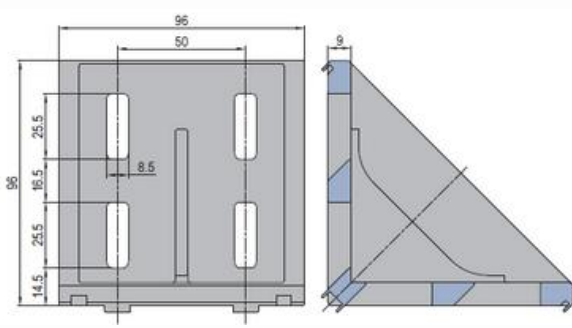



## PG50 50x100



## PG50 100x100



Description	Fastening Set	Mass (g)	Part No.
PG50-50x50 (pcs)		86	3.21.50.5050
PG50-50x50 (set H)	2x <b>H</b>	132	3.21.50.5050.SETH
PG50-50x50 (set J)	2x <b>J</b>	135	3.21.50.5050.SETJ
PG50-50x50 (set K)	2x <b>K</b>	152	3.21.50.5050.SETK
Bracket Cap PG50-5050		9.5	3.22.50.5050
PG50-50x100 (pcs)		235	3.21.50.50100
PG50-50x100 (set H)	4x <b>H</b>	327	3.21.50.50100.SETH
PG50-50x100 (set J)	4x <b>J</b>	333	3.21.50.50100.SETJ
PG50-50x100 (set K)	4x <b>K</b>	365	3.21.50.50100.SETK
PG50-100x100 (pcs)		484	3.21.50.100100
PG50-100x100 (set H)	8x <b>H</b>	668	3.21.50.100100.SETH
PG50-100x100 (set J)	8x <b>J</b>	680	3.21.50.100100.SETJ
PG50-100x100 (set K)	8x <b>K</b>	744	3.21.50.100100.SETK

H	Fastening Set	J	Fastening Set	K	Fastening Set
	M8 Flange Nut		M8x25 Bolt		M8x25 Bolt
	M8x25 T Bolt		M8 Spring Washer		M8 Spring Washer
			M8 Washer		M8 Washer
			M8 T Nut		M8 Pre-set Nut



**Material:** 6063-T6 Aluminium, anodized



Esta conexión tipo T entre perfiles añade fuerza, versatilidad y es de fácil uso.

---

T connection between profiles, adds high strength, good versatility, easy use.

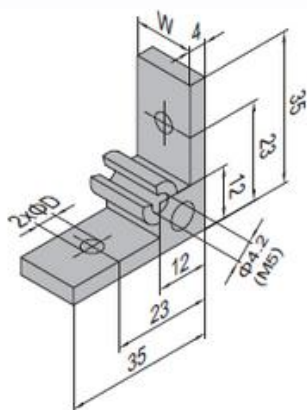

# 35x35x4

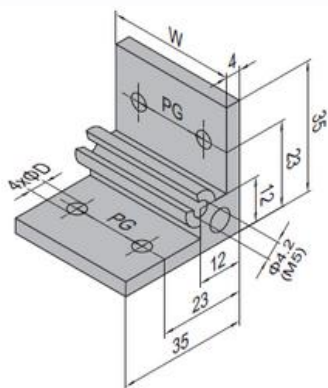

Application	Description	D (mm)	W (mm)	Fastening Set	Machining Code	Mass (g)	Part No.
PG15 15mm 	35-15-15 (pcs)	4.5	10			8	3.31.35.15.15
	35-15-15 (set/)	4.5	10	2xN		20	3.31.35.15.15.SET
	35-15-15 (M5/)	4.5	10		M5	8	3.31.35.15.15.M5
	35-15-15 (M5)	4.5	10	2xN+1xP	M5	22	3.31.35.15.15.M5.SET
PG15 30mm 	35-15-30 (pcs)	4.5	25			21	3.31.35.15.30
	35-15-30 (set)	4.5	25	2xN		33	3.31.35.15.30.SET
	35-15-30 (M5)	4.5	25		M5	21	3.31.35.15.30.M5
	35-15-30 (M5 set )	4.5	25	2xN+1xP	M5	35	3.31.35.15.30.M5.SET
PG20 20mm 	35-20-20 (pcs)	4.5	14			12	3.31.35.20.20
	35-20-20 (set)	4.5	14	2xN		24	3.31.35.20.20.SET
	35-20-20 (M5)	4.5	14		M5	12	3.31.35.20.20.M5
	35-20-20 (M5 set )	4.5	14	2xN+1xP	M5	26	3.31.35.20.20.M5.SET
PG30 30mm 	35-30-30 (pcs)	6.5	22			19	3.31.35.30.30
	35-30-30 (set)	6.5	22	2xR		42	3.31.35.30.30.SET
	35-30-30 (M5)	6.5	22		M5	19	3.31.35.30.30.M5
	35-30-30 (M5 set )	6.5	22	2xR+1xP	M5	44	3.31.35.30.30.M5.SET

# 35x35x4



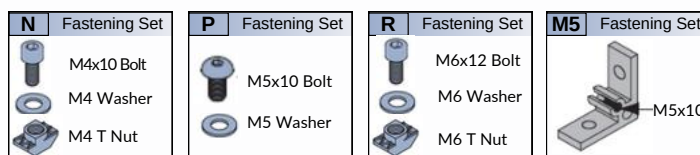

Application	Description	D (mm)	W (mm)	PG (mm)	Fastening Set	Machining Code	Mass (g)	Part No.
 PG20 40mm	35-20-40 (pcs)	4.5	34	20			29	3.31.35.20.40
	35-20-40 (set)	4.5	34	20	4xN		50	3.31.35.20.40.SET
	35-20-40 (M5)	4.5	34	20		M5	29	3.31.35.20.40.M5
	35-20-40 (M5 set)	4.5	34	20	4xN+1xP	M5	52	3.31.35.20.40.M5.SET
 PG30 60mm	35-30-60 (pcs)	6.5	52	30			45	3.31.35.30.60
	35-30-60 (set)	6.5	52	30	4xR		88	3.31.35.30.60.SET
	35-30-60 (M5)	6.5	52	30		M5	45	3.31.35.30.60.M5
	35-30-60 (M5 set)	6.5	52	30	4xR+1xP	M5	90	3.31.35.30.60.M5.SET

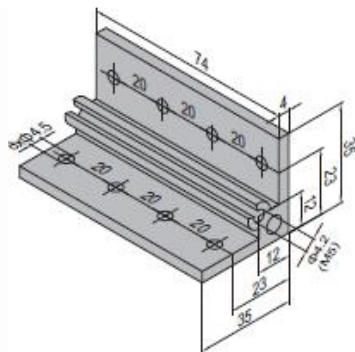
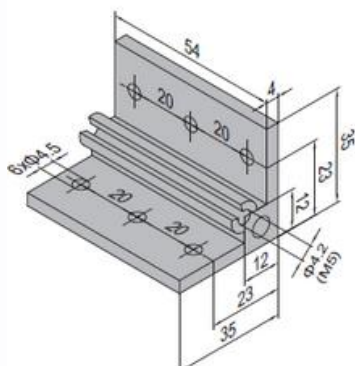

# 35x35x4





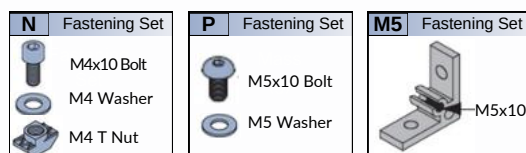

Application	Description	Fastening Set	Machining Code	Mass (g)	Part No.
 PG20 60mm	35-20-60 (pcs)			47	3.31.35.20.60
	35-20-60 (set)	6xN		77	3.31.35.20.60.SET
	35-20-60 (M5)		M5	47	3.31.35.20.60.M5
	35-20-60 (M5 set)	6xN+1xP	M5	79	3.31.35.20.60.M5.SET
 PG20 80mm	35-20-80 (pcs)			64	3.31.35.20.80
	35-20-80 (set)	8xN		103	3.31.35.20.80.SET
	35-20-80 (M5)		M5	64	3.31.35.20.80.M5
	35-20-80 (M5 set)	8xN+1xP	M5	105	3.31.35.20.80.M5.SET

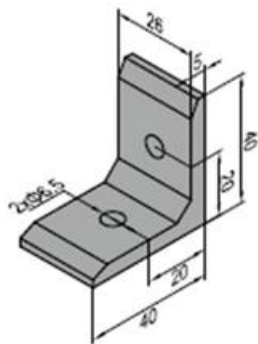

## 40A-30-30





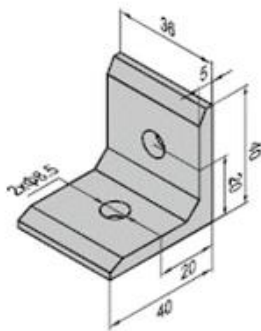

Description	Fastening Set	D (mm)	W (mm)	Mass (g)	Part No.
Angle Profile Bracket 40A-30-30 (SET F)	2xF	6.5	26	41	30.2.04.030030.02.SETF 

F	Fastening Set
	M8x20 Bolt
	M6 Spring Bolt
	M6 T Nut

## 40A-40-40







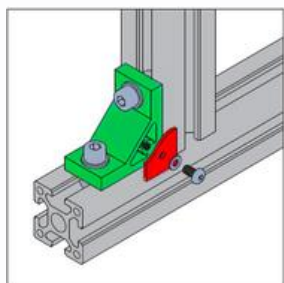
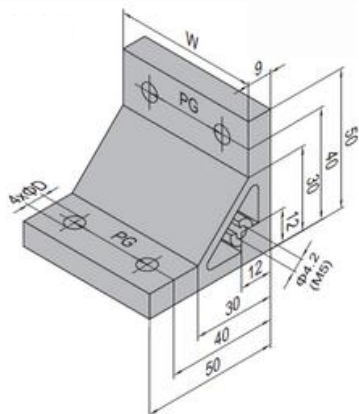

Description	Fastening Set	D (mm)	W (mm)	Mass (g)	Part No.
Angle Profile Bracket 40A-40-40 (SET U)	2xU	8.5	34	81	40.2.04.040040.02.SETU 

U	Fastening Set
	M8x16 Bolt
	M8 Spring Bolt
	M6 T Nut







## 50x50x9

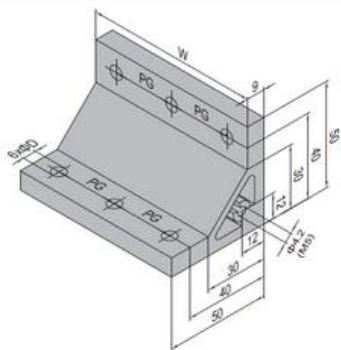

Application	Description	D (mm)	W (mm)	PG (mm)	Fastening Set	Machining Code	Mass (g)	Part No.
<b>PG20</b> <b>40mm</b> 	50-20-40 (pcs)	4.5	34	20			75	3.31.50.20.40
	50-20-40 (set)	4.5	34	20	4xN		95	3.31.50.20.40.SET
	50-20-40 (M5)	4.5	34	20		M5	75	3.31.50.20.40.M5
	50-20-40 (M5 set)	4.5	34	20	4xU+1xP	M5	97	3.31.50.20.40.M5.SET
<b>PG30</b> <b>60mm</b> 	50-30-60 (pcs)	6.5	52	30			114	3.31.50.30.60
	50-30-60 (set)	6.5	52	30	4xV		156	3.31.50.30.60.SET
	50-30-60 (M5)	6.5	52	30		M5	114	3.31.50.30.60.M5
	50-30-60 (M5 set)	6.5	52	30	4xV+1xP	M5	158	3.31.50.30.60.M5.SET
<b>PG40</b> <b>80mm</b> 	50-40-80 (pcs)	8.5	70	40			154	3.31.50.40.80
	50-40-80 (set)	8.5	70	40	4xD		240	3.31.50.40.80.SET
	50-40-80 (M5)	8.5	70	40		M5	154	3.31.50.40.80.M5
	50-40-80 (M5 set)	8.5	70	40	4xD+1xP	M5	242	3.31.50.40.80.M5.SET
<b>PG45</b> <b>90mm</b> 	50-45-90 (pcs)	8.5	80	45			176	3.31.50.45.90
	50-45-90 (set)	8.5	80	45	4xD		262	3.31.50.45.90.SET
	50-45-90 (M5)	8.5	80	45		M5	176	3.31.50.45.90.M5
	50-45-90 (M5 set)	8.5	80	45	4xD+1xP	M5	264	3.31.50.45.90.M5.SET
<b>PG50</b> <b>100mm</b> 	50-50-100 (pcs)	8.5	90	50			198	3.31.50.50.100
	50-50-100 (set)	8.5	90	50	4xD		284	3.31.50.50.100.SET
	50-50-100 (M5)	8.5	90	50		M5	198	3.31.50.50.100.M5
	50-50-100 (M5 set)	8.5	90	50	4xD+1xP	M5	286	3.31.50.50.100.M5.SET





## 50x50x9

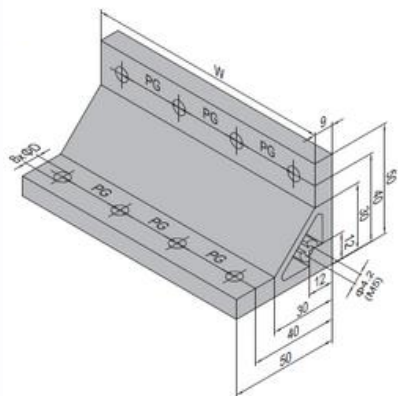

Application	Description	D (mm)	W (mm)	PG (mm)	Fastening Set	Machining Code	Mass (g)	Part No.
<b>PG20</b> <b>60mm</b> 	50-20-60 (pcs)	4.5	54	20			119	3.31.50.20.60
	50-20-60 (set)	4.5	54	20	6xU		147	3.31.50.20.60.SET
	50-20-60 (M5)	4.5	54	20		M5	119	3.31.50.20.60.M5
	50-20-60 (M5 set)	4.5	54	20	6xU+1xP	M5	149	3.31.50.20.60.M5.SET
<b>PG30</b> <b>90mm</b> 	50-30-90 (pcs)	6.5	82	30			180	3.31.50.30.90
	50-30-90 (set)	6.5	82	30	6xV		241	3.31.50.30.90.SET
	50-30-90 (M5)	6.5	82	30		M5	180	3.31.50.30.90.M5
	50-30-90 (M5 set)	6.5	82	30	6xV+1xP	M5	243	3.31.50.30.90.M5.SET
<b>PG40</b> <b>120mm</b> 	50-40-120 (pcs)	8.5	110	40			242	3.31.50.40.120
	50-40-120 (set)	8.5	110	40	6xD		372	3.31.50.40.120.SET
	50-40-120 (M5)	8.5	110	40		M5	242	3.31.50.40.120.M5
	50-40-120 (M5 set)	8.5	110	40	6xD+1xP	M5	374	3.31.50.40.120.M5.SET

50x50x9



Application	Description	D (mm)	W (mm)	PG (mm)	Fastening Set	Machining Code	Mass (g)	Part No.
<b>PG20</b> <b>80mm</b> 	50-20-80 (pcs)	4.5	74	20			163	3.31.50.20.80
	50-20-80 (set)	4.5	74	20	8x <b>U</b>		199	3.31.50.20.80.SET
	50-20-80 ()	4.5	74	20		M5	163	3.31.50.20.80.M5
	50-20-80 (M5 set)	4.5	74	20	8x <b>U</b> +1x <b>P</b>	M5	201	3.31.50.20.80.M5.SET
<b>PG30</b> <b>120mm</b> 	50-30-120 (pcs)	6.5	112	30			246	3.31.50.30.120
	50-30-120 (set)	6.5	112	30	6x <b>V</b>		326	3.31.50.30.120.SET
	50-30-120 (M5)	6.5	112	30		M5	246	3.31.50.30.120.M5
	50-30-120 (M5 set)	6.5	112	30	8x <b>V</b> +1x <b>P</b>	M5	328	3.31.50.30.120.M5.SET
<b>PG40</b> <b>160mm</b> 	50-40-160 (pcs)	8.5	150	40			330	3.31.50.40.160
	50-40-160 (set)	8.5	150	40	8x <b>D</b>		502	3.31.50.40.160.SET
	50-40-160 (M5)	8.5	150	40		M5	330	3.31.50.40.160.M5
	50-40-160 (M5 set)	8.5	150	40	8x <b>D</b> +1x <b>P</b>	M5	504	3.31.50.40.160.M5.SET
<b>PG45</b> <b>180mm</b> 	50-45-180 (pcs)	8.5	170	45			374	3.31.50.45.180
	50-45-180 (set)	8.5	170	45	8x <b>D</b>		546	3.31.50.45.180.SET
	50-45-180 (M5)	8.5	170	45		M5	374	3.31.50.45.180.M5
	50-45-180 (M5 set)	8.5	170	45	8x <b>D</b> +1x <b>P</b>	M5	548	3.31.50.45.180.M5.SET

**U** Fastening Set

- M4x14 Bolt
- M4 Washer
- M4 T Nut

**V** Fastening Set

- M6x16 Bolt
- M6 Washer
- M6 T Nut

**M5** Fastening Set

- M5x10

**D** Fastening Set

- M8x20 Bolt
- M8 Washer
- M8 T Nut

**P** Fastening Set

- M5x10 Bolt
- M5 Washer

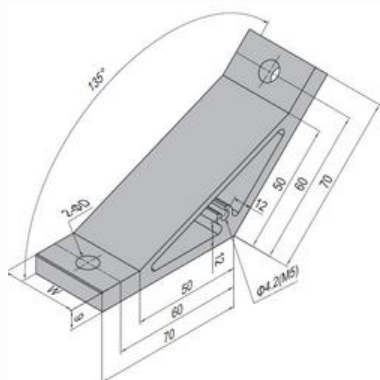

## 70x70x9-135°



Application	Description	D (mm)	W (mm)	Fastening Set	Machining Code	Mass (g)	Part No.
<b>PG30</b> <b>30mm</b> 	70-30-30 (pcs)	7	22			71	3.31.70.30.30
	70-30-30 (set)	7	22	2xV		94	3.31.70.30.30.SET
	70-30-30 (M5)	7	22		M5	71	3.31.70.30.30.M5
	70-30-30 (M5 set)	7	22	2xV+1xP	M5	96	3.31.70.30.30.M5.SET
<b>PG40</b> <b>40mm</b> 	70-40-40 (pcs)	9	30			96	3.31.70.40.40
	70-40-40 (set)	9	30	2xD		142	3.31.70.40.40.SET
	70-40-40 (M5)	9	30		M5	96	3.31.70.40.40.M5
	70-40-40 (M5 set)	9	30	2xD+1xP	M5	144	3.31.70.40.40.M5.SET
<b>PG40</b> <b>60mm</b> 	70-40-60 (set)	9	50			166	3.31.70.40.60
	70-40-60(set)	9	50	2xD		212	3.31.70.40.60.SET
	70-40-60 (M5)	9	50		M5	166	3.31.70.40.60.M5
	70-40-60 (M5 set)	9	50	2xD+1xP	M5	214	3.31.70.40.60.M5.SET
<b>PG45</b> <b>45mm</b> 	70-45-45 (pcs)	9	35			113	3.31.70.45.45
	70-45-45 (set)	9	35	2xD		159	3.31.70.45.45.SET
	70-45-45 (M5)	9	35		M5	113	3.31.70.45.45.M5
	70-45-45 (M5 set)	9	35	2xD+1xP	M5	161	3.31.70.45.45.M5.SET
<b>PG45</b> <b>60mm</b> 	70-45-60 (pcs)	9	50			166	3.31.70.45.60
	70-45-60 (set)	9	50	2xD		212	3.31.70.45.60.SET
	70-45-60 (M5)	9	50		M5	166	3.31.70.45.60.M5
	70-45-60 (M5 set)	9	50	2xD+1xP	M5	214	3.31.70.45.60.M5.SET
<b>PG50</b> <b>50mm</b> 	70-50-50 (pcs)	9	40			131	3.31.70.50.50
	70-50-50 (set)	9	40	2xD		177	3.31.70.50.50.SET
	70-50-50 (M5)	9	40		M5	131	3.31.70.50.50.M5
	70-50-50 (M5 set)	9	40	2xD+1xP	M5	179	3.31.70.50.50.M5.SET
<b>PG60</b> <b>60mm</b> 	70-60-60 (pcs)	9	50			166	3.31.70.60.60
	70-60-60 (set)	9	50	2xD		212	3.31.70.60.60.SET
	70-60-60 (M5)	9	50		M5	166	3.31.70.60.60.M5
	70-60-60 (M5 set)	9	50	2xD+1xP	M5	214	3.31.70.60.60.M5.SET

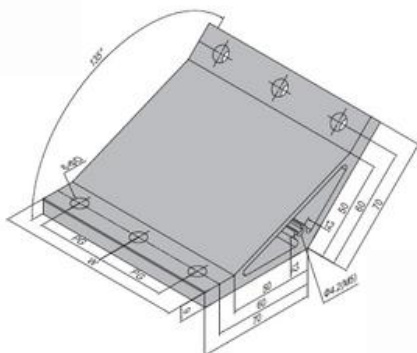

## 70x70x9-135°

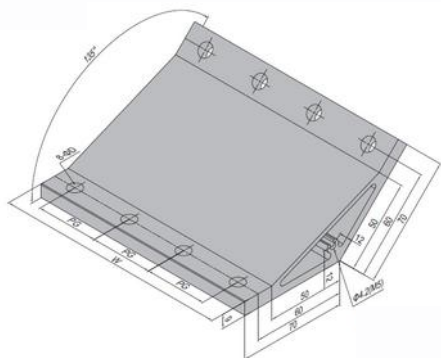

Application	Description	D (mm)	W (mm)	PG (mm)	Fastening Set	Machining Code	Mass (g)	Part No.
<b>PG30</b> <b>90mm</b> 	70-30-90 (pcs)	7	82	30			270	3.31.70.30.90
	70-30-90 (set)	7	82	30	6xV		331	3.31.70.30.90.SET
	70-30-90 (M5)	7	82	30		M5	270	3.31.70.30.90.M5
	70-30-90 (M5 set)	7	82	30	6xV+1xP	M5	333	3.31.70.30.90.M5.SET
<b>PG40</b> <b>120mm</b> 	70-40-120 (pcs)	9	110	40			357	3.31.70.40.120
	70-40-120(set)	9	110	40	6xD		487	3.31.70.40.120.SET
	70-40-120 (M5)	9	110	40		M5	357	3.31.70.40.120.M5
	70-40-120 (M5 set)	9	110	40	6xV+1xP	M5	489	3.31.70.40.120.M5.SET

## 70x70x9-135°





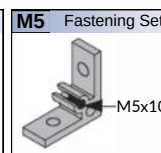
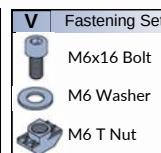
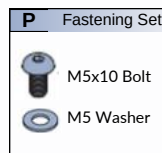
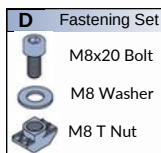

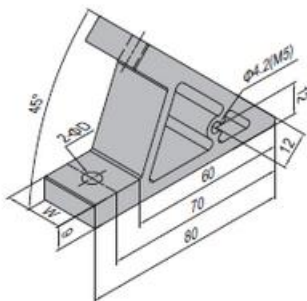

Application	Description	D (mm)	W (mm)	PG (mm)	Fastening Set	Machining Code	Mass (g)	Part No.
<b>PG30</b> <b>120mm</b> 	70-30-120 (pcs)	7	112	30			369	3.31.70.30.120
	70-30-120 (set)	7	112	30	8xV		449	3.31.70.30.120.SET
	70-30-120 (M5)	7	112	30		M5	369	3.31.70.30.120.M5
	70-30-120 (M5 set)	7	112	30	8xV+1xP	M5	451	3.31.70.30.120.M5.SET
<b>PG40</b> <b>160mm</b> 	70-40-160 (pcs)	9	150	40			488	3.31.70.40.160
	70-40-160 (set)	9	150	40	8xD		660	3.31.70.40.160.SET
	70-40-160 (M5)	9	150	40		M5	488	3.31.70.40.160.M5
	70-40-160(M5 set)	9	150	40	8xD+1xP	M5	662	3.31.70.40.160.M5.SET
<b>PG45</b> <b>180mm</b> 	70-45-180 (pcs)	9	170	45			558	3.31.70.45.180
	70-45-180 (set)	9	170	45	8xD		730	3.31.70.45.180.SET
	70-45-180 (M5)	9	170	45		M5	558	3.31.70.45.180.M5
	70-45-180 (M5 set)	9	170	45	8xD+1xP	M5	732	3.31.70.45.180.M5.SET



## 80x80x9-45°



Application	Description	D (mm)	W (mm)	Fastening Set	Machining Code	Mass (g)	Part No.
<b>PG30</b> <b>30mm</b> 	80-30-30 (pcs)	7	22			68	3.31.80.30.30
	80-30-30 (set)	7	22	2xV		91	3.31.80.30.30.SET
	80-30-30 (M5)	7	22		M5	68	3.31.80.30.30.M5
	80-30-30 (M5 set)	7	22	2xV+1xP	M5	93	3.31.80.30.30.M5.SET
<b>PG40</b> <b>40mm</b> 	80-40-40 (pcs)	9	30			29	3.31.80.40.40
	80-40-40 (set)	9	30	2xD		135	3.31.80.40.40.SET
	80-40-40 (M5)	9	30		M5	89	3.31.80.40.40.M5
	80-40-40 (M5 set)	9	30	2xD+1xP	M5	137	3.31.80.40.40.M5.SET
<b>PG40</b> <b>60mm</b> 	80-40-60 (set)	9	50			151	3.31.80.40.60
	80-40-60(set)	9	50	2xD		197	3.31.80.40.60.SET
	80-40-60 (M5)	9	50		M5	151	3.31.80.40.60.M5
	80-40-60 (M5 set)	9	50	2xD+1xP	M5	199	3.31.80.40.60.M5.SET
<b>PG45</b> <b>45mm</b> 	80-45-45 (pcs)	9	35			105	3.31.80.45.45
	80-45-45 (set)	9	35	2xD		151	3.31.80.45.45.SET
	80-45-45 (M5)	9	35		M5	105	3.31.80.45.45.M5
	80-45-45 (M5 set)	9	35	2xD+1xP	M5	153	3.31.80.45.45.M5.SET
<b>PG45</b> <b>60mm</b> 	80-45-60 (pcs)	9	50			151	3.31.80.45.60
	80-45-60 (set)	9	50	2xD		197	3.31.80.45.60.SET
	80-45-60 (M5)	9	50		M5	151	3.31.80.45.60.M5
	80-45-60 (M5 set)	9	50	2xD+1xP	M5	199	3.31.80.45.60.M5.SET
<b>PG50</b> <b>50mm</b> 	80-50-50 (pcs)	9	40			120	3.31.80.50.50
	80-50-50 (set)	9	40	2xD		166	3.31.80.50.50.SET
	80-50-50 (M5)	9	40		M5	120	3.31.80.50.50.M5
	80-50-50 (M5 set)	9	40	2xD+1xP	M5	168	3.31.80.50.50.M5.SET
<b>PG60</b> <b>60mm</b> 	80-60-60 (pcs)	9	50			151	3.31.80.60.60
	80-60-60 (set)	9	50	2xD		197	3.31.80.60.60.SET
	80-60-60 (M5)	9	50		M5	151	3.31.80.60.60.M5
	80-60-60 (M5 set)	9	50	2xD+1xP	M5	199	3.31.80.60.60.M5.SET

## 80x80x9-45°

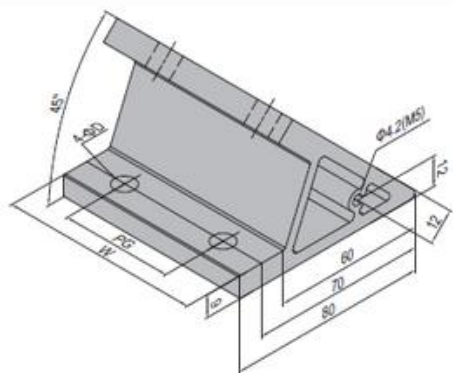

Description	D (mm)	W (mm)	PG (mm)	Fastening Set	Machining Code	Mass (g)	Part No.
80-30-60 (pcs)	7	52	30			156	3.31.80.30.60
80-30-60 (set)	7	52	30	4xV		198	3.31.80.30.60.SET
80-30-60(M5)	7	52	30		M5	156	3.31.80.30.60.M5
80-30-60 (M5 set)	7	52	30	4xV+1xP	M5	200	3.31.80.30.60.M5.SET
80-40-80 (pcs)	9	70	40			209	3.31.80.40.80
80-40-80 (set)	9	70	40	4xD		295	3.31.80.40.80.SET
80-40-80 (M5)	9	70	40		M5	209	3.31.80.40.80.M5
80-40-80 (M5 set)	9	70	40	4xD+1xP	M5	297	3.31.80.40.80.M5.SET
80-45-90 (pcs)	9	80	45			240	3.31.80.45.90
80-45-90 (set)	9	80	45	4xD		326	3.31.80.45.90.SET
80-45-90 (M5)	9	80	45		M5	240	3.31.80.45.90.M5
80-45-90 (M5 set)	9	80	45	4xD+1xP	M5	328	3.31.80.45.90.M5.SET
80-50-100 (pcs)	9	90	50			271	3.31.80.50.100
80-50-100(set)	9	90	50	4xD		357	3.31.80.50.100.SET
80-50-100 (M5)	9	90	50		M5	271	3.31.80.50.100.M5
80-50-100 (M5 set)	9	90	50	4xD+1xP	M5	359	3.31.80.50.100.M5.SET

## 80x80x9-45°

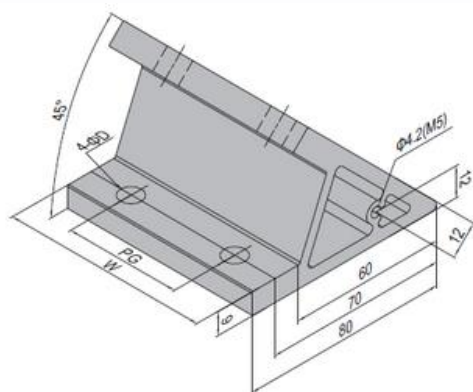

Description	D (mm)	W (mm)	PG (mm)	Fastening Set	Machining Code	Mass (g)	Part No.
80-30-90 (pcs)	7	82	30			247	3.31.80.30.90
80-30-90 (set)	7	82	30	6xV		308	3.31.80.30.90.SET
80-30-90(M5)	7	82	30		M5	247	3.31.80.30.90.M5
80-30-90 (M5 set)	7	82	30	6xV+1xP	M5	310	3.31.80.30.90.M5.SET
80-40-120 (pcs)	9	110	40			329	3.31.80.40.120
80-40-120 (set)	9	110	40	6xD		459	3.31.80.40.120.SET
80-40-120 (M5)	9	110	40		M5	329	3.31.80.40.120.M5
80-40-120 (M5 set)	9	110	40	6xD+1xP	M5	461	3.31.80.40.120.M5.SET

## 80x80x9-45°

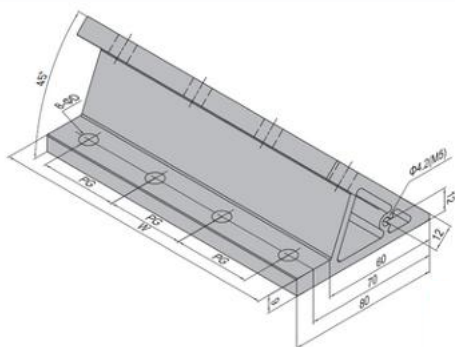

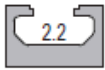
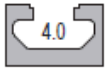
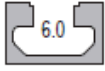

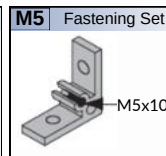
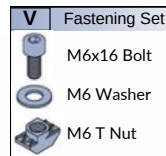
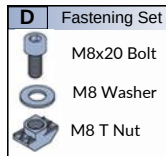

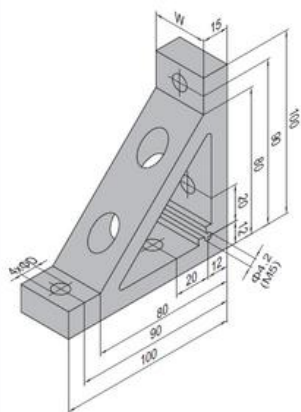

Application	Description	D (mm)	W (mm)	PG (mm)	Fastening Set	Machining Code	Mass (g)	Part No.
<b>PG30</b> <b>120mm</b> 	80-30-120 (pcs)	7	112	30			337	3.31.80.30.120
	80-30-120 (set)	7	112	30	8xV		417	3.31.80.30.120.SET
	80-30-120 (M5)	7	112	30		M5	337	3.31.80.30.120.M5
	80-30-120 (M5 set)	7	112	30	8xV+1xP	M5	419	3.31.80.30.120.M5.SET
<b>PG40</b> <b>160mm</b> 	80-40-160 (pcs)	9	150	40			449	3.31.80.40.160
	80-40-160 (set)	9	150	40	8xD		621	3.31.80.40.160.SET
	80-40-160 (M5)	9	150	40		M5	449	3.31.80.40.160.M5
	80-40-160 (M5 set)	9	150	40	8xD+1xP	M5	623	3.31.80.40.160.M5.SET
<b>PG45</b> <b>180mm</b> 	80-45-180 (pcs)	9	170	45			510	3.31.80.45.180
	80-45-180 (set)	9	170	45	8xD		682	3.31.80.45.180.SET
	80-45-180 (M5)	9	170	45		M5	510	3.31.80.45.180.M5
	80-45-180 (M5 set)	9	170	45	8xD+1xP	M5	684	3.31.80.45.180.M5.SET







# 100x100x15

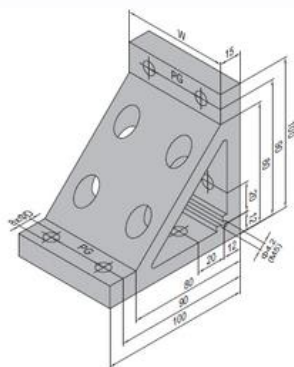

Application	Description	D (mm)	W (mm)	Fastening Set	Machining Code	Mass (g)	Part No.
PG40 40mm 	100-40-40 (pcs)	9	30			220	3.31.100.40.40
	100-40-40 (set)	9	30	2xW+2xJ		324	3.31.100.40.40.SET
	100-40-40 (M5)	9	30		M5	220	3.31.100.40.40.M5
	100-40-40 (M5 set)	9	30	2xW+2xJ+1xP	M5	326	3.31.100.40.40.M5.SET
PG40 60mm 	100-40-60 (pcs)	9	50			386	3.31.100.40.60
	100-40-60 (set)	9	50	2xW+2xJ		490	3.31.100.40.60.SET
	100-40-60 (M5)	9	50		M5	386	3.31.100.40.60.M5
	100-40-60 (M5 set)	9	50	2xW+2xJ+1xP	M5	492	3.31.100.40.60.M5.SET
PG45 45mm 	100-45-45 (pcs)	9	35			261	3.31.100.45.45
	100-45-45 (set)	9	35	2xW+2xJ		365	3.31.100.45.45.SET
	100-45-45 (M5)	9	35		M5	261	3.31.100.45.45.M5
	100-45-45 (M5 set)	9	35	2xW+2xJ+1xP	M5	367	3.31.100.45.45.M5.SET
PG45 60mm 	100-45-60 (pcs)	9	50			386	3.31.100.45.60
	100-45-60 (set)	9	50	2xW+2xJ		490	3.31.100.45.60.SET
	100-45-60 (M5)	9	50		M5	386	3.31.100.45.60.M5
	100-45-60 (M5 set)	9	50	2xW+2xJ+1xP	M5	492	3.31.100.45.60.M5.SET
PG50 50mm 	100-50-50 (pcs)	9	40			303	3.31.100.50.50
	100-50-50 (set)	9	40	2xW+2xJ		407	3.31.100.50.50.SET
	100-50-50 (M5)	9	40		M5	303	3.31.100.50.50.M5
	100-50-50 (M5 set)	9	40	2xW+2xJ+1xP	M5	409	3.31.100.50.50.M5.SET
PG60 60mm 	100-60-60 (pcs)	9	50			386	3.31.100.60.60
	100-60-60 (set)	9	50	2xW+2xJ		490	3.31.100.60.60.SET
	100-60-60 (M5)	9	50		M5	386	3.31.100.60.60.M5
	100-60-60 (M5 set)	9	50	2xW+2xJ+1xP	M5	492	3.31.100.60.60.M5.SET



# 100x100x15

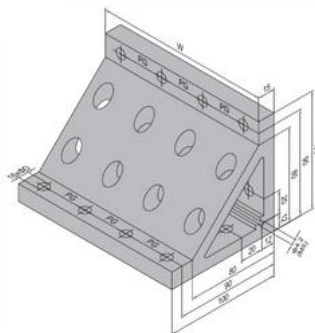
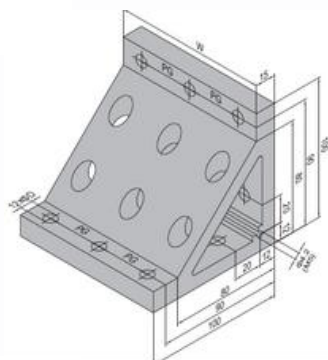

Application	Description	D (mm)	W (mm)	PG (mm)	Fastening Set	Machining Code	Mass (g)	Part No.
PG40 80mm 	100-40-80 (pcs)	9	70	40			522	3.31.100.40.80
	100-40-80 (set)	9	70	40	4xW+4xJ		730	3.31.100.40.80.SET
	100-40-80 (M5)	9	70	40		M5	522	3.31.100.40.80.M5
	100-40-80 (M5 set)	9	70	40	4xW+4xJ+1xP	M5	732	3.31.100.40.80.M5.SET
PG45 90mm 	100-45-90 (pcs)	9	80	45			605	3.31.100.45.90
	100-45-90 (set)	9	80	45	4xW+4xJ		813	3.31.100.45.90.SET
	100-45-90 (M5)	9	80	45		M5	605	3.31.100.45.90.M5
	100-45-90 (M5 set)	9	80	45	4xW+4xJ+1xP	M5	815	3.31.100.45.90.M5.SET
PG50 100mm 	100-50-100 (pcs)	9	90	50			688	3.31.100.50.100
	100-50-100 (set)	9	90	50	4xW+4xJ		896	3.31.100.50.100.SET
	100-50-100 (M5)	9	90	50		M5	688	3.31.100.50.100.M5
	100-50-100 (M5 set)	9	90	50	4xW+4xJ+1xP	M5	898	3.31.100.50.100.M5.SET

**100x100x15**









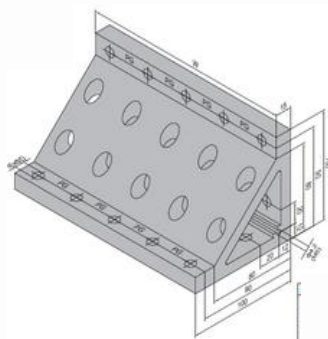





Application	Description	D (mm)	W (mm)	PG (mm)	Fastening Set	Machining Code	Mass (g)	Part No.
<b>PG40</b> <b>160mm</b> 	100-40-160 (pcs)	9	150	40			1127	3.31.100.40.160
	100-40-160 (set)	9	150	40	8xW+8xJ		1543	3.31.100.40.160.SET
	100-40-160 (M5)	9	150	40		M5	1127	3.31.100.40.160.M5
	100-40-160 (M5 set)	9	150	40	8xW+8xJ+1xP	M5	1545	3.31.100.40.160.M5.SET
<b>PG45</b> <b>180mm</b> 	100-45-180 (pcs)	9	170	45			1293	3.31.100.45.180
	100-45-180 (set)	9	170	45	8xW+8xJ		1709	3.31.100.45.180.SET
	100-45-180 (M5)	9	170	45		M5	1293	3.31.100.45.180.M5
	100-45-180 (M5 set)	9	170	45	8xW+8xJ+1xP	M5	1711	3.31.100.45.180.M5.SET

Application	Description	D (mm)	W (mm)	PG (mm)	Fastening Set	Machining Code	Mass (g)	Part No.
<b>PG40</b> <b>120mm</b> 	100-40-120 (pcs)	9	110	40			824	3.31.100.40.120
	100-40-120 (set)	9	110	40	6xW+6xJ		1136	3.31.100.40.120.SET
	100-40-120 (M5)	9	110	40		M5	824	3.31.100.40.120.M5
	100-40-120 (M5 set)	9	110	40	6xW+6xJ+6xP	M5	1138	3.31.100.40.120.M5.SET

**100x100x15**



Application	Description	D (mm)	W (mm)	PG (mm)	Fastening Set	Machining Code	Mass (g)	Part No.
<b>PG40</b> <b>200mm</b> 	100-40-200 (pcs)	9	190	40			1477	3.31.100.40.200
	100-40-200 (set)	9	190	40	10xW+10xJ		1893	3.31.100.40.200.SET
	100-40-200 (M5)	9	190	40		M5	1477	3.31.100.40.200.M5
	100-40-200 (M5 set)	9	190	40	10xW+10xJ+1xP	M5	1895	3.31.100.40.200.M5.SET

<b>P</b> Fastening Set  M5x10 Bolt  M5 Washer	<b>W</b> Fastening Set  M8x30 Bolt  M8 Spring Washer  M8 Washer  M8 T Nut	<b>J</b> Fastening Set  M8x25 Bolt  M8 Spring Washer  M8 Washer  M8 T Nut	<b>M5</b> Fastening Set  M5x10 Bolt
---	---	---	---

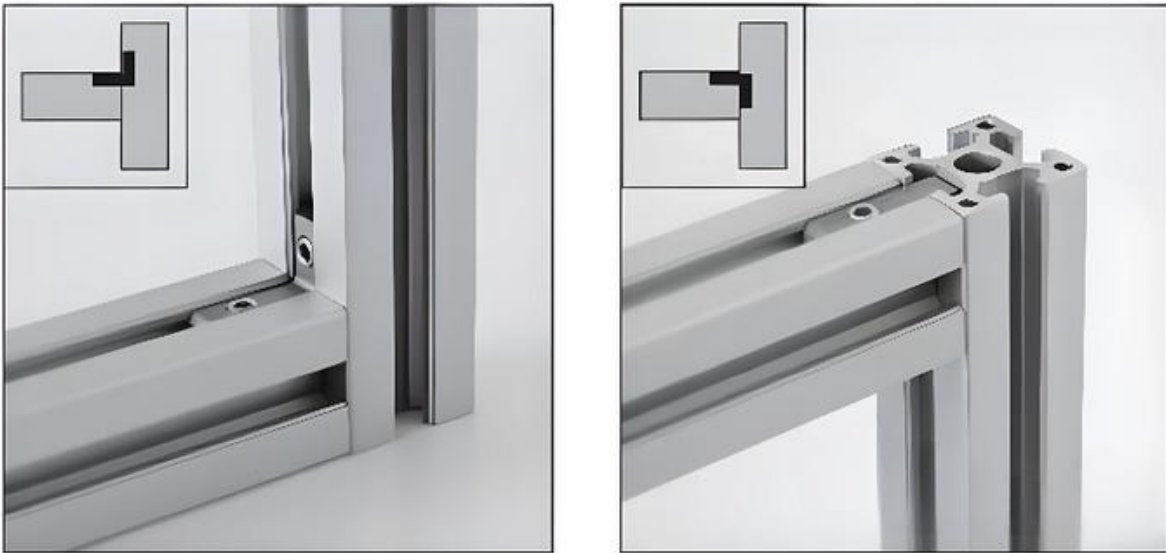

**Material:** Bracket-die cast zinc

El tornillo interno es de bajo costo y gran eficiencia. Comúnmente usado para el ensamble de puertas, ventanas y marcos de protección

---

Inner bracket is with low cost and high efficiency, widely used for the assembly of door, window and protection frame.

**6-A 3.41.06A**  
**6-B 3.41.06B**

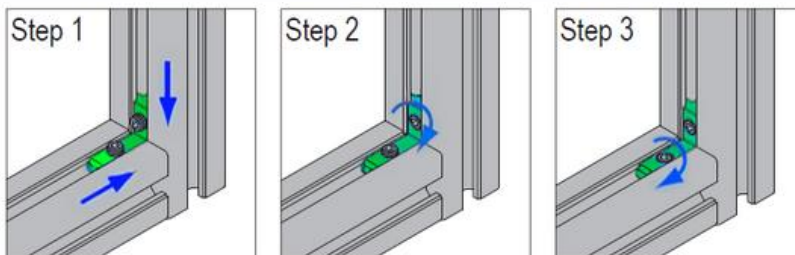
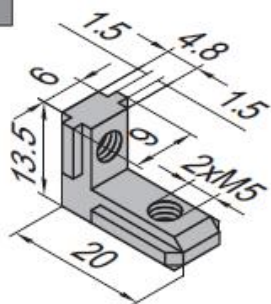

**8-A 3.41.08A**  
**8-B 3.41.08B**

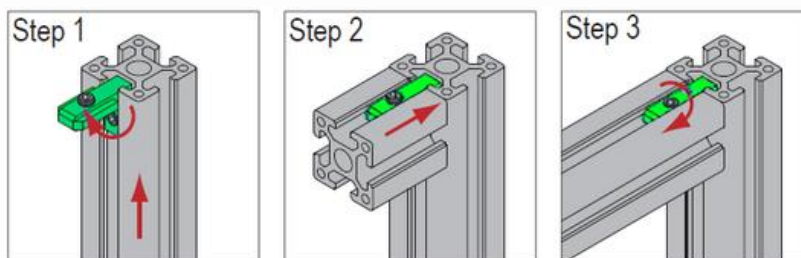
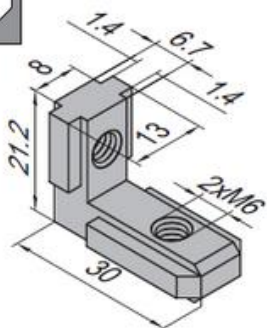
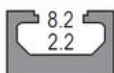

**10-A 3.41.010A**  
**10-B 3.41.010B**

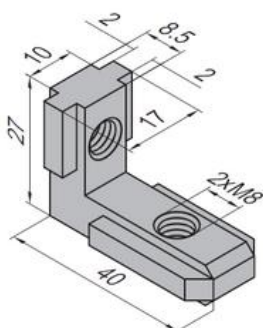

Description	Mass (g/pcs)	Part No.
Inner Bracket-6-A (with top thread)	6	3.41.06A
Inner Bracket-6-B (with top thread)	6	3.41.06B
Inner Bracket-8-A (with top thread)	18	3.41.08A
Inner Bracket-8-B (with top thread)	18	3.41.08B
Inner Bracket-10-A (with top thread)	36	3.41.10A
Inner Bracket-10-B (with top thread)	36	3.41.10B



**Material:** Zinc plated Steel

El tornillo lineal es otra opción de conexión entre perfiles. Ofrece poca fuerza pero va escondido en la ranura.

---

Linear connection between profiles. Low strength, hidden in slot

## Linear Bar Connector-6

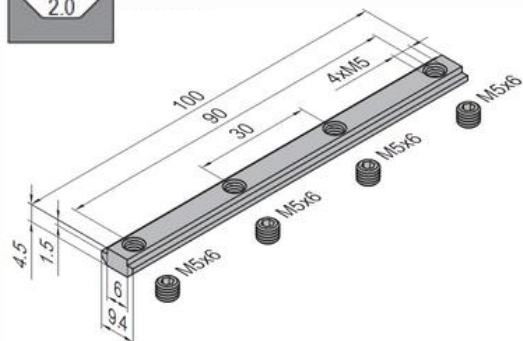

## Linear Bar Connector-8

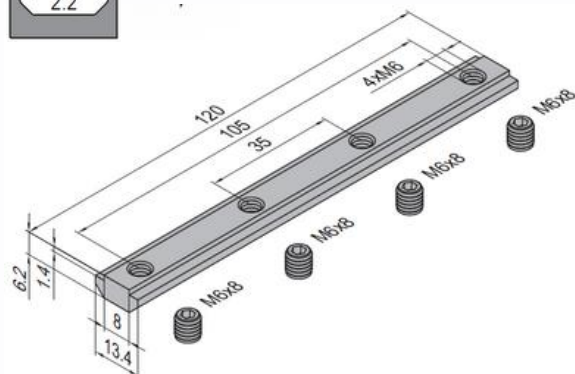
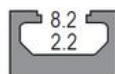

## Linear Bar Connector-10

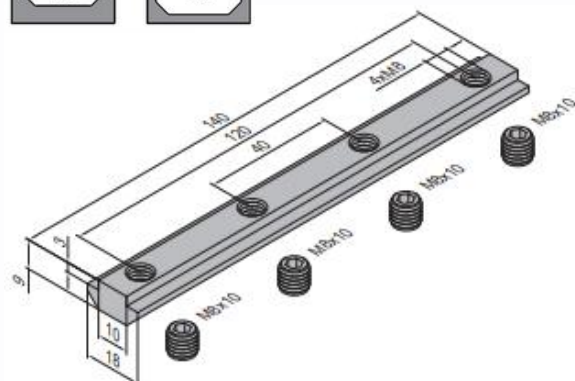

Description	Mass (g/pcs)	Part No.
Linear Bar Connector-6 (with top thread)	27	3.51.06
Linear Bar Connector-8 (with top thread)	65	3.51.08
<b>Linear Bar Connector-10 (with top thread)</b>	132	<b>3.51.10</b>



# Joining Plate

Elementos de unión



**Material:** Zinc plated Steel

## PG30-3030-01

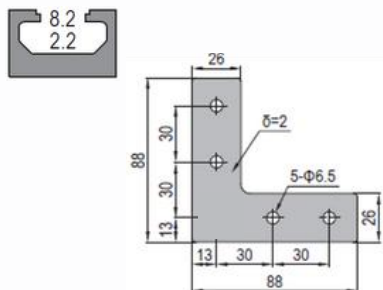

## PG30-3030-02

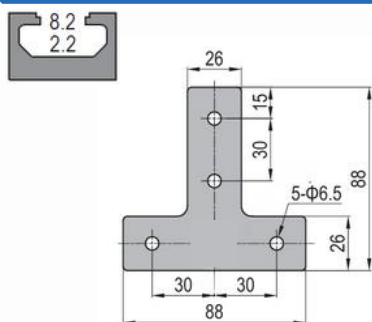

## PG30-3030-03

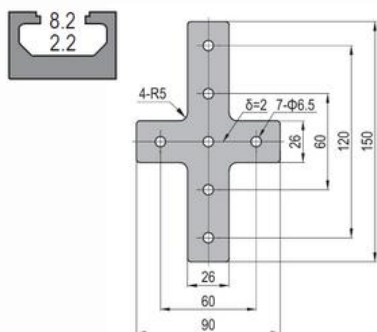

Description	Fastening Set	Mass (g/pcs)	Part No.
<b>PG30-3030-01 (pcs)</b>		58	<b>3.53.30.3030.01</b>
PG30-3030-01 (set A)	4x <b>PG</b>	92	3.53.30.3030.01.SETA
PG30-3030-01 (set B)	4x <b>PH</b>	112	3.53.30.3030.01.SETB
<b>PG30-3030-02 (pcs)</b>		58	<b>3.53.30.3030.02</b>
PG30-3030-02 (set A)	4x <b>PG</b>	92	3.53.30.3030.02.SETA
PG30-3030-02 (set B)	4x <b>PH</b>	112	3.53.30.3030.02.SETB
<b>PG30-3030-03 (pcs)</b>		83	<b>3.53.30.3030.03</b>
PG30-3030-03 (set A)	7x <b>PG</b>	130	3.53.30.3030.03.SETA
PG30-3030-03 (set B)	7x <b>PH</b>	158	3.53.30.3030.03.SETB

## PG40-4040-01

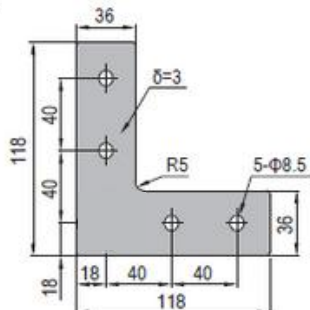

## PG40-4040-02

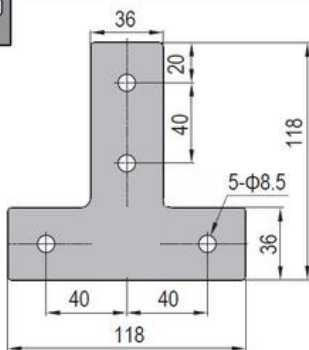



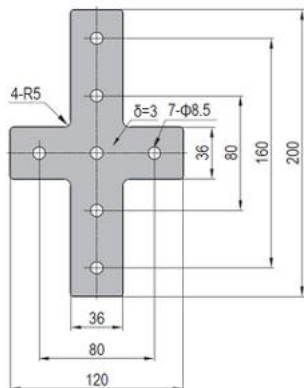



## PG40-4040-03



Description	Fastening Set	Mass (g/pcs)	Part No.
PG40-4040-01 (pcs)		147	3.53.40.4040.01
<b>PG40-4040-01 (set X)</b>	<b>4xX</b>	217	<b>3.53.40.4040.01.SETX</b>
PG40-4040-01 (set Y)	4xY	257	3.53.40.4040.01.SETY
PG40-4040-02 (pcs)		149	3.53.40.4040.02
PG40-4040-02 (set X)	4xX	219	3.53.40.4040.02.SETX
PG40-4040-02 (set Y)	4xY	259	3.53.40.4040.02.SETY
PG40-4040-03 (pcs)		230	3.53.40.4040.03
PG40-4040-03 (set X)	7xX	328	3.53.40.4040.03.SETX
PG40-4040-03 (set Y)	7xY	384	3.53.40.4040.03.SETY



X	Fastening Set	Y	Fastening Set
	M8x12 Bolt		M8x12 Bolt
	M8 Spring Washer		M8 Spring Washer
	M8 T Nut		M8 Pre-set Nut

## PG40-4040-04

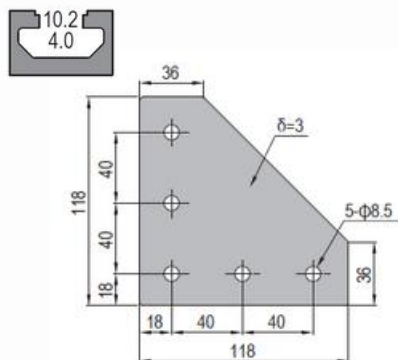



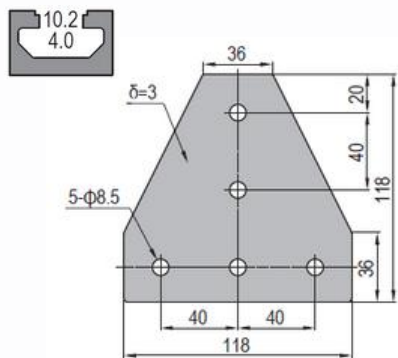

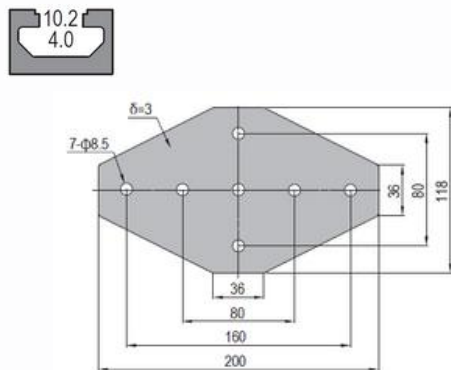

## PG40-4040-05



## PG40-4040-06



Description	Fastening Set	Mass (g)	Part No.
PG40-4040-04 (pcs)		222	3.53.40.4040.04
<b>PG40-4040-04 (set X)</b>	5xX	292	<b>3.53.40.4040.04.SETX</b> 
PG40-4040-04 (set Y)	5xY	332	3.53.40.4040.04.SETY
PG40-4040-05 (pcs)		220	3.53.40.4040.05
PG40-4040-05 (set X)	5xX	290	3.53.40.4040.05.SETX
PG40-4040-05 (set Y)	5xY	330	3.53.40.4040.05.SETY
PG40-4040-06 (pcs)		355	3.53.40.4040.06
PG40-4040-06 (set X)	7xX	453	3.53.40.4040.06.SETX
PG40-4040-06 (set Y)	7xY	510	3.53.40.4040.06.SETY

X	Fastening Set	Y	Fastening Set
	M8x12 Bolt		M8x12 Bolt
	M8 Spring Washer		M8 Spring Washer
	M8 T Nut		M8 Pre-set Nut

## PG40-4080-01

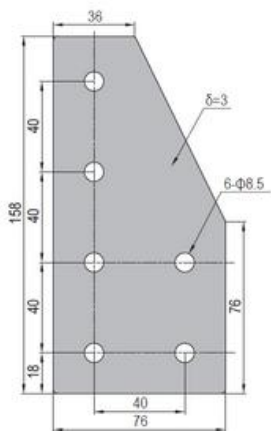

## PG40-4080-02

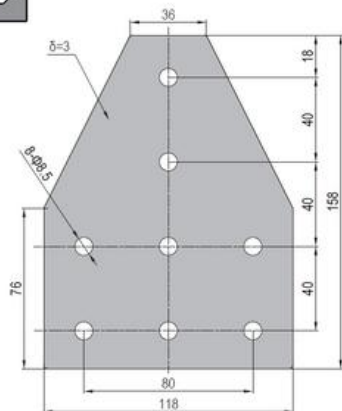
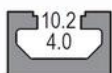



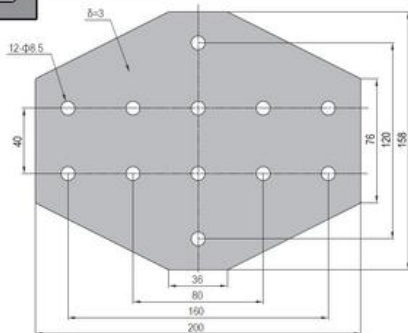



## PG40-4080-03



Description	Fastening Set	Mass (g)	Part No.
PG40-4080-01 (pcs)		222	3.53.40.4080.01
<b>PG40-4080-01 (set X)</b>	6x <b>X</b>	306	<b>3.53.40.4080.01.SETX</b>
PG40-4080-01 (set Y)	6x <b>Y</b>	354	3.53.40.4080.01.SETY
PG40-4080-02 (pcs)		347	3.53.40.4080.02
PG40-4080-02 (set X)	8x <b>X</b>	459	3.53.40.4080.02.SETX
PG40-4080-02 (set Y)	8x <b>Y</b>	523	3.53.40.4080.02.SETY
PG40-4080-03 (pcs)		523	3.53.40.4080.03
PG40-4080-03 (set X)	12x <b>X</b>	691	3.53.40.4080.03.SETX
PG40-4080-03 (set Y)	12x <b>Y</b>	787	3.53.40.4080.03.SETY



X	Fastening Set	Y	Fastening Set
	M8x12 Bolt		M8x12 Bolt
	M8 Spring Washer		M8 Spring Washer
	M8 T Nut		M8 Pre-set Nut



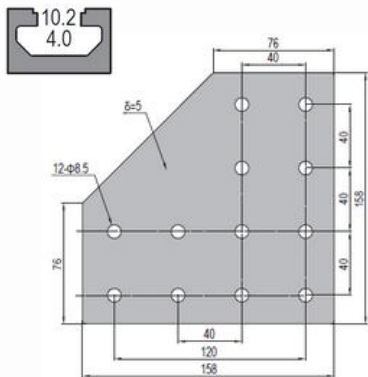



## PG40-8080-01

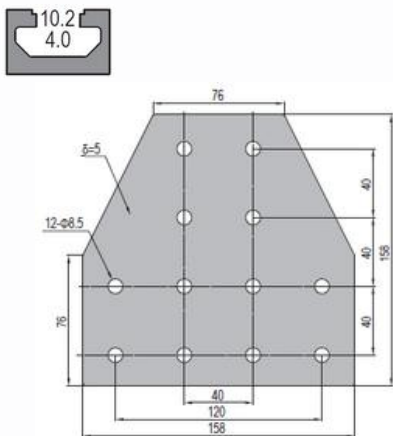

Description	Fastening Set	Mass (g)	Part No.
PG40-8080-01 (pcs)		730	3.53.40.8080.01
PG40-8080-01 (set I)	12xI	910	3.53.40.8080.01.SETX
PG40-8080-01 (set O)	12xO	1006	3.53.40.8080.01.SETY
PG40-8080-02 (pcs)		731	3.53.40.8080.02
PG40-8080-02 (set I)	12xI	911	3.53.40.8080.02.SETX
PG40-8080-02 (set O)	12xO	1007	3.53.40.8080.02.SETY
PG40-8080-03 (pcs)		1043	3.53.40.8080.03
PG40-8080-03 (set I)	16xI	1283	3.53.40.8080.03.SETX
PG40-8080-03 (set O)	16xO	1411	3.53.40.8080.03.SETY

## PG40-8080-02



I Fastening Set	O Fastening Set
 M8x16 Bolt	 M8x16 Bolt
 M8 Spring Washer	 M8 Spring Washer
 M8 T Nut	 M8 Pre-set Nut

## PG40-8080-03

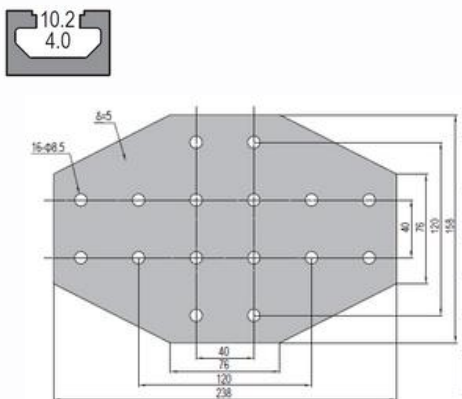

## PG45-4545-01

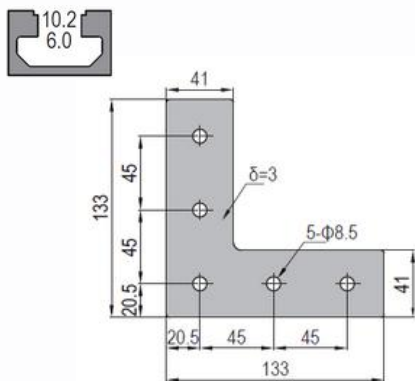



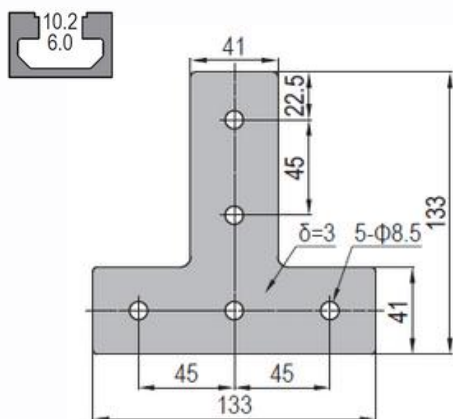



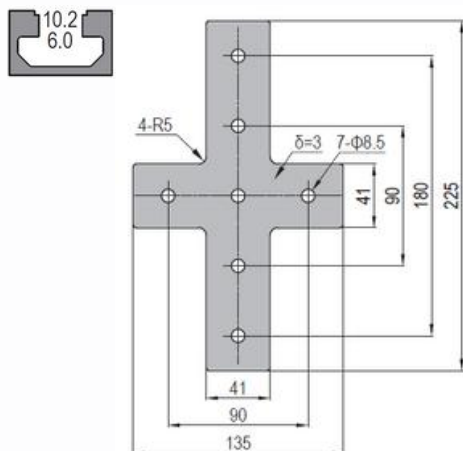

## PG45-4545-02



## PG45-4545-03



Description	Fastening Set	Mass (g)	Part No.
PG45-4545-01 (pcs)		209	3.53.45.4545.01
<b>PG45-4545-01 (set I)</b>	5xI	288	<b>3.53.45.4545.01.SETI</b> 
PG45-4545-01 (set O)	5xO	328	3.53.45.4545.01.SETO
PG45-4545-02 (pcs)		209	3.53.45.4545.02
<b>PG45-4545-02 (set I)</b>	5xI	288	<b>3.53.45.4545.02.SETI</b> 
PG45-4545-02 (set O)	5xO	328	3.53.45.4545.02.SETO
PG45-4545-03 (pcs)		297	3.53.45.4545.03
PG45-4545-03 (set I)	7xI	408	3.53.45.4545.03.SETI
PG45-4545-03 (set O)	7xO	464	3.53.45.4545.03.SETO

I	Fastening Set	O	Fastening Set
	M8x16 Bolt		M8x16 Bolt
	M8 Spring Washer		M8 Spring Washer
	M8 T Nut		M8 Pre-set Nut

# Butt Connector

Elementos de unión

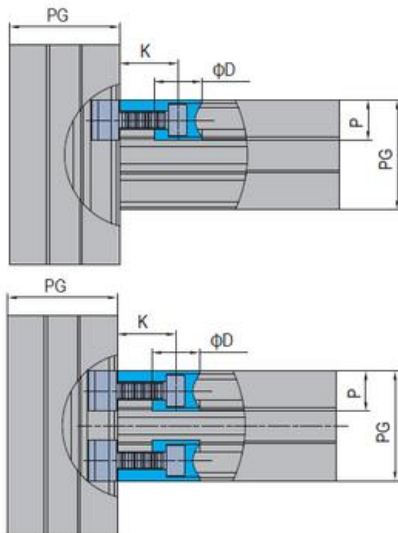

**Material:** Zinc alloy, nickel plated

El conector interno es comúnmente utilizado en cuarto limpio.

Butt connector is used for profile affiliating connection and widely used in clean room.

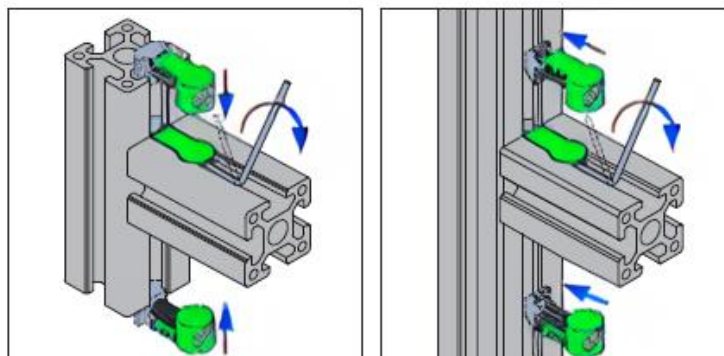

## Butt Connector-8

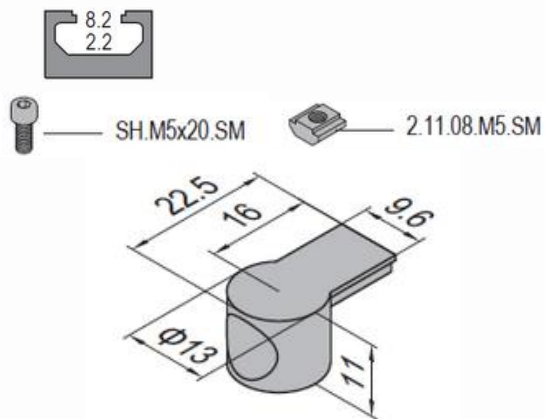

## Butt Connector-10

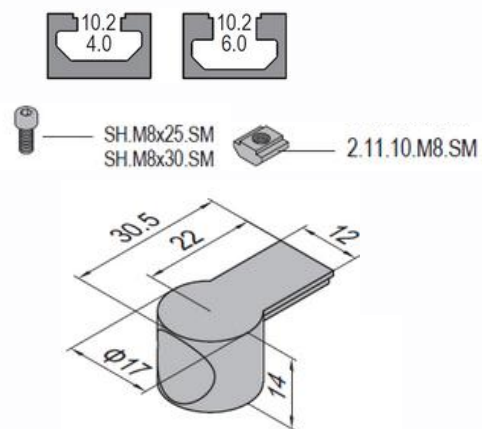

Description	PG	K (mm)	D (mm)	P (mm)	Fastening Set	Mass (g)	Part No.
Butt Connector-8 (pcs)	PG30	16	13	11		9	3.61.08
Butt Connector-8 (set A)	PG30	16	13	11	1xQ	20	3.61.08.SETA
Butt Connector-8 (set B)	PG30	16	13	11	1xPG	18	3.61.08.SETB
Butt Connector-10 (pcs)	PG40/PG45/PG50/PG60	22	17	14		15	3.61.10
Butt Connector-10-4 (set A)	PG40	22	17	14	1xT	41	3.61.10.04.SETA
Butt Connector-10-4 (set B)	PG40	22	17	14	1xCD	37	3.61.10.04.SETB
Butt Connector-10-6 (set A)	PG45/PG50/PG60	22	17	14	1xS	43	3.61.10.06.SETA
Butt Connector-10-6 (set B)	PG45/PG50/PG60	22	17	14	1xCE	39	3.61.10.06.SETB

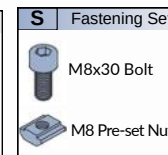
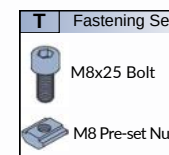
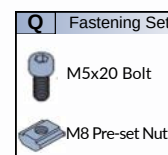
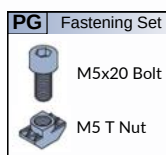

# End Connector

## Elementos de unión



**Material:** Nickel plated steel

También llamado conector de mariposa por su forma, puede esconderse completamente dentro del perfil, por esto es comúnmente usado para cuarto limpio.

End connector is also called butterfly connector due to its shape, which can hide itself completely in aluminium profile. It is widely used for frame structures in clean room.

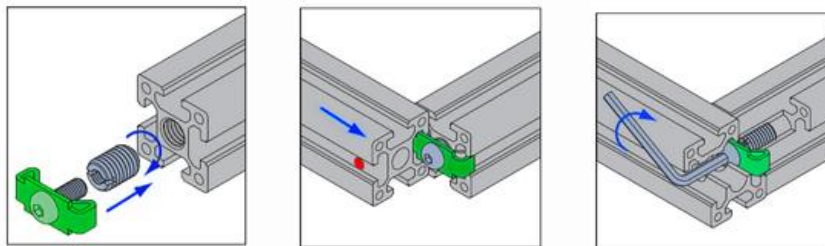



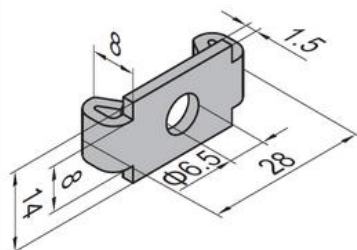
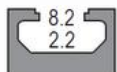

## End Connector-8

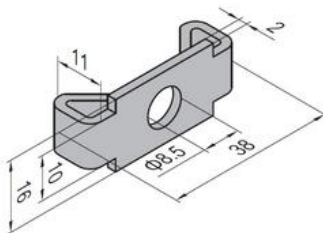

## End Connector-10



Description	PG	Fastening Set	Mass (g)	Part No.
End Connector-8 (pcs)	PG30		7	3.71.30
End Connector-8 (set)	PG30	1x <b>FA</b>	23	3.71.30.SET
End Connector-10 (pcs)	PG40		13	3.71.40
End Connector-10 (set)	PG40	1x <b>FB</b>	38	3.71.40.SET

<b>FA</b>	Fastening Set	<b>FB</b>	Fastening Set
	M6x20 Bolt		M8x20 Bolt
	M12-M6 Hole Reducer Bolt		M14-M8 Hole Reducer Bolt

# Screw Connector

Elementos de unión

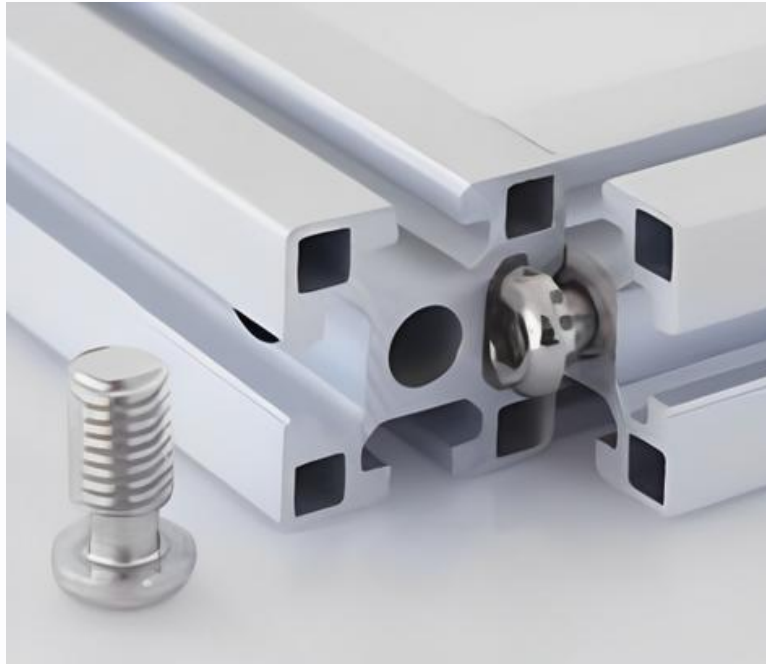

**Material:** Nickel plated steel

Una manera simple y económica de remplazar al End connector con una conexión más confiable.

A simple and economic way to replace end connector with more connection reliability.

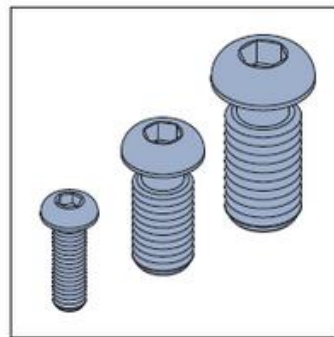
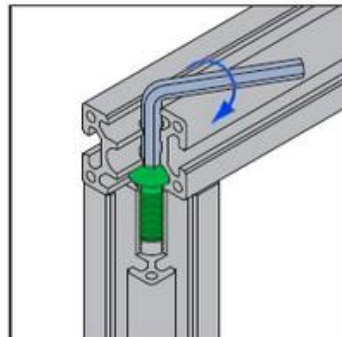

## Screw Connector-6

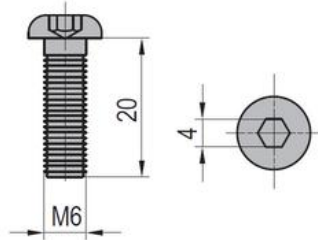

## Screw Connector-8

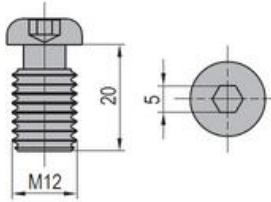

## Screw Connector-10

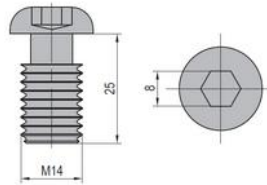

Requiere hacer roscas internas previamente

Description	Mass (g)	Part No.
Screw Connector-6	7	3.81.06
Screw Connector-8	17	3.81.08
Screw Connector-10	31	3.81.10
Direct replacement for Screw Connector-6	7	BH.M08.16

Autorroscable. No requiere rosca previa.

Description	Mass (g)	Part No.
Self tapping Bolt - 8	19	3.82.08
Self tapping Bolt - 10	35	3.82.10

# Cubic Connector

Elementos de unión



**Material:** Connector- Die cast aluminium  
Cap- Black ABS

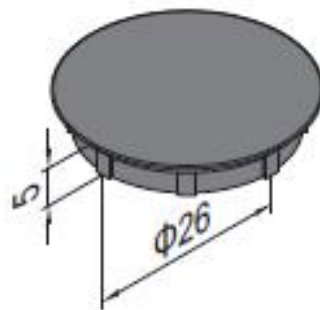

## Cubic Connector-4545-2

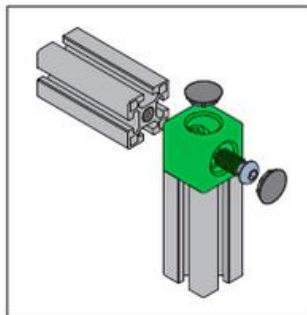
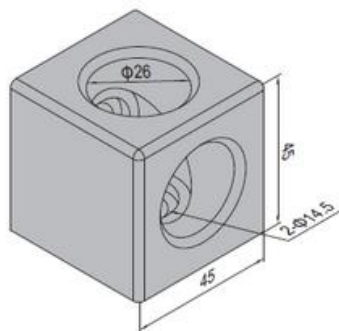
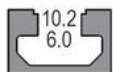

## Cubic Connector-4545-3

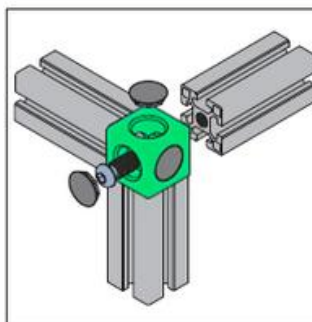
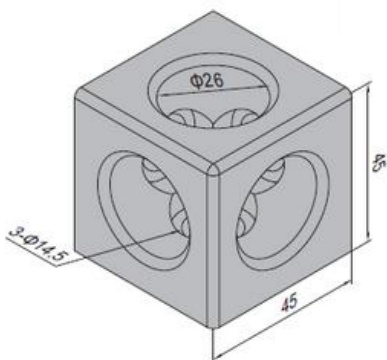

Description	Fastening Set	Cap (pcs)	Mass (g)	Part No.
Cubic Connector-4545-2 (pcs)		2	135	3.91.4545.02
Cubic Connector-4545-2 (set)	2x(M14x25)	2	201	3.91.4545.02.SET
Cubic Connector-4545-2(pcs)		3	135	3.91.4545.03
Cubic Connector-4545-3 (set)	3x(M14x25)	3	234	3.91.4545.03.SET

## Conector 3 entradas

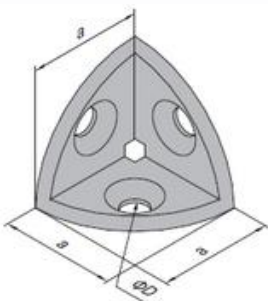

## Cap-01

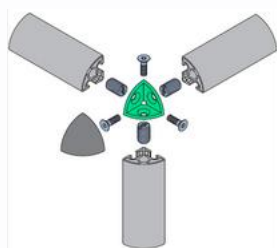
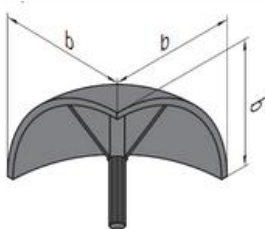
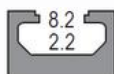

## Cap-02

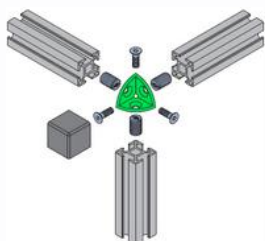
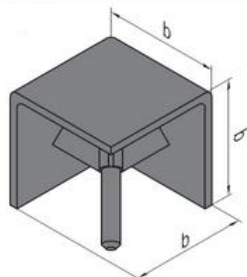

Description	a	b	D	Fastening Set	Cap (pcs)	Mass (g)	Part No.
2020-01 (pcs)	18.5	20	6.5		1	11	3.92.2020.01
2020-01 (set)	18.5	20	6.5	3xDY	1	23	3.92.2020.01.SET
2020-02 (pcs)	18.5	20	6.5		1	12	3.92.2020.02
2020-02 (set)	18.5	20	6.5	3xDY	1	24	3.92.2020.02.SET
3030-01 (pcs)	28	30	6.5		1	35	3.92.3030.01
3030-01 (set)	28	30	6.5	3xCW	1	105	3.92.3030.01.SET
3030-02 (pcs)	28	30	6.5		1	38	3.92.3030.02
3030-02 (set)	28	30	6.5	3xCW	1	108	3.92.3030.02.SET
4040-01 (pcs)	38	40	8.5		1	87	3.92.4040.01
4040-01 (set)	38	40	8.5	3xFI	1	159	3.92.4040.01.SET
4040-02 (pcs)	38	40	8.5		1	92	3.92.4040.02
4040-02 (set)	38	40	8.5	3xFI	1	164	3.92.4040.02.SET
4545-01 (pcs)	42	45	8.5		1	114	3.92.4545.01
4545-01 (set)	42	45	8.5	3xFI	1	187	3.92.4545.01.SET
4545-02 (pcs)	42	45	8.5		1	123	3.92.4545.02
4545-02 (set)	42	45	8.5	3xFI	1	196	3.92.4545.02.SET

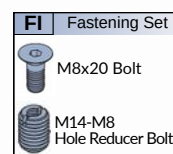
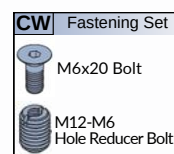
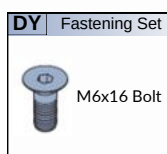

## ACCESORIOS DE PERFIL



End Cap

T slot Cover

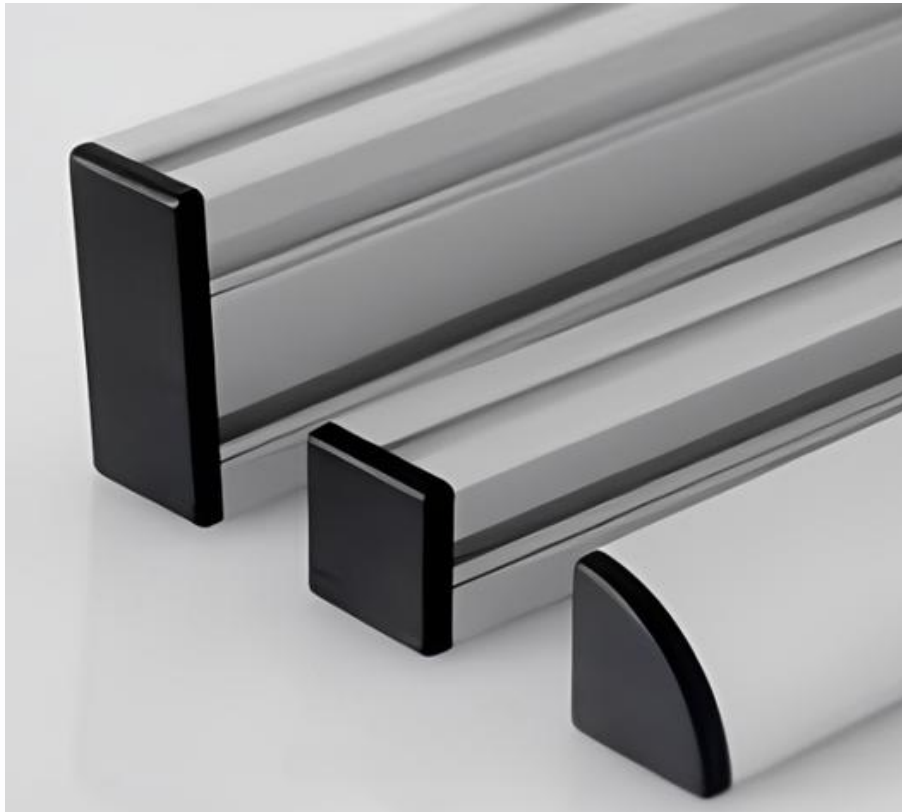

**Material:** Back ABS

Previene que el personal sufra alguna lesión y mejora la apariencia de las orillas del perfil.

---

To prevent staff from any injury and improve profile end appearance

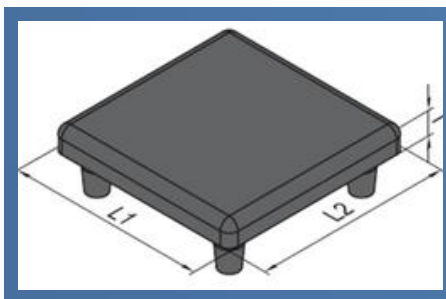
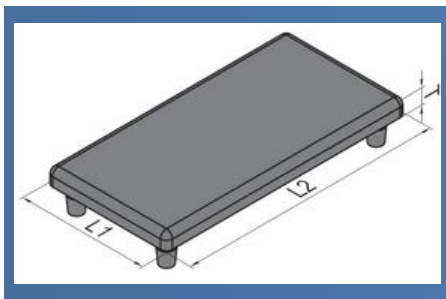

Description	L1 (mm)	L2 (mm)	T (mm)	Mass (g)	Part No.	
End Cap-PG15-1515	15	15	3	1	4.11.15.1515	
End Cap-PG15-1530	15	30	3	1.1	4.11.15.1530	
<b>End Cap-PG20-2020</b>	20	20	4	2	<b>4.11.20.2020</b>	Más vendido
<b>End Cap-PG20-2040</b>	20	40	4	3	<b>4.11.20.2040</b>	Más vendido
End Cap-PG20-2060	20	60	4	4	4.11.20.2060	
End Cap-PG20-2080	20	80	4	5	4.11.20.2080	
End Cap-PG20-4040	40	40	4	6	4.11.20.4040	
<b>End Cap-PG30-3030</b>	30	30	5	3	<b>4.11.30.3030</b>	Más vendido
<b>End Cap-PG30-3060</b>	30	60	5	8	<b>4.11.30.3060</b>	Más vendido
End Cap-PG30-3090	30	90	5	11	4.11.30.3090	
End Cap-PG30-30120	30	120	5	14	4.11.30.30120	
End Cap-PG30-6060	60	60	5	15	4.11.30.6060	
End Cap-PG30-60120	60	120	5	33	4.11.30.60120	
<b>End Cap-PG40-4040</b>	40	40	5	6	<b>4.11.40.4040</b>	Más vendido
End Cap-PG40-4060	40	60	5	9	4.11.40.4060	
<b>End Cap-PG40-4080</b>	40	80	5	13	<b>4.11.40.4080</b>	Más vendido
End Cap-PG40-40120	40	120	5	18	4.11.40.40120	
End Cap-PG40-40160	40	160	5	24	4.11.40.40160	
End Cap-PG40-8080	80	80	5	22	4.11.40.8080	
End Cap-PG40-80120	80	120	5	43	4.11.40.80120	
End Cap-PG40-80160	80	160	5	58	4.11.40.80160	
End Cap-PG40-80200	80	200	5	72	4.11.40.80200	
End Cap-PG40-120120	120	120	5	64	4.11.40.120120	
<b>End Cap-PG45-4545</b>	45	45	5	8	<b>4.11.45.4545</b>	Más vendido
End Cap-PG45-4560	45	60	5	11	4.11.45.4560	
End Cap-PG45-4590	45	90	5	16	4.11.45.4590	
<b>End Cap-PG45-9090</b>	90	90	5	28	<b>4.11.45.9090</b>	Más vendido
End Cap-PG45-90180	90	180	5	72	4.11.45.90180	
End Cap-PG50-5050	50	50	5	10	4.11.50.5050	
End Cap-PG50-50100	50	100	5	18	4.11.50.50100	
End Cap-PG50-100100	100	100	5	44	4.11.50.100100	
End Cap-PG60-6060	60	60	5	14	4.11.60.6060	

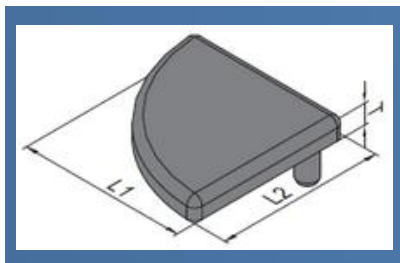

Description	L1 (mm)	L2 (mm)	T (mm)	Mass (g)	Part No.
End Cap-PG20-2020R	20	20	4	1	4.11.20.2020R
End Cap-PG30-3030R	30	30	5	3	4.11.30.3030R
End Cap-PG40-4040R	40	40	5	6	4.11.40.4040R
End Cap-PG45-4545R	45	45	5	7	4.11.45.4545R

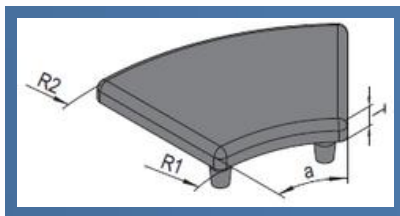

Description	R1 (mm)	R2 (mm)	a	T (mm)	Mass (g)	Part No.
End Cap-PG30-3030R45	30	60	45°	5	4	4.11.30.3030R45
End Cap-PG40-4040R45	40	80	45°	5	7	4.11.40.4040R45
End Cap-PG405-4545R45	45	90	45°	5	9	4.11.45.4545R45

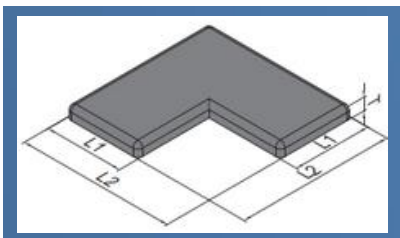

Description	L1 (mm)	L2 (mm)	T (mm)	Mass (g)	Part No.
End Cap-PG30-6060L	30	60	5	11	4.11.30.6060L
End Cap-PG40-8080L	40	80	5	17	4.11.40.8080L
End Cap-PG45-9090L	45	90	5	22	4.11.45.9090L

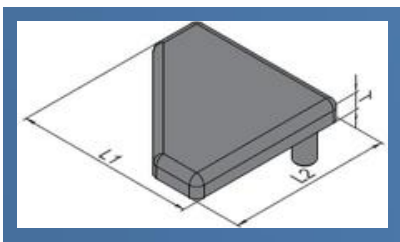

Description	L1 (mm)	L2 (mm)	T (mm)	Mass (g)	Part No.
End Cap-PG40-4040T	40	40	5	5.3	4.11.40.4040T

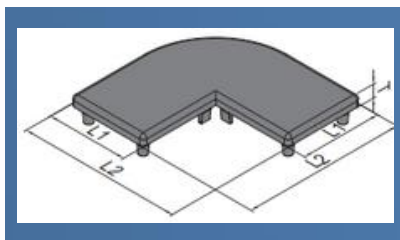

Description	L1 (mm)	L2 (mm)	T (mm)	Mass (g)	Part No.
End Cap-PG40-8080R	40	80	5	17	4.11.40.8080R

**Conduit Cap 40x40**

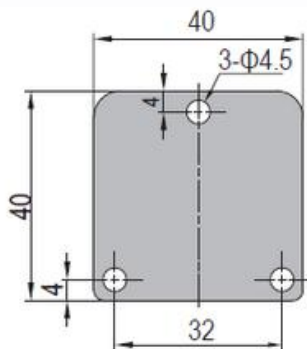

**Conduit Cap 40x80**

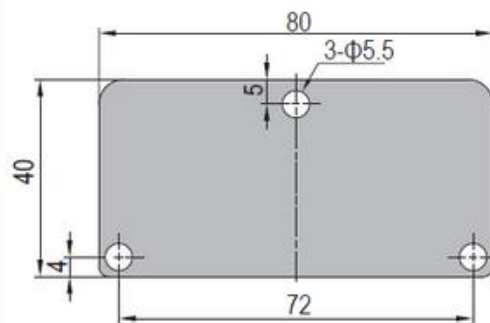

**Conduit Cap 60x120**

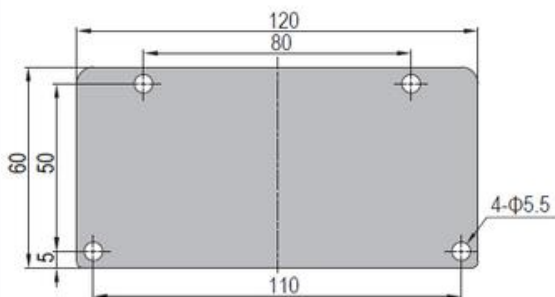

**Conduit Cap 80x80**

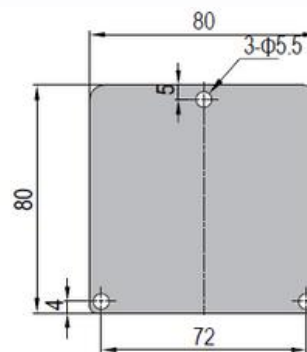

**Conduit Cap 80x160**

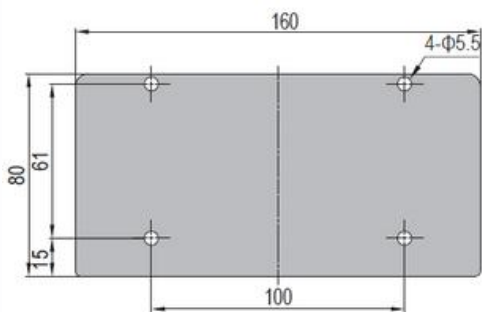

**Conduit Cap 80x200**

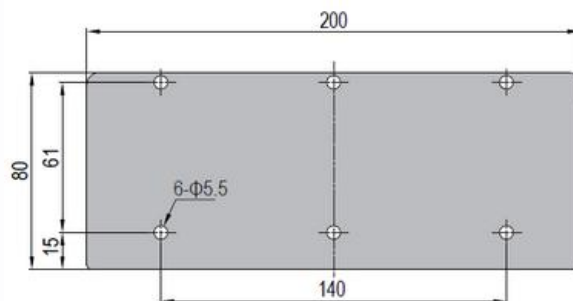

Description	Thickness T (mm)	Fastening Set	Mass (g)	Part No.
Cubic Connector-4545-2 (pcs)	2		24.5	4.14.40.4040
Cubic Connector-4545-2 (set)	2	3x <b>EU</b>	29	4.14.40.4040.SET
Cubic Connector-4545-2(pcs)	2		50	4.14.40.4080
Cubic Connector-4545-3 (set)	2	3x <b>EV</b>	59	4.14.40.4080.SET
Cubic Connector-4545-2 (pcs)	2		113	4.14.40.60120
Cubic Connector-4545-2 (set)	2	4x <b>EV</b>	125	4.14.40.60120.SET
Cubic Connector-4545-2 (pcs)	2		99	4.14.40.8080
Cubic Connector-4545-2 (set)	2	3x <b>EV</b>	108	4.14.40.8080.SET
Cubic Connector-4545-2 (pcs)	2		203	4.14.40.80160
Cubic Connector-4545-2 (set)	2	4x <b>EV</b>	215	4.14.40.80160.SET
Cubic Connector-4545-2 (pcs)	2		247	4.14.40.80200
Cubic Connector-4545-2 (set)	2	6x <b>EV</b>	265	4.14.40.80200.SET

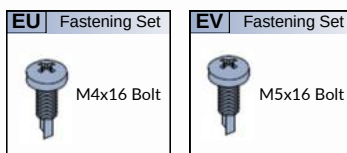

# T slot Cover

Accesorios de Perfil

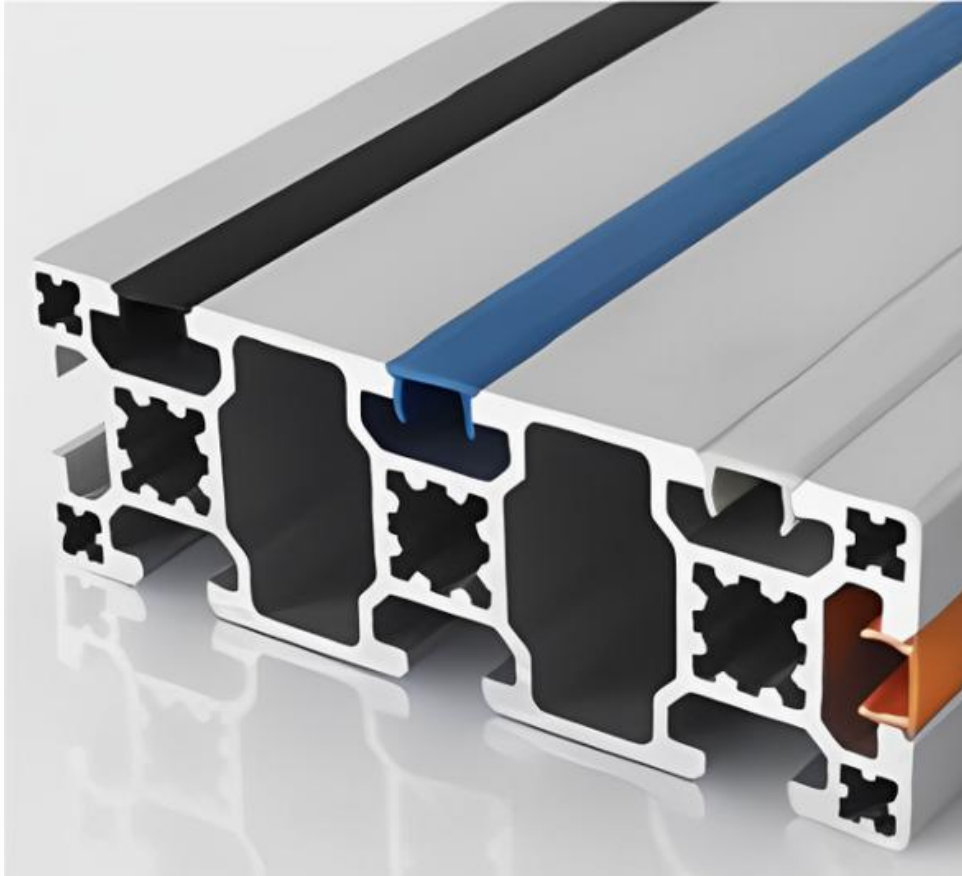

**Material:** PP Black/blue/grey/orange

Previene que la ranura se contamine y mejora la apariencia de las orillas del perfil.

---

To prevent slot from contamination and improve structure appearance

## T slot Cover-6

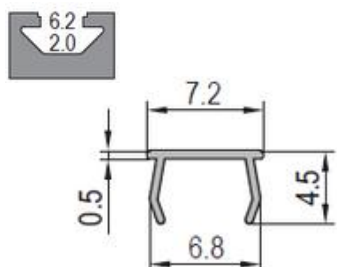

## T slot Cover-8

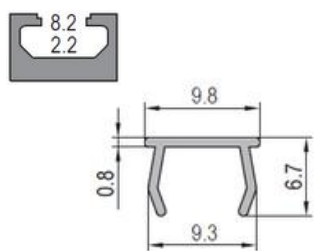

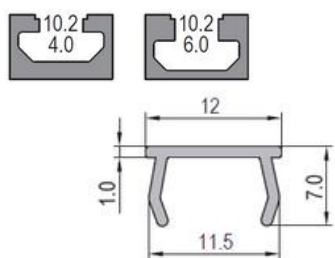

## T slot Cover-10

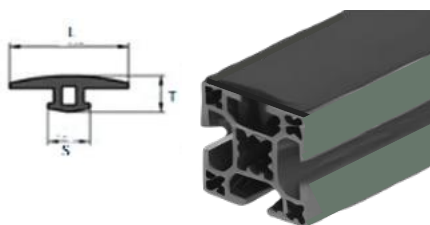

## Profile Cover 40x40



Description	Color	Mass (g)	Delivery Length	Part No.
T Slot Cover-6	Black	11	200mm/bar	4.21.06.BK
T Slot Cover-6	Blue	11		4.21.06.BE
T Slot Cover-6	Gray	11		4.21.06.GY
T Slot Cover-6	Orange	11		4.21.06.SE
<b>T Slot Cover-8</b>	Black	22		<b>4.02.08.BK</b> 
T Slot Cover-8	Blue	22		4.21.08.BE
<b>T Slot Cover-8</b>	Gray	22		<b>4.02.08.GY</b> 
T Slot Cover-8	Orange	22		4.21.08.SE
<b>T Slot Cover-8</b>	Black			<b>4.21.08.BK</b> 
<b>T Slot Cover-10</b>	Black	38		<b>4.21.10.BK</b> 
T Slot Cover-10	Blue	38		4.21.10.BE
<b>T Slot Cover-10</b>	Gray	38		<b>4.21.10.GY</b> 
T Slot Cover-10	Orange	38	4.21.10.SE	
<b>T Slot Cover-10</b>	Yellow	38	<b>4.21.10.YW</b> 	
<b>Profile Cover 40x40</b>	Black	38	100mm/bar	<b>40.4.02.05.01</b> 

# ELEMENTOS DE PISO



Base Plate  
Leveling Foot  
Mounting Plate  
Castor Plate  
Castor  
Base Angle  
L Base  
Foot and Castor Components  
Leveling Castor

# Base Plate

Elementos de Piso



**Material:** Cast steel, black electrophoresis

Para apoyar el perfil estructural en la base. Usa tornillos de expansión para atornillarse al suelo y ofrecer una mayor estabilidad.

To support strut profile at the bottom. Expansion bolts chocked into floor can offer a high stability.

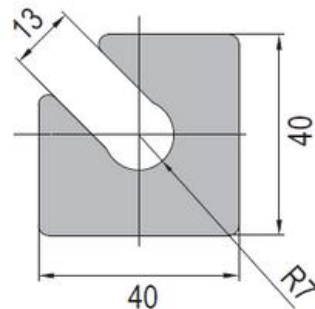
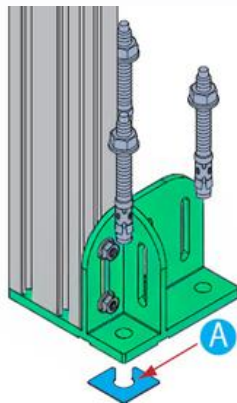

**Base Plate-4080**

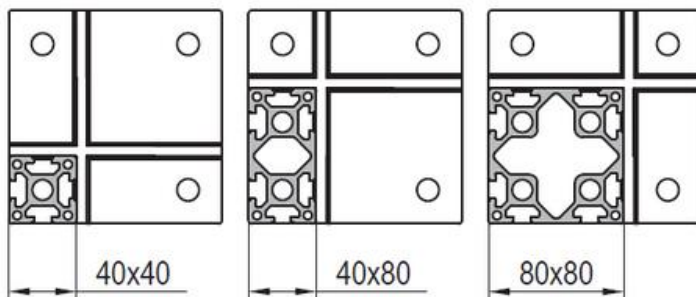
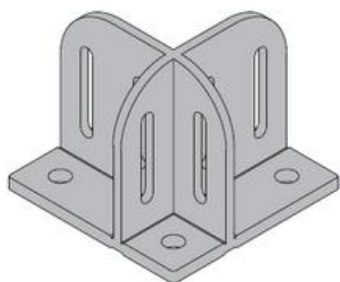

**Base Plate-4560**

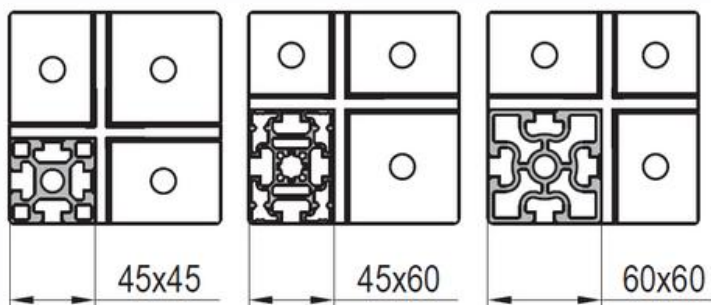
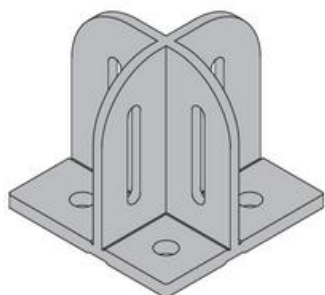

**Base Plate-4590**

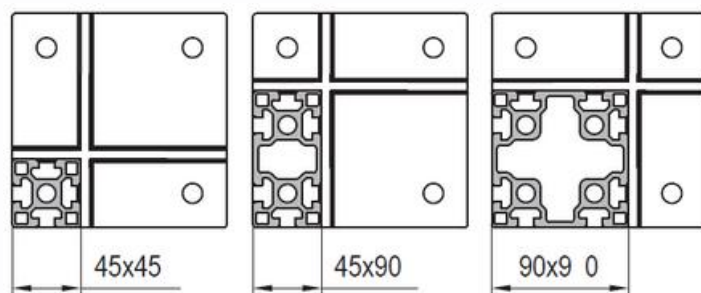
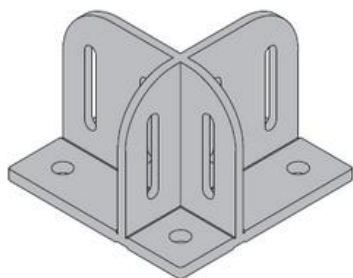

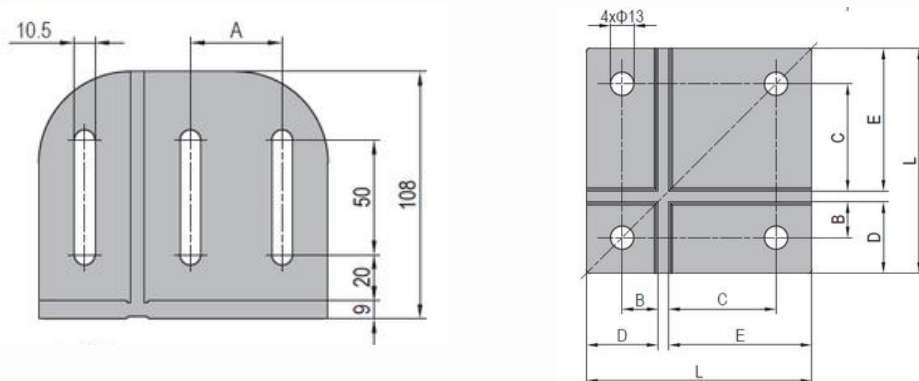

Description	L (mm)	A (mm)	B (mm)	C (mm)	D (mm)	E (mm)	Fastening Set	Mass (g)	Part No.
Base Plate-4080 (pcs)	126	40	20	60	40	80	2x <b>AZ</b>	1930	5.11.4080
Base Plate-4080 (set A)	126	40	20	60	40	80	4xC+3xAA+2x <b>AZ</b>	2240	5.11.4080.SETA
Base Plate-4080 (set B)	126	40	20	60	40	80	6xC+3xAA+2x <b>AZ</b>	2290	5.11.4080.SETB
Base Plate-4080 (set C)	126	40	20	60	40	80	8xC+3xAA+2x <b>AZ</b>	2340	5.11.4080.SETC
Base Plate-4560 (pcs)	111		22.5	30	45	60	2x <b>AZ</b>	1600	5.11.4560
Base Plate-4560 (set)	111		22.5	30	45	60	4xC+3xAA+2x <b>AZ</b>	1910	5.11.4560.SET
Base Plate-4590 (pcs)	141	45	22.5	67.5	45	90	2x <b>AZ</b>	2330	5.11.4590
Base Plate-4590 (set A)	141	45	22.5	67.5	45	90	4xC+3xAA+2x <b>AZ</b>	2640	5.11.4590.SETA
Base Plate-4590 (set B)	141	45	22.5	67.5	45	90	6xC+3xAA+2x <b>AZ</b>	2690	5.11.4590.SETB
Base Plate-4590 (set C)	141	45	22.5	67.5	45	90	8xC+3xAA+2x <b>AZ</b>	2740	5.11.4590.SETC
Base Plate Gasket								9	5.11.01

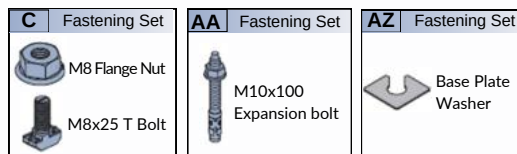

# Base Plate

Elementos de Piso



**Material:** Cast steel, black electrophoresis

Para apoyar el perfil estructural montado en el piso o entre plataformas. Usa tornillos de expansión para atornillarse al suelo y ofrecer una mayor estabilidad.

---

To support strut profile mounted on the floor or between the platforms. Expansion bolts chocked into floor can offer a high stability.

## Base Plate-4080

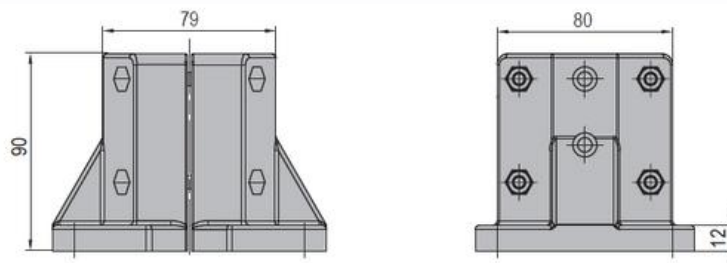

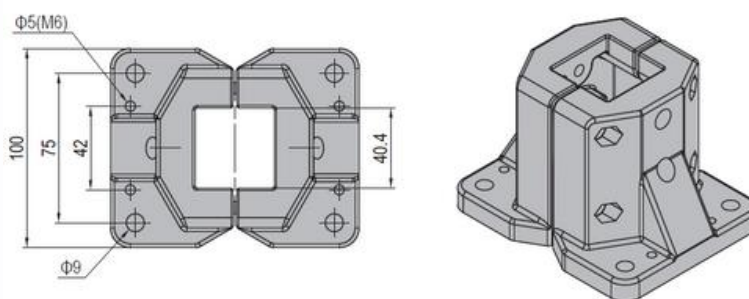

## Base Plate-4560

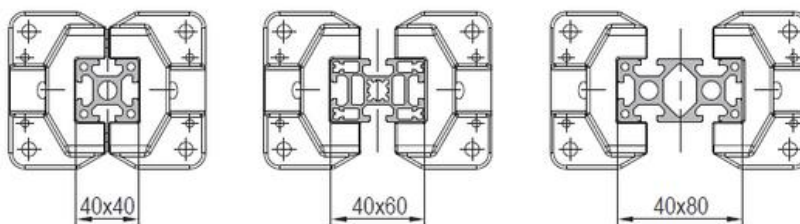

## Base Plate-4590



Description	Fastening Set	Mass (g)	Part No.
Base Plate-4080 (set)	4xDT	975	5.12.40.SET

DT	Fastening Set
	M6x20 Bolt
	M6 Spring Washer
	M6 Pre-set Nut

# Leveling Foot/ Pivot Foot

## Elementos de Piso

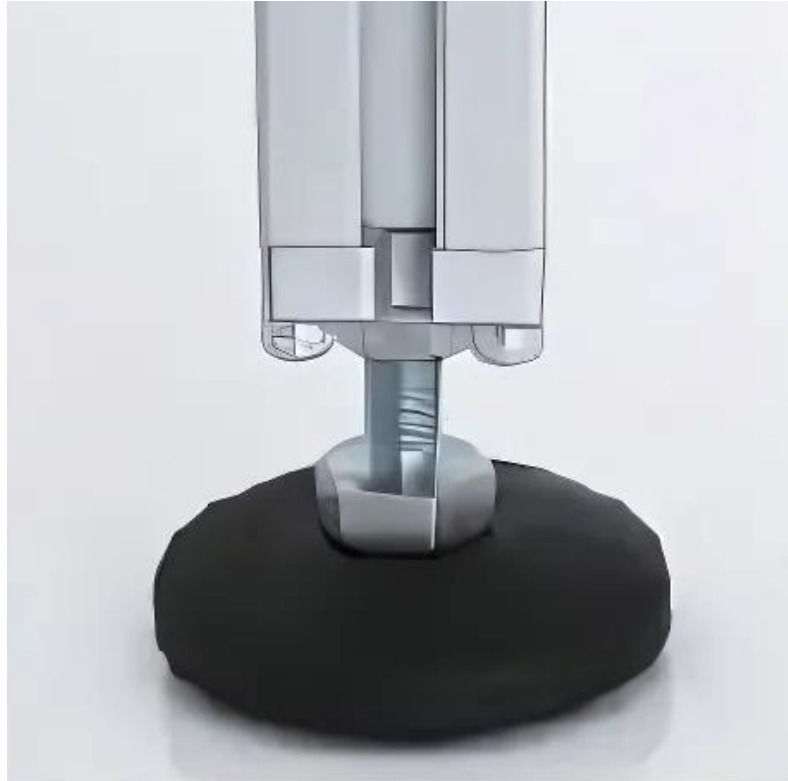

**Material:** Base-black PA6  
Spindle- Zinc plated steel  
Pad- Black rubber

Para apoyar estructuras donde requerirá ajustes graduales de altura, el pie con pivote tiene un pequeño ángulo para arreglar la altura en pisos desnivelados. La conexión entre la base del pivote y la tuerca puede ser liberada con herramienta

To support structure where gradual height adjustment is needed, the pivot foot has a small swiveling angle to fit slightly uneven floor. The connection between the pivot base and the spindle can be released with a tool.

## Pivot Foot

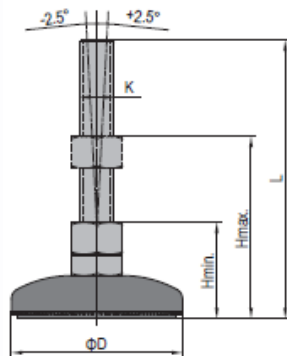

Description	D (mm)	KxL (mm)	H min. (mm)	H max. (mm)	Max. Static Load (N)	Mass (g)	Part No.
Pivot Foot-PA 6 Base	59	M12x90	45	70	4500	152	5.21.60.12.90
Pivot Foot-PA 6 Base	59	M14x130	45	100	7000	220	5.21.60.14.130
Pivot Foot-PA 6 Base	79	M12x90	45	70	9000	188	5.21.80.12.90
Pivot Foot-PA 6 Base	79	M12x130	45	100	9000	218	5.21.80.12.130
Pivot Foot-PA 6 Base	79	M16x130	45	100	9000	328	5.21.80.16.130
Pivot Foot-PA 6 Base	99	M12x130	45	100	10000	326	5.21.100.12.130
Pivot Foot-PA 6 Base	99	M16x130	45	100	10000	436	5.21.100.16.130

# Leveling Foot/ Swivel Foot

## Elementos de Piso



**Material:** Base-black PA6  
Spindle- Zinc plated steel  
Pad- Black rubber

Para apoyar estructuras donde requerirá ajustes graduales de altura, el pie girador tiene una bola entre la base y el eje, permitiéndole a la pata girarse a un ángulo hasta de 30°. Es aplicable para componentes que se mueven frecuentemente

---

To support structure where gradual height adjustment is needed, the swivel foot has a ball joint between the base and spindle, thus allowing the foot to swivel to an angle up to 30°. It is suitable to be used on the components moved frequently.

## Swivel Foot

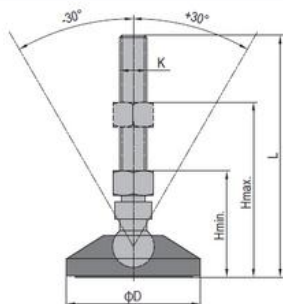

Description	D (mm)	KxL (mm)	H min. (mm)	H max. (mm)	Max. Static Load (N)	Mass (g)	Part No.
Swivel Foot-PA 6 Base	59	M12x90	45	70	4500	152	5.22.60.12.90
Swivel Foot-PA 6 Base	59	M12x130	45	70	9000	220	5.22.80.12.90
Swivel Foot-PA 6 Base	79	M12x130	45	100	9000	188	5.22.80.12.130
Swivel Foot-PA 6 Base	79	M16x130	45	100	9000	218	5.22.80.16.130
Swivel Foot-PA 6 Base	79	M12x130	45	100	10000	328	5.22.100.12.130
Swivel Foot-PA 6 Base	99	M16x130	45	100	10000	326	5.22.100.16.130
Swivel Foot-PA 6 Base	80	M12x100					30.4.05.1.80.12.100

## Leveling Foot/ Swivel Foot with holes

Elementos de Piso

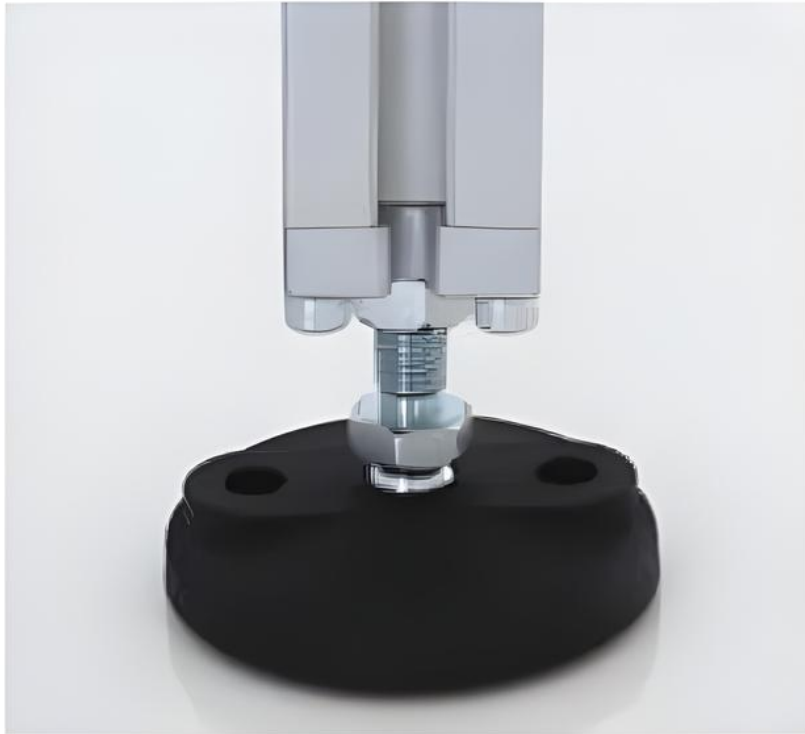

**Material:** Base-black PA6  
Spindle- Zinc plated steel  
Pad- Black rubber

Para apoyar estructuras donde requerirá ajustes graduales de altura, el pie girador tiene una bola entre la base y el eje, permitiéndole a la pata girarse a un ángulo hasta de 30°. Es recomendada para superficies desiguales.

---

To support structure where gradual height adjustment is needed, the swivel foot has a ball joint between the base and spindle, thus allowing the foot to swivel to an angle up to 30°. It is suitable for uneven surface and fixed with expansion bolts.

## Swivel Foot with holes

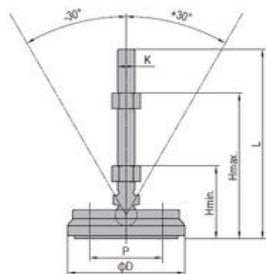

Description	D (mm)	P (mm)	KxL (mm)	H min. (mm)	H max. (mm)	Max. Static Load (N)	Fastening Set	Mass (g)	Part No.
Swivel Foot with holes-PA 6 Base (pcs)	80	50	M12x130	45	100	9000		217	5.22.80.12.130.DH
Swivel Foot with holes-PA 6 Base (set)	80	50	M12x130	45	100	9000	2x <b>DN</b>	291	5.22.80.12.130.DH.SET
Swivel Foot with holes-PA 6 Base (pcs)	80	50	M16x130	45	100	9000		297	5.22.80.16.130.DH
Swivel Foot with holes-PA 6 Base (set)	80	50	M16x130	45	100	9000	2x <b>DN</b>	317	5.22.80.16.130.DH.SET

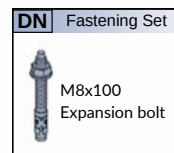

## Leveling Foot/ Fixed Foot

Elementos de Piso

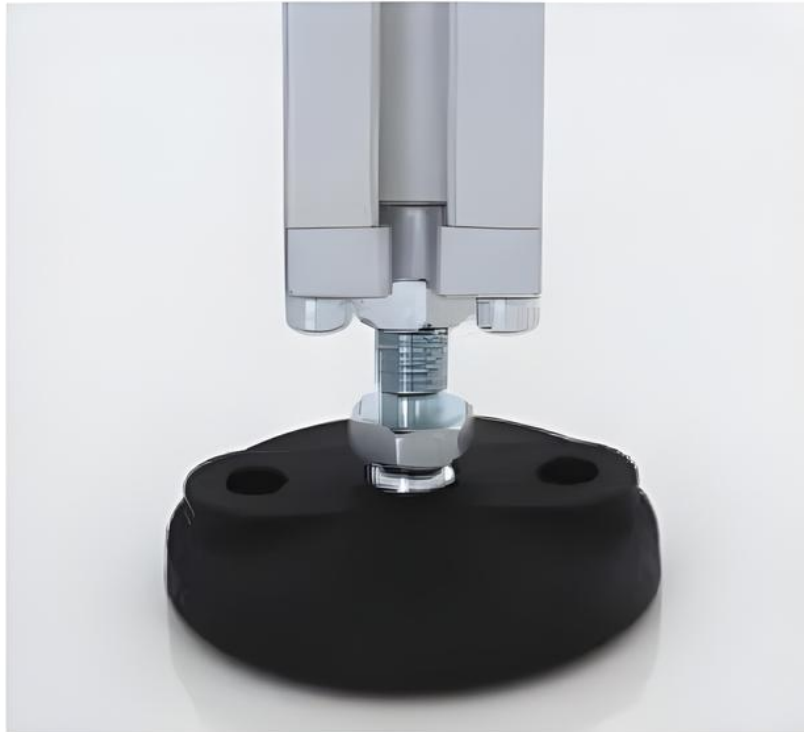

**Material:** Base-black PA6  
Spindle- Zinc plated steel  
Pad- Black rubber

La pata de nivelación tiene una conexión inmóvil entre la base y el tornillo

---

Fixed foot have a non-moving connection between base and spindle

## Fixed Foot

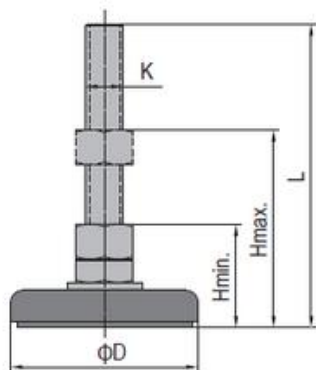

Description	D (mm)	KxL (mm)	H min. (mm)	H max. (mm)	Max. Static Load (N)	Mass (g)	Part No.
Fixed Foot- Steel Base	40	M12x70	35	50	4000	124	5.23.40.12.70
Fixed Foot- Steel Base	60	M12x70	35	50	7000	181	5.23.60.12.70
Fixed Foot- Steel Base	60	M14x70	38	50	7000	225	5.23.60.14.70
Fixed Foot- Steel Base	80	M12x70	35	50	9000	220	5.23.80.12.70
Fixed Foot- Steel Base	80	M12x110	35	80	9000	240	5.23.80.12.110
Fixed Foot- Steel Base	80	M14x70	38	50	9000	283	5.23.80.14.70

Ad: M14 Fixed Foot should use an end cap with a punched hole

# Leveling Foot/ Pivot Foot

## Elementos de Piso



**Material:** Zinc plated steel/ stainless steel

Para apoyar estructuras donde requerirá ajustes graduales de altura, el pie con pivote tiene un pequeño ángulo para arreglar la altura en pisos desnivelados. La conexión entre la base del pivote y la tuerca puede ser liberada con herramienta

---

To support structure where gradual height adjustment is needed, the pivot foot has a small swiveling angle to fit slightly uneven floor. The connection between the pivot base and the spindle can be released with a tool.

# Pivot Foot

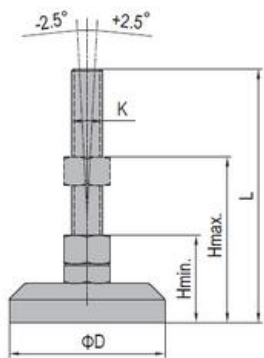

Description	D (mm)	KxL (mm)	H min. (mm)	H max. (mm)	Max. Static Load (N)	Mass (g)	Part No.
<b>Pivot Foot-Zinc Plate Steel</b>	40	M12x128	45	100	15000	241	<b>5.24.40.12.130</b>
Pivot Foot-Zinc Plate Steel	40	M14x128	45	100	17000	290	5.24.40.14.130
Pivot Foot-Zinc Plate Steel	60	M12x128	45	100	15000	475	5.24.60.12.130
Pivot Foot-Zinc Plate Steel	80	M14x128	45	100	17000	523	5.24.60.14.130
Pivot Foot-Zinc Plate Steel	60	M16x158	45	120	20000	596	5.24.60.16.160
Pivot Foot-Zinc Plate Steel	60	M20x178	50	130	25000	796	5.24.60.20.180
Pivot Foot-Zinc Plate Steel	80	M12x128	45	100	15000	670	5.24.80.12.130
Pivot Foot-Zinc Plate Steel	80	M16x158	45	120	20000	780	5.24.80.16.160
Pivot Foot-Zinc Plate Steel	80	M20x178	50	130	25000	945	5.24.80.20.180
Pivot Foot- Stainless Steel	40	M12x128	45	100	15000	240	5.24.40.12.130.SS
Pivot Foot- Stainless Steel	60	M12x128	45	100	15000	480	5.24.60.12.130.SS
Pivot Foot- Stainless Steel	60	M16x158	45	120	20000	600	5.24.60.16.160.SS
Pivot Foot- Stainless Steel	60	M20x178	50	130	25000	803	5.24.60.20.180.SS
Pivot Foot- Stainless Steel	80	M12x128	45	100	15000	675	5.24.80.12.130.SS
Pivot Foot- Stainless Steel	80	M16x158	45	120	20000	785	5.24.80.16.160.SS
Pivot Foot- Stainless Steel	80	M20x178	50	130	25000	950	5.24.80.20.180.SS
Leveling Pivot Foot	50	M12x100					40.4.05.1.50.12.100
Leveling Foot	60	M12X60					40.4.05.2.60.12.60



# Cup Pivot Foot

Elementos de Piso



**Material:** Zinc plated steel

Para apoyar estructuras donde requerirá ajustes graduales de altura, el pie con pivote tiene un pequeño ángulo para arreglar la altura en pisos desnivelados. La conexión entre la base del pivote y la tuerca puede ser liberada con herramienta

---

To support structure where gradual height adjustment is needed, the pivot foot has a small swiveling angle to fit slightly uneven floor. The connection between the pivot base and the spindle can be released with a tool.

## Cup Pivot Foot

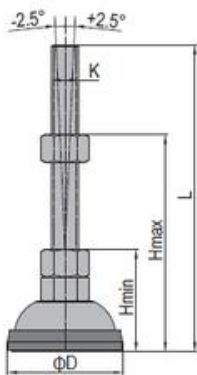

Description	D (mm)	KxL (mm)	H min. (mm)	H max. (mm)	Max. Static Load (N)	Mass (g)	Part No.
Cup Pivot Foot	45	M12x132	50	105	10000	148	5.25.40.12.130
<b>Cup Pivot Foot</b>	50	M12x132	50	105	10000	207	<b>5.25.45.12.130</b>



# Mounting Plate

Elementos de Piso



**Material:** Diecast aluminum

Usado para unir la pata niveladora o rueda a la punta del perfil estructural

To attach leveling foot or castor to strut profile end, but it does not apply for connecting of castors

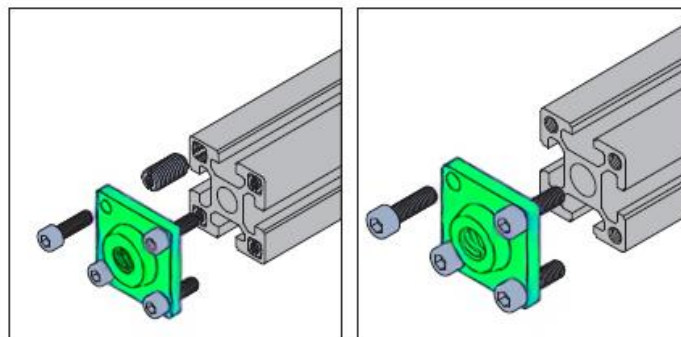

**PG40-4040 PG45-4545  
PG50-5050**

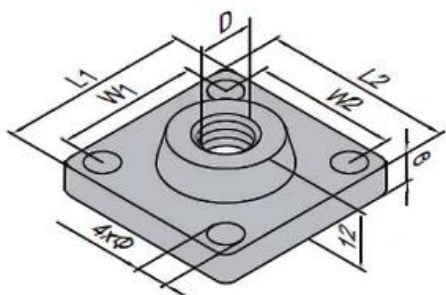

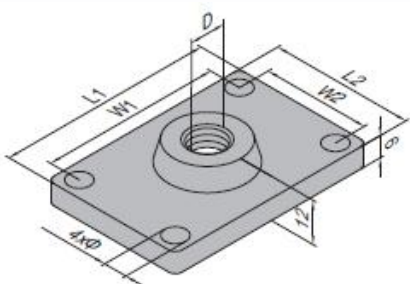

**PG40-4060 PG45-4560**

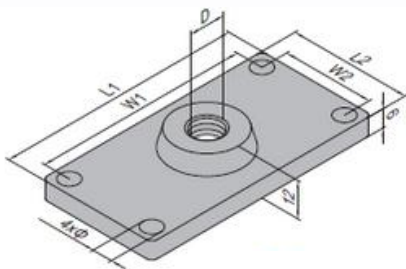

**PG40-4080 PG45-4590**



Description	D	Ø	L1 (mm)	L2 (mm)	W1 (mm)	W2 (mm)	Fastening Set	Mass (g)	Part No.
Mounting Plate-PG40-4040	M12	6.5	40	40	30	30	4x(M6x20)	51	5.31.40.4040
Mounting Plate-PG45-4545	M12	6.5	45	45	33	33	4xFC	97	5.31.45.4545
Mounting Plate-PG50-5050	M12	6.5	50	50	35	35	4x(M8x30)	130	5.31.50.5050
Mounting Plate-PG40-4060	M12	6.5	60	40	50	30	4x(M6x20)	67	5.31.40.4060
Mounting Plate-PG45-4560	M12	6.5	60	45	48	33	4xFC	108	5.31.45.4560
Mounting Plate-PG40-4080	M12	6.5	80	40	70	30	4x(M6x20)	78	5.31.40.4080.M12
	M16						4x(M6x20)	78	5.31.40.4080.M16
Mounting Plate-PG45-4590	M12	6.5	90	45	78	33	4xFC	131	5.31.45.4590.M12
	M16						4xFC	128	5.31.45.4590.M16

FC	Fastening Set
	M6x20 Bolt
	M10-M6 Hole Reducer Bolt



**Material:** Spray coating steel

Usado para unir la pata niveladora o rueda a la punta del perfil estructural

To attach leveling foot or castor to strut profile end

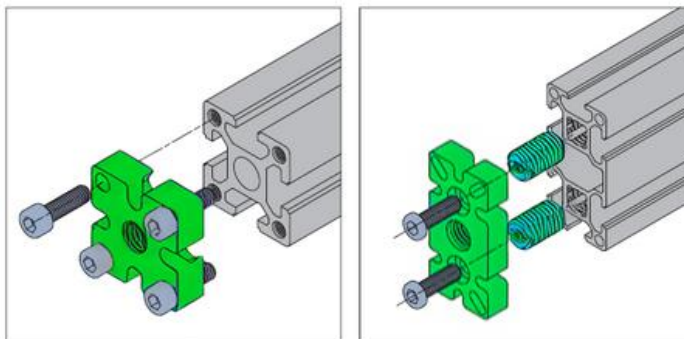

**PG40-4040 PG45-4545  
PG50-5050**

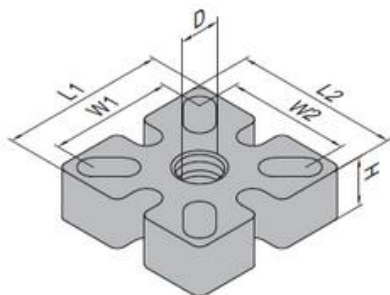



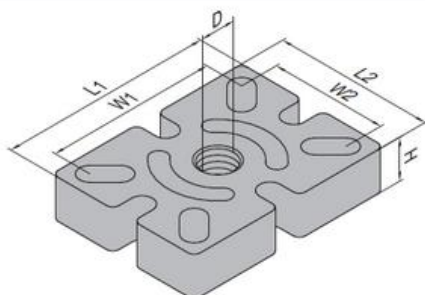

**PG40-4060 PG45-4560**

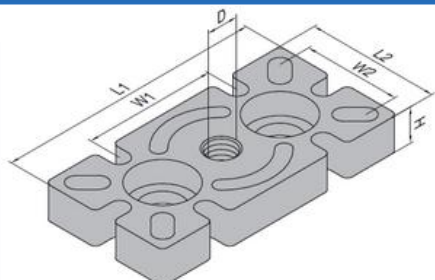

Description	D (mm)	L1 (mm)	L2 (mm)	W1 (mm)	W2 (mm)	H (mm)	Fastening Set	Mass (g)	Part No.
Mounting Plate-PG40-4040	M12	40	40	30	30	12	4x(M6x20)	128	5.32.4040
Mounting Plate-PG45-4545	M12	45	45	33	33	12	4xFI	203	5.32.45.4545
Mounting Plate-PG50-5050	M12	50	50	35	35	12	4x(M8x20)	218	5.32.50.5050
Mounting Plate-PG40-4060	M12	60	40	50	30	12	4x(M6x20)	176	5.32.40.4060
Mounting Plate-PG45-4560	M12	60	45	48	33	12	4xFI	220	5.32.45.4560
Mounting Plate-PG30-3060	M12	60	30	30	23	10	2xFZ	133	5.32.30.3060
Mounting Plate-PG40-4080	M12	80	40	40	30	12	2x(M14x25)	272	5.32.40.4080.M12
	M16							270	5.32.40.4080.M16
Mounting Plate-PG45-4590	M12	90	45	45	33	12	2x(M14x25)	332	5.32.45.4590.M12
	M16							330	5.32.45.4590.M16
Mounting Plate-PG50-50100	M12	100	50	50	35	12	2x(M14x25)	332	5.32.50.50100.M12
	M16							329	5.32.50.50100.M16
	M20							327	5.32.50.50100.M20

**PG30-3060 PG40-4080  
PG45-4590 PG50-50100**



<b>FI</b> Fastening Set	<b>FZ</b> Fastening Set
 M6x25 Bolt	 M6x20 Bolt
 M10-M6 Hole Reducer Bolt	 M12-M6 Hole Reducer Bolt

**PG30-6060 PG40-8080  
PG45-9090 PG50-100100  
PG60-6060**

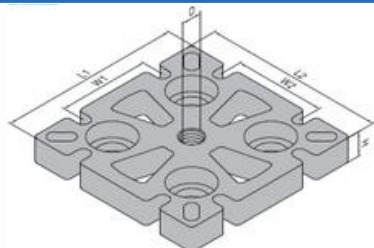

**PG30-3030  
PG30-3060**

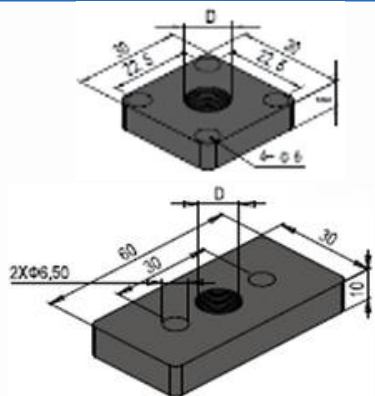



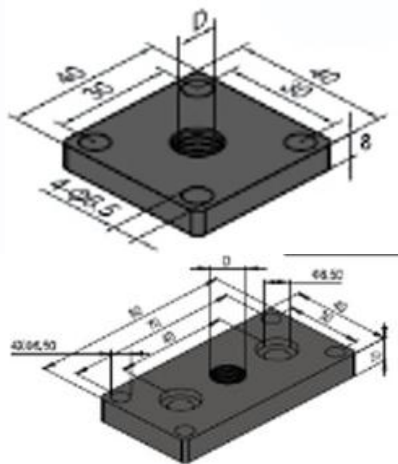

**PG40-4040  
PG40-4080**

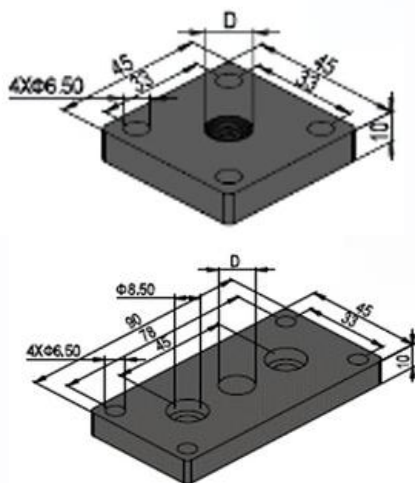

**PG45-4545  
PG45-4590**



Description	D (mm)	L1 (mm)	L2 (mm)	W1 (mm)	W2 (mm)	H (mm)	Fastening Set	Mass (g)	Part No.
Mounting Plate-PG30-6060	M12	60	60	30	30	10	4x <b>FZ</b>	232	5.32.30.6060.M12
	M16	60	60	30	30	10	4x <b>FZ</b>	230	5.32.30.6060.M16
Mounting Plate-PG40-8080	M12	80	80	40	40	12	4x <b>(M14x25)</b>	534	5.32.40.8080.M12
	M16	80	80	40	40	12	4x <b>(M14x25)</b>	532	5.32.40.8080.M16
Mounting Plate-PG45-9090	M12	80	80	40	40	12	4x <b>(M14x25)</b>	530	5.32.40.8080.M20
	M20	80	80	40	40	12	4x <b>(M14x25)</b>	530	5.32.40.8080.M20
Mounting Plate-PG50-100100	M12	90	90	45	45	12	4x <b>(M14x25)</b>	664	5.32.45.9090.M12
	M16	90	90	45	45	12	4x <b>(M14x25)</b>	661	5.32.45.9090.M16
	M20	90	90	45	45	12	4x <b>(M14x25)</b>	659	5.32.45.9090.M20
Mounting Plate-PG60-100100	M12	100	100	50	50	12	4x <b>(M14x25)</b>	725	5.32.50.100100.M12
	M16	100	100	50	50	12	4x <b>(M14x25)</b>	722	5.32.50.100100.M16
	M20	100	100	50	50	12	4x <b>(M14x25)</b>	720	5.32.50.100100.M20
Mounting Plate-PG60-6060	M12	60	60	40	40	10	4x <b>FY</b>	330	5.32.60.6060
Mounting Plate PG30-3030	M12						4x <b>Y</b>	74	30.4.07.1.3030.12.02
Mounting Plate PG30-3060	M12						4x <b>Y</b>	123	30.4.07.1.3060.12.02
Mounting Plate PG40-4040	M12						4x <b>Y</b>	123	40.4.07.1.4040.12.02
Mounting Plate PG40-4080	M12						4x <b>Y</b>	123	40.4.07.1.4080.12.02
Mounting Plate PG45-4545	M12						4x <b>Y</b>	153	45.4.07.1.4545.12.02
Mounting Plate PG45-4590	M12						4x <b>Y</b>	232	45.4.07.1.4590.12.02

<b>FY</b> Fastening Set	<b>FZ</b> Fastening Set
 M8x20 Bolt	 M6x20 Bolt
 M16-M8 Hole Reducer Bolt	 M12-M6 Hole Reducer Bolt

# Mounting Plate

Elementos de Piso



**Material:** Die Cast Zinc

Usado para unir la pata niveladora o rueda a la punta del perfil estructural

To attach leveling foot or castor to strut profile end

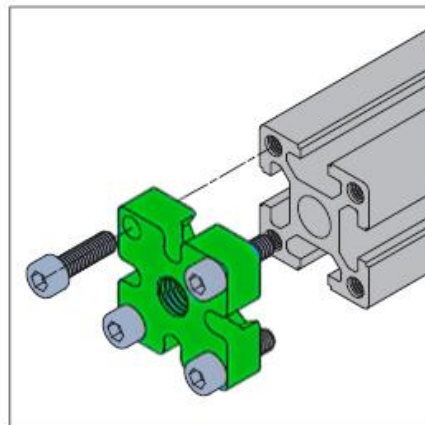

**PG40-4040 PG45-4545**

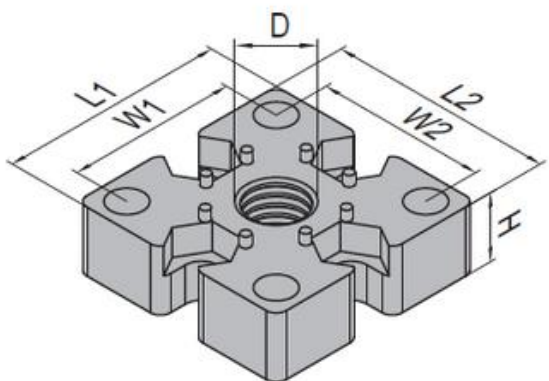

Description	D (mm)	L1 (mm)	L2 (mm)	W1 (mm)	W2 (mm)	H (mm)	Fastening Set	Mass (g)	Part No.
Mounting Plate-PG40-4040	M12	40	40	30	30	12	4x(M6x20)	117	5.33.40.4040
Mounting Plate-PG45-4545	M12	45	45	33	33	12	4xFC	189	5.33.45.4545
Mounting Plate-PG40-4080	M12	80	40	40		12	2x(M14x25)	277	5.33.40.4080.M12
	M16	80	40	40		12	2x(M14x25)	275	5.33.40.4080.M16
Mounting Plate-PG45-4590	M12	90	45	45		12	2x(M14x25)	344	5.33.45.4590.M12
	M16	90	45	45		12	2x(M14x25)	342	5.33.45.4590.M16
Mounting Plate-PG40-8080	M12	80	80	40	40	12	4x(M14x25)	582	5.33.40.8080.M12
	M16	80	80	40	40	12	4x(M14x25)	580	5.33.40.8080.M16
	M20	80	80	40	40	12	4x(M14x25)	577	5.33.40.8080.M20
Mounting Plate-PG45-9090	M12	90	90	45	45	12	4x(M14x25)	714	5.33.45.9090.M12
	M16	90	90	45	45	12	4x(M14x25)	714	5.33.45.9090.M16
	M20	90	90	45	45	12	4xFY	709	5.33.45.9090.M20

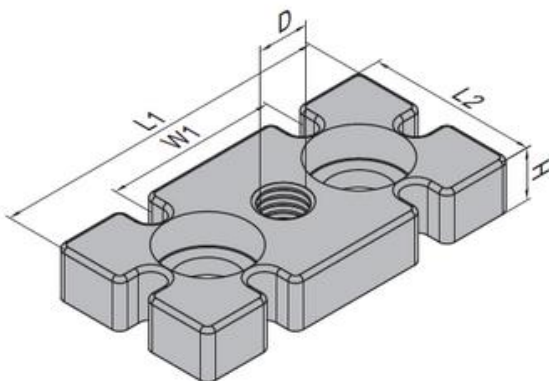

**PG40-4080 G45-4590**

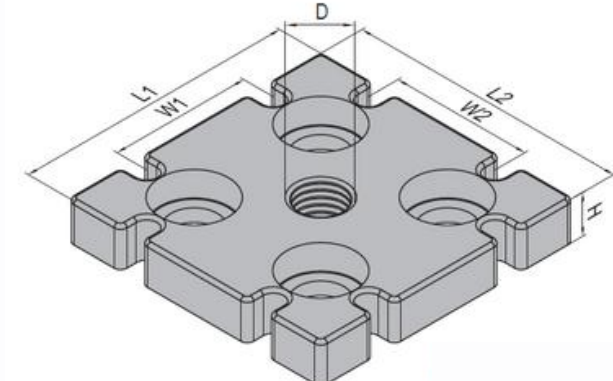

**PG40-8080 PG45-9090**



**FC** Fastening Set

-  M6x20 Bolt
-  M10-M6 Hole Reducer Bolt

# Mounting Plate

Elementos de Piso



**Material:** Steel  
**Color:** Negro

Usado para unir la pata niveladora o rueda a la punta del perfil estructural

To attach leveling foot or castor to strut profile end

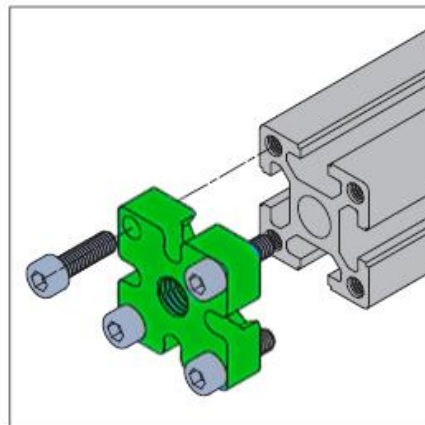

### PG30

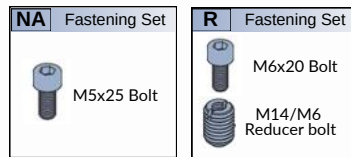
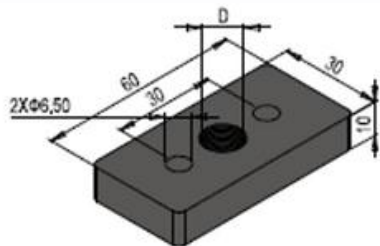

### PG40

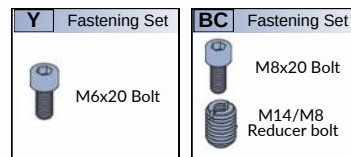
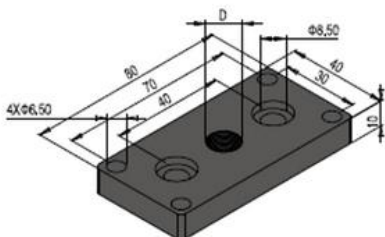

### PG45

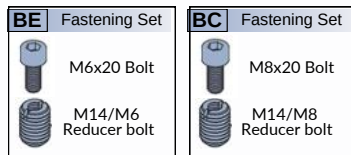
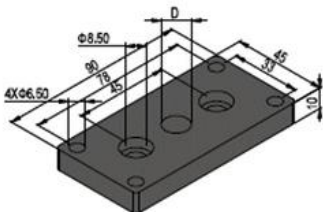

Description	Fastener	D (mm)	NW (g)	Part No.
3030 Plate	2xNA	M12	74	30.4.07.1.3030.12.02
3060 Plate	2xR	M12	123	30.4.07.1.3060.12.02
6060 Plate	4xR	M12	300	30.4.07.1.6060.12.02
4040 Plate	4xY	M14	105	40.4.07.1.4040.12.02
4080 Plate	4xY	M12	162	40.4.07.1.4080.12.02
8080 Plate	4xBC	M16	492	40.4.07.1.8080.12.02
4545 Plate	4xBE	M14	153	45.4.07.1.4545.12.02
4590 Plate	4xBE	M12	232	45.4.07.1.4590.12.02
9090 Plate	4xBC	M16	606	45.4.07.1.9090.16.02



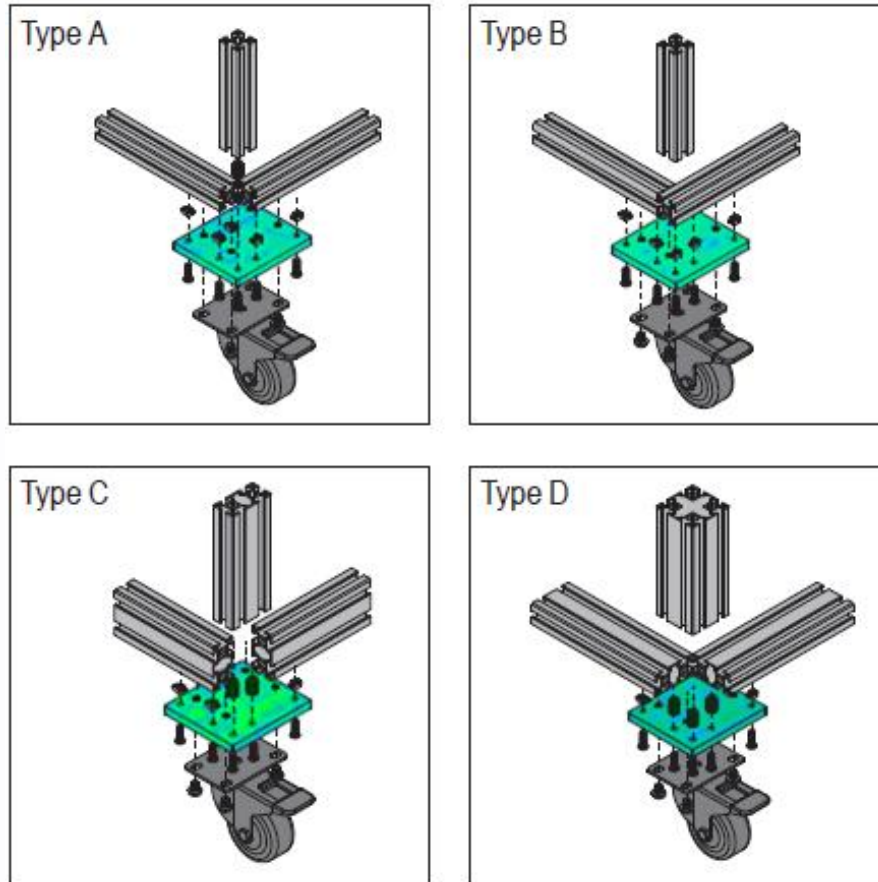

**Material:** Zinc plated steel

La base de la rueda es usada para unir los perfiles a la llanta







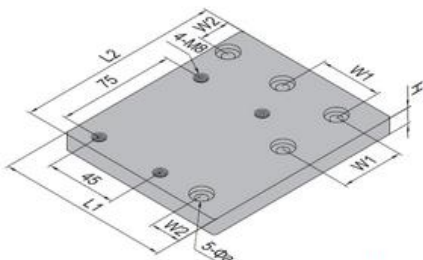





---

The castor plate is used for attaching profiles to the castor with plate

**PG40-4040 PG45-4545**



Description	PG	H (mm)	L1 (mm)	L2 (mm)	W1 (mm)	W2 (mm)	Øa (mm)	Fastening Set	Mass (g)	Part No.
Castor Plate A-PG30	PG30	10	105	120	30	15	7	4xGL+1xGM+4xAM	1056	5.34.30.SETA
Castor Plate B-PG30	PG30	10	105	120	30	15	7	5xGL+4xAM	1049	5.34.30.SETB
Castor Plate C-PG30	PG30	10	105	120	30	15	7	3xGL+2xGM+4xAM	1063	5.34.30.SETC
Castor Plate D-PG30	PG30	10	105	120	30	15	7	2xGL+3xGM+4xAM	1070	5.34.30.SETD
Castor Plate A-PG40	PG40	12	110	130	40	20	9	4xGJ+1xGN+4xAM	1229	5.34.40.SETA
Castor Plate B-PG40	PG40	12	110	130	40	20	9	5xGJ+4xAM	1222	5.34.40.SETB
Castor Plate C-PG40	PG40	12	110	130	40	20	9	3xGJ+2xGN+4xAM	1236	5.34.40.SETC
Castor Plate D-PG40	PG40	12	110	130	40	20	9	2xGJ+2xGN+4xAM	1243	5.34.40.SETD
Castor Plate A-PG45	PG45	12	120	130	45	22.5	9	4xGK+1xGN+4xAM	1237	5.34.45.SETA
Castor Plate B-PG45	PG45	12	120	130	45	22.5	9	5xGK+4xAM	1230	5.34.45.SETB
Castor Plate C-PG45	PG45	12	120	130	45	22.5	9	3xGK+2xGN+4xAM	1244	5.34.45.SETC
Castor Plate D-PG45	PG45	12	120	130	45	22.5	9	2xGK+3xGN+4xAM	1251	5.34.45.SETD

CJ	Fastening Set	GK	Fastening Set	GL	Fastening Set	GM	Fastening Set
	M8x20 Bolt		M8x25 Bolt		M6x16 Bolt		M6x20 Bolt
	M8 Spring Washer		M8 Spring Washer		M6 Spring Washer		M6 Spring Washer
	M8 T Nut		M8 T Nut		M6 T Nut		M12-M6 Hole Reducer Bolt

# Castor Plate-Heavy

Elementos de Piso

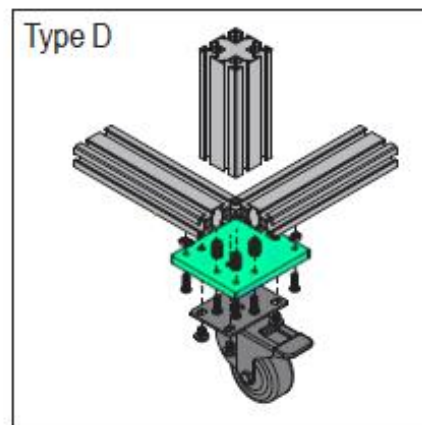
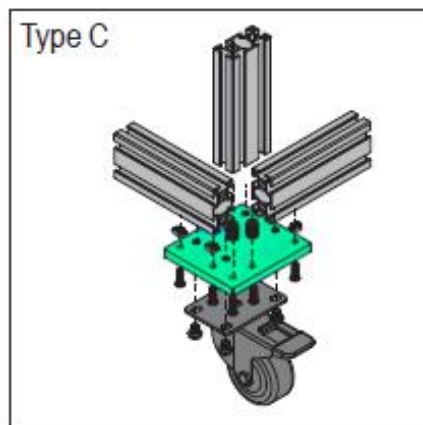
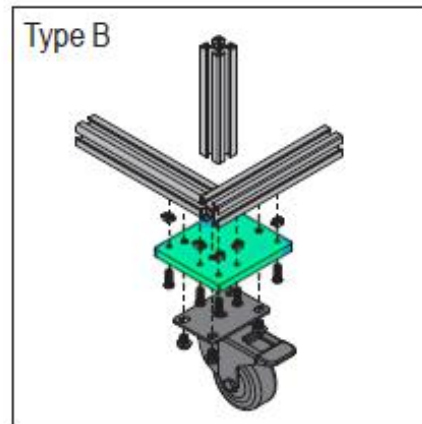
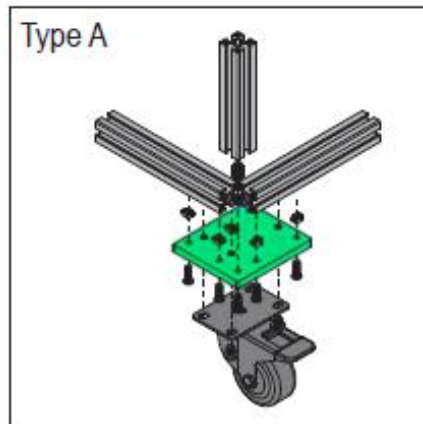



**Material:** Zinc plated steel

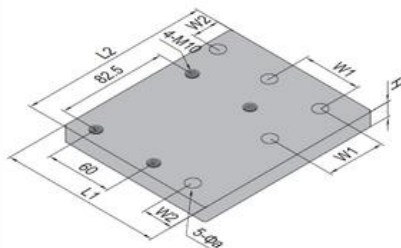

La base de rueda es usada para unir los perfiles a la llanta con una base de uso pesado

The castor plate is used for attaching profiles to the castor with plate-Heavy











Description	PG	H (mm)	L1 (mm)	L2 (mm)	W1 (mm)	W2 (mm)	Øa (mm)	Fastening Set	Mass (g)	Part No.
Castor Plate-Heavy A-PG30	PG30	10	105	135	30	15	7	4xDO+1xDQ+4xDS	1364	5.34.30.H.SETA
Castor Plate-Heavy B-PG30	PG30	10	105	135	30	15	7	5xDO+4xDS	1356	5.34.30.H.SETB
Castor Plate-Heavy C-PG30	PG30	10	105	135	30	15	7	3xDO+2xDQ+4xDS	1372	5.34.30.H.SETC
Castor Plate-Heavy D-PG30	PG30	10	105	135	30	15	7	2xDO+4xDS	1380	5.34.30.H.SETD
Castor Plate-Heavy A-PG40	PG40	12	110	145	40	20	9	4xDP+1xDR+4xDS	1834	5.34.40.H.SETA
Castor Plate-Heavy B-PG40	PG40	12	110	145	40	20	9	5xDP+4xDS	1826	5.34.40.H.SETB
Castor Plate-Heavy C-PG40	PG40	12	110	145	40	20	9	3xDP+2xDR+4xDS	1842	5.34.40.H.SETC
Castor Plate-Heavy D-PG40	PG40	12	110	145	40	20	9	2xDP+3xDR+4xDS	1850	5.34.40.H.SETD
Castor Plate-Heavy A-PG45	PG45	12	120	145	45	22.5	9	4xDP+1xDR+4xDS	1969	5.34.45.H.SETA
Castor Plate-Heavy B-PG45	PG45	12	120	145	45	22.5	9	5xDP+4xDS	1972	5.34.45.H.SETB
Castor Plate-Heavy C-PG45	PG45	12	120	145	45	22.5	9	3xDP+2xDR+4xDS	1977	5.34.45.H.SETC
Castor Plate-Heavy D-PG45	PG45	12	120	145	45	22.5	9	2xDP+3xDR+4xDS	1985	5.34.45.H.SETD

DO	Fastening Set
	M6x20 Bolt
	M6 Spring Washer
	M6 Washer
	M6 T Nut

DQ	Fastening Set
	M6x20 Bolt
	M6 Spring Washer
	M6 Washer
	M12-M6 Hole Reducer Bolt

DS	Fastening Set
	M10x16 Bolt
	M10 Washer

DP	Fastening Set
	M8x25 Bolt
	M8 Spring Washer
	M8 Washer
	M8 T Nut

DR	Fastening Set
	M8x25 Bolt
	M8 Spring Washer
	M8 Washer
	M14-M8 Hole Reducer Bolt

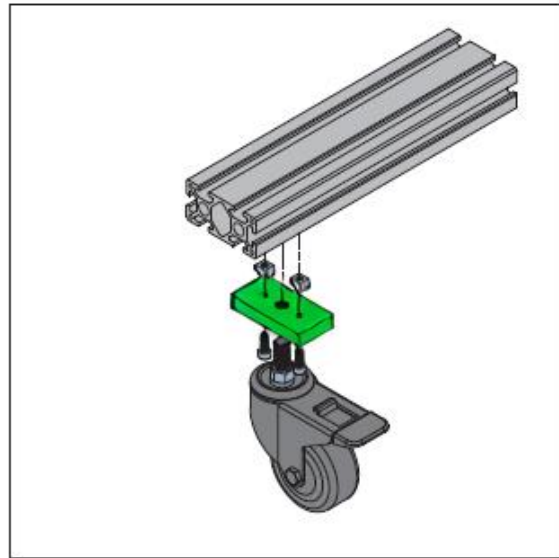
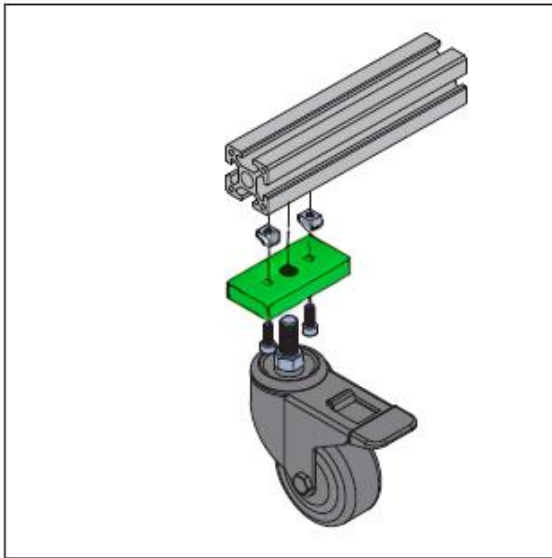

**Material:** Zinc plated steel

La base de la rueda es usada para unir los perfiles a la llanta con hilo

The castor plate is used for attaching profiles to the castor with thread

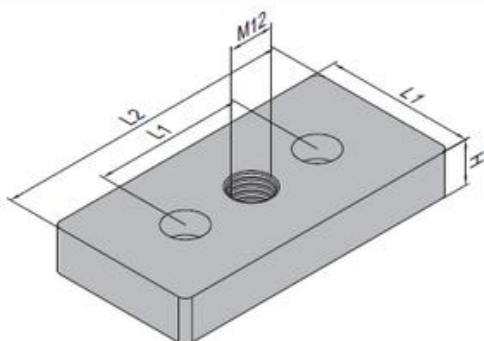

Description	PG	H (mm)	L1 (mm)	L2 (mm)	Fastening Set	Mass (g)	Part No.
Castor Plate-PG30	PG30	10	30	60	2x <b>FS</b>	162	5.35.30.SET
Castor Plate-PG40	PG40	12	40	80	2x <b>CQ</b>	296	5.35.40.SET
Castor Plate-PG45	PG45	12	45	90	2x <b>CQ</b>	377	5.35.45.SET

When the castor is installed with this castor plate, the profile need to be machined with a  $\varnothing 12.5$  and 20mm depth hole at the corresponding position to the thread of the castor.

<b>FS</b>	Fastening Set	<b>CQ</b>	Fastening Set
	M6x10 Bolt		M6x16 Bolt
	M6 T Nut		M6 T Nut

# Castor

Elementos de Piso



**Material:** Base- Carbon steel, plastic powder coated  
Wheel- Polyurethane (Heavy duty- Nylon)

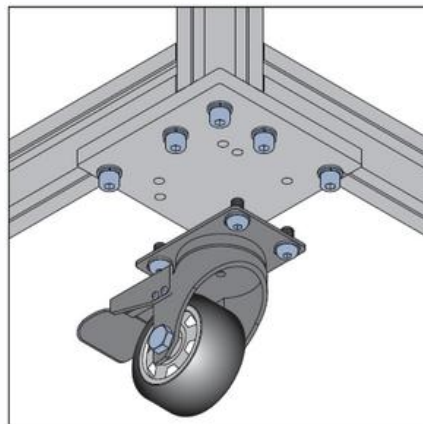

### Thread- Universal

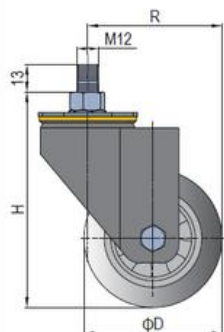

### Thread-Break-Universal

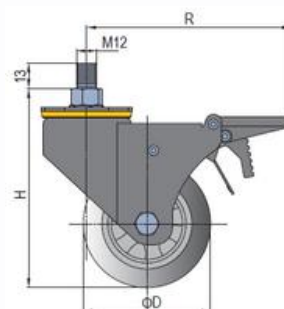

### Plate-Universal-Heavy

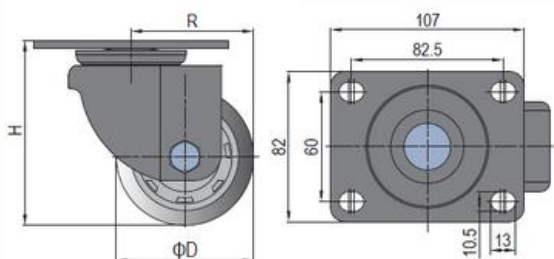

### Plate-Universal

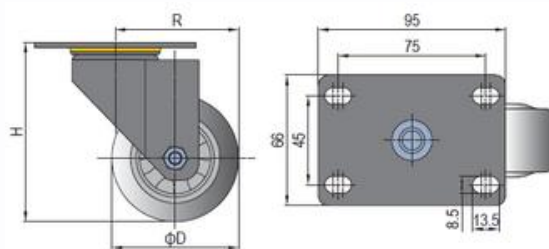

### Plate-Fixed-Heavy

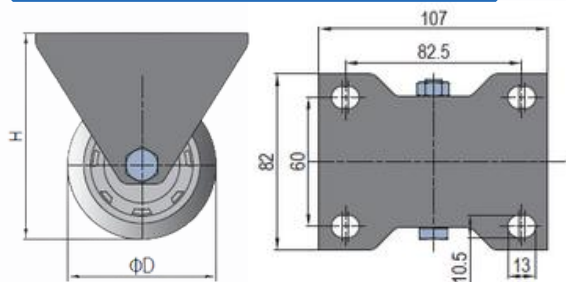

### Plate-Fixed

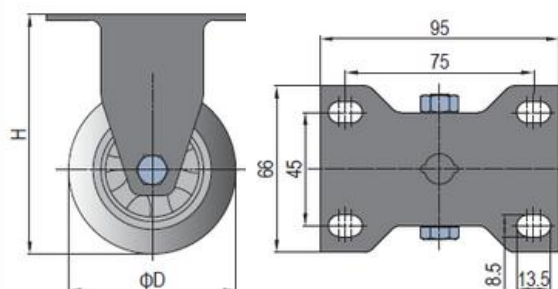

# Plate-Brake

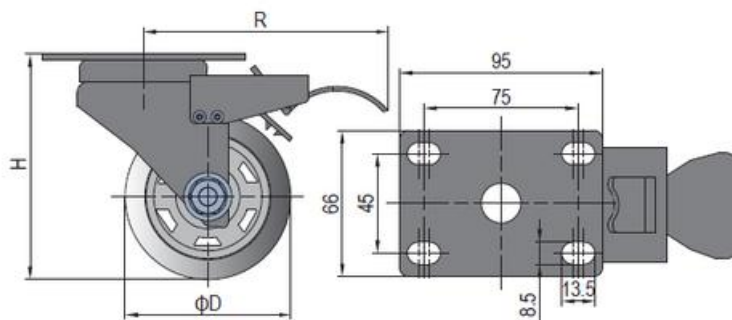

Description	Wheel Width (mm)	D (mm)	R (mm)	H (mm)	Load (N)	Mass (g)	Part No.
<b>Castor-Thread-Universal</b>	32	63	63	104	800	500	<b>5.41.63.M12</b>
	32	75	73	119	1050	670	5.41.75.M12
	32	100	87	142	1350	790	<b>5.41.100.M12</b>
<b>Castor-Thread-Brake-Universal</b>	32	63	112	104	800	650	<b>5.41.63.M12B</b>
	32	75	112	119	1050	770	40.4.06.2.2.75.1
	32	100	122	142	1350	930	<b>5.41.100.M12B</b>
Castor-Plate- Universal	32	63	63	92	800	570	5.41.63U
	32	75	73	107	1050	690	5.41.75U
	32	100	87	130	1350	870	5.41.100U
Castor-Plate- Fixed	32	63		92	800	370	5.41.63F
	32	75		107	1050	490	5.41.75F
	32	100		130	1350	670	5.41.100F
Castor-Plate-Brake	32	63	118	92	800	670	5.41.63B
	32	75	118	107	1050	790	5.41.75B
	32	100	127	130	1350	970	5.41.100B
Castor-Plate- Universal-Heavy	50	75	65	104	6000	1150	5.41.75UH
Castor-Plate- Fixed-Heavy	50	75		104	6000	950	5.41.75FH
Castor- Thread		50					40.4.06.2.2.50.2



# Base Angle

Elementos de Piso

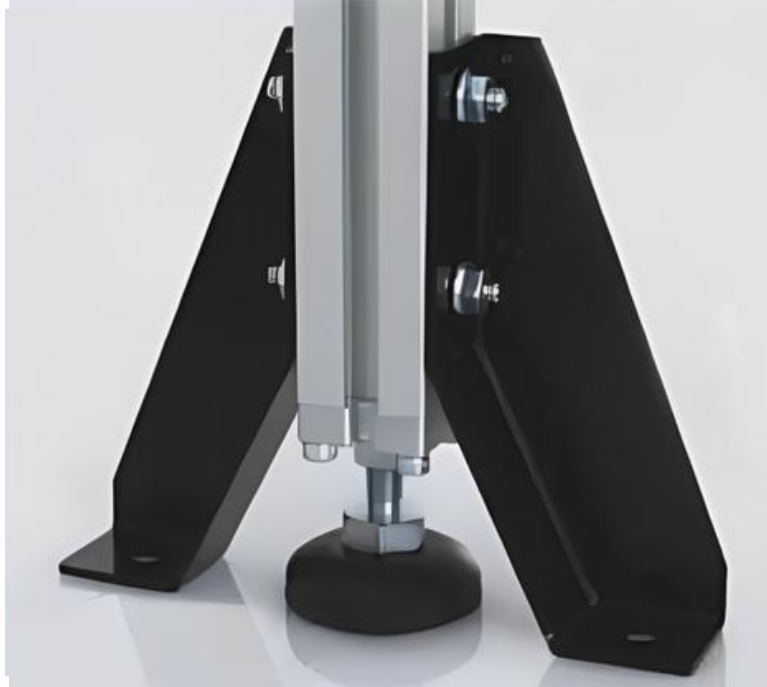

**Material:** Steel, black electrophoresis

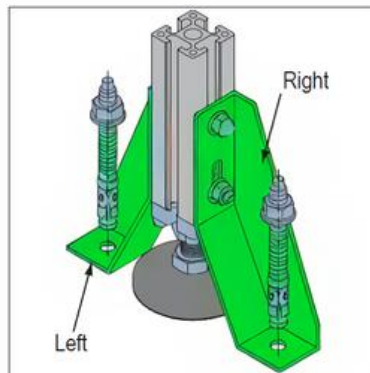

Mejora la estabilidad de una estructura apoyada con pata niveladora

To improve stability of structure supported by leveling foot

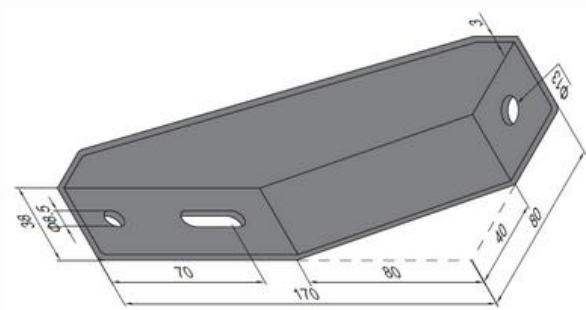



Description	Fastening Set	Mass (g)	Part No.
Base Angle-Left (pcs)		346	5.51.L
Base Angle-Left (set)	2x <b>C</b> +1x <b>AA</b>	473	5.51.L.SET
Base Angle-Right (pcs)		346	5.51.R
Base Angle-Right (set)	2x <b>C</b> +1x <b>AA</b>	473	5.51.R.SET
Base Angle-L+R (pair)		692	5.51.P
Base Angle-L+R (set)	4x <b>C</b> +2x <b>AA</b>	946	5.51.P.SET

<b>C</b> Fastening Set	<b>AA</b> Fastening Set
 M8 Flange Nut	 M10x100 Expansion bolt
 M8x20 T Bolt	

# L Base

Elementos de Piso



**Material:** Diecast aluminum black electrophoresis





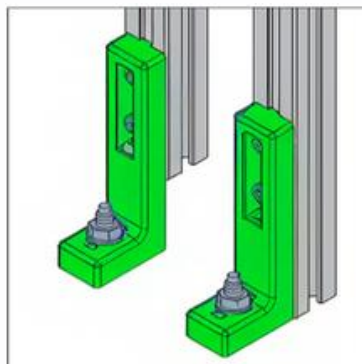

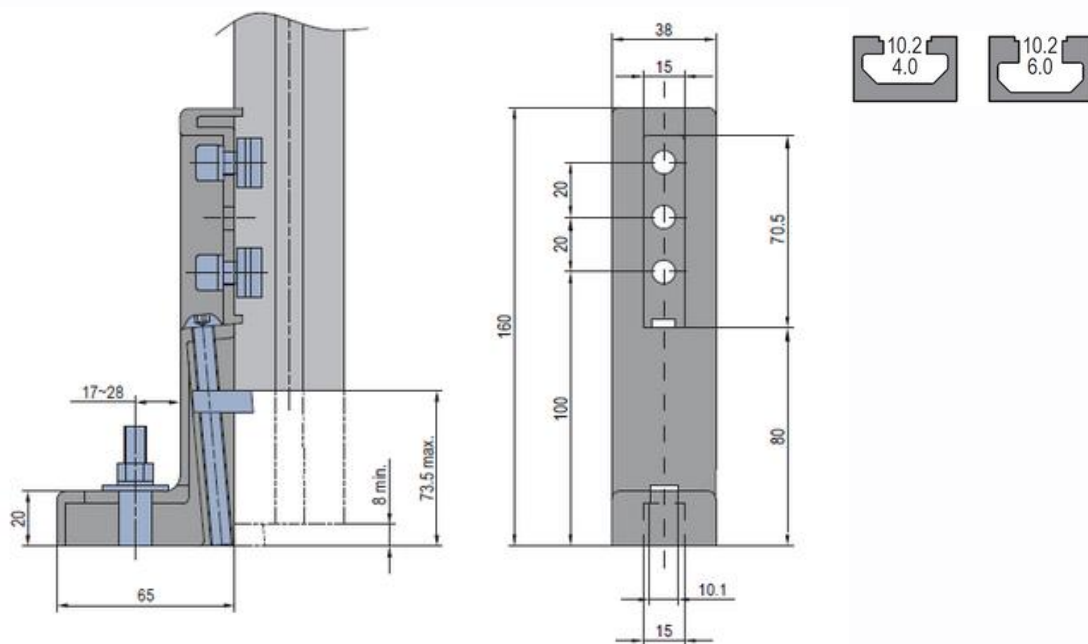
La base en L es para atornillar el perfil al piso, ajustando a la altura deseada

L base is to fix the profile on the floor and adjust the height of the profile to the floor





Description	Fastening Set	Mass (g)	Part No.
L Base (pcs)		276	5.52.10
L Base-PG40 (set)	2x <b>DI</b> +1x <b>DN</b>	343	5.52.10.04.ST
L Base-PG45 (set)	2x <b>DM</b> +1x <b>DN</b>	346	5.52.10.06.ST

<b>DI</b> Fastening Set  M8x16 Bolt  M8 Spring Washer  M8 Pre-set Nut	<b>DM</b> Fastening Set  M8x20 Bolt  M8 Spring Washer  M8 Pre-set Nut	<b>DN</b> Fastening Set  M10x100 Expansion bolt
---	---	---



**LIGHT**

**Material:** Foot- Steel black electrophoresis  
Wheel- Polyurethane  
Plate- Diecast aluminum

**HEAVY:**

**Material:** Foot- Zinc plated steel  
Wheel- PA  
Plate- Cast steel

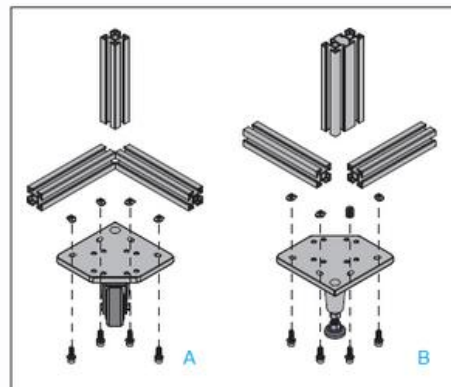



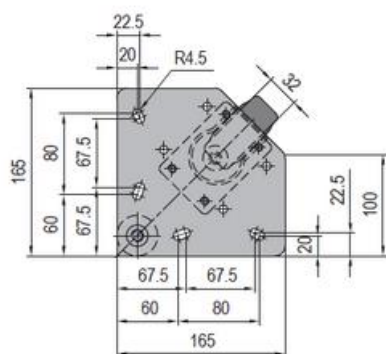
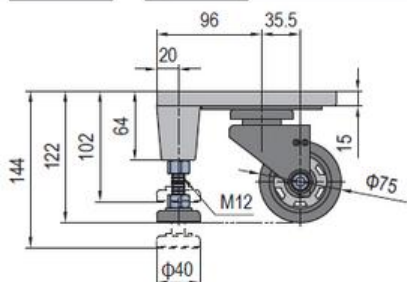

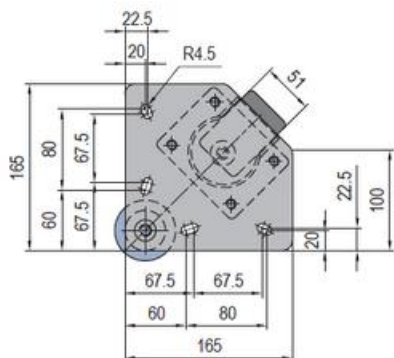
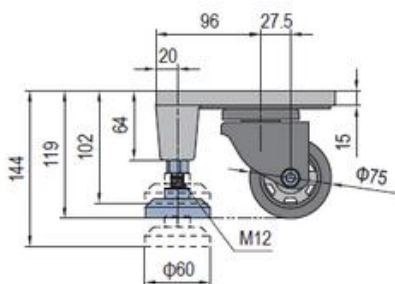

## Light











## Heavy







Description	Fastening Set	Load (N)	Mass (g)	Part No.
<b>Light Weight (pcs)</b>		1050	3900	5.61.L
Light Weight (set)	4x <b>J</b>	1050	3950	<b>5.61.40.L.SETA</b> 
	3x <b>J</b> +1x <b>AF</b>	1050	3950	<b>5.61.40.L.SETB</b> 
	4x <b>W</b>	1050	3950	5.61.45.L.SETA
	3x <b>W</b> +1x <b>AG</b>	1050	3950	5.61.45.L.SETB
<b>Heavy Weight (pcs)</b>		6000	4600	5.61.H
Heavy Weight (set)	4x <b>J</b>	6000	4650	5.61.40.H.SETA
	3x <b>J</b> +1x <b>AF</b>	6000	4650	5.61.40.H.SETB
	4x <b>W</b>	6000	4650	5.61.45.H.SETA
	3x <b>W</b> +1x <b>AG</b>	6000	4650	5.61.45.H.SETB

<b>AF</b>	Fastening Set
	M8x25 Bolt
	M8 Spring Washer
	M8 Washer
	M14-M8 Hole Reducer Bolt

<b>AG</b>	Fastening Set
	M8x30 Bolt
	M8 Spring Washer
	M8 Washer
	M14-M8 Hole Reducer Bolt

<b>J</b>	Fastening Set
	M8x25 Bolt
	M8 Spring Washer
	M8 Washer
	M8 T Nut

<b>W</b>	Fastening Set
	M8x30 Bolt
	M8 Spring Washer
	M8 Washer
	M8 T Nut

# Leveling Castor

Elementos de Piso



**Material:** Base- Carbon steel  
Case- Aluminum  
Wheel- Nylon 6

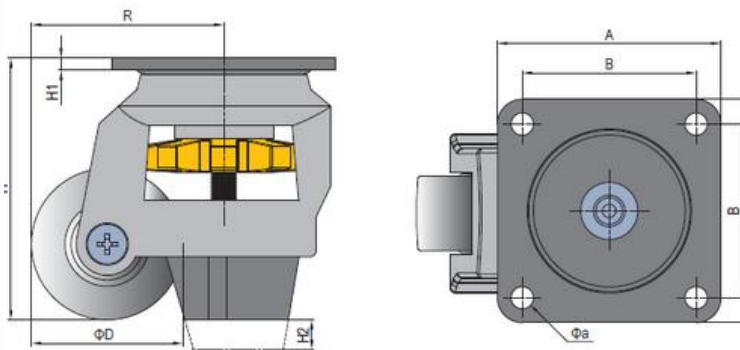

Description	Wheel Width (mm)	D (mm)	R (mm)	H (mm)	H (mm)	H (mm)	A (mm)	B (mm)	a (mm)	Load (g)	Mass (g)	Part No.
Leveling Castor	22	50	62	83	4	10	73	58	7	1700	0.69	5.62.60F
	29	62	77	102	5	12	90	70	9.5	3400	1.31	5.62.80F
	31	72	91	121	6	15	95	70	11.5	6700	1.75	5.62.120F



# ELEMENTOS DE INSTALACIÓN DE PANELES



T Slot Reducing Profile  
Panel Mounting Block  
Panel Mounting Strip  
Mounting Block

# T Slot Reducing Profile

Elementos de Instalación de Paneles



**Material:** Black PVS

Reduce el ancho de la ranura para instalación de paneles

---

To reduce slot width for panel installation

### T Slot Reducing Profile-6

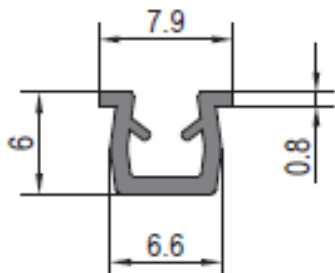

### T Slot Reducing Profile-8

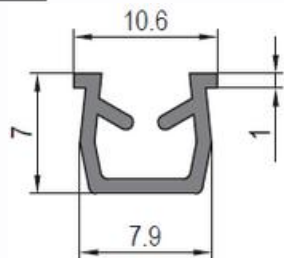
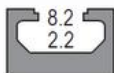

### T Slot Reducing Profile-10

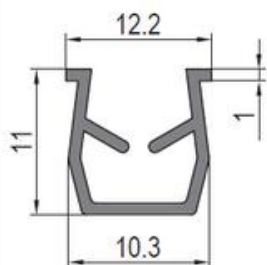
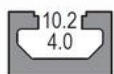

Description	Mass (g/m)	Delivery Length	Part No.
T Slot Reducing Profile-6	25		6.11.06
T Slot Reducing Profile-8	51	2000mm/bar	6.11.08
T Slot Reducing Profile-10	64		6.11.10

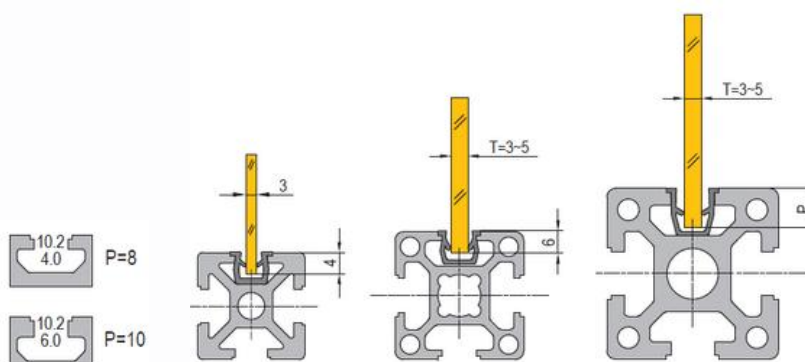

# Panel Mounting Block

Elementos de Instalación de Páneles



**Material:** Black PVS

Usado para unir el panel con varios tipos de grosor al perfil

The block is used to attach the panel with various thickness to the profile

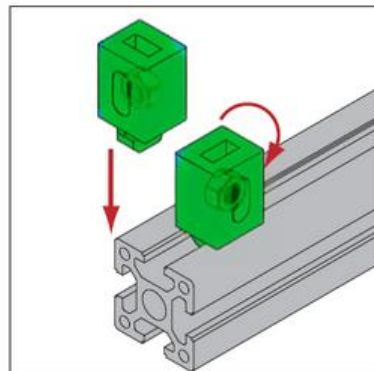

**Panel Mounting Block-6**



M5

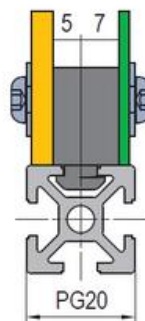
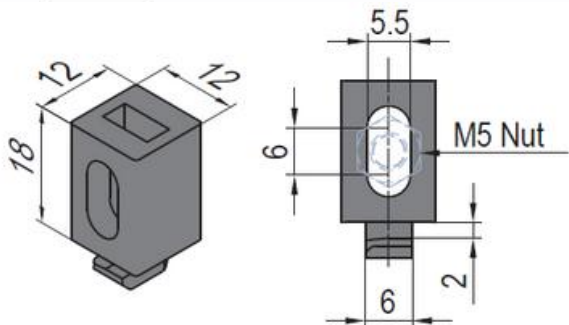

**Panel Mounting Block-8**



M6

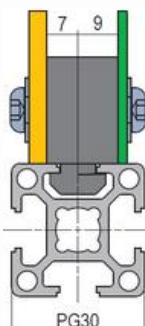
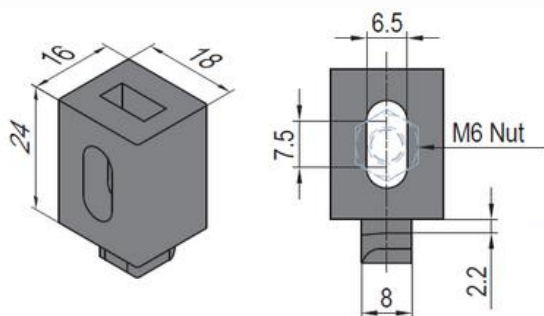
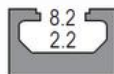

**Panel Mounting Block-10-4**



M6

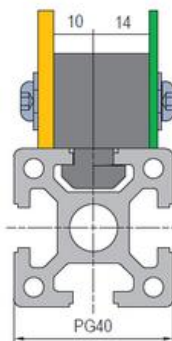
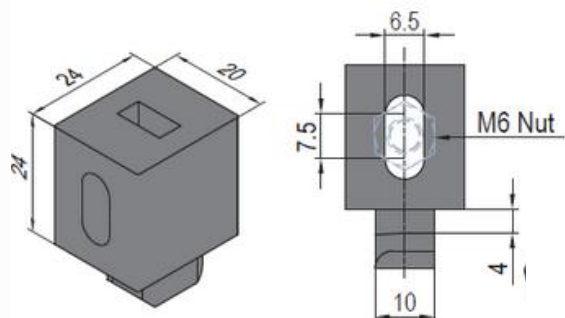

## Panel Mounting Block-10-6

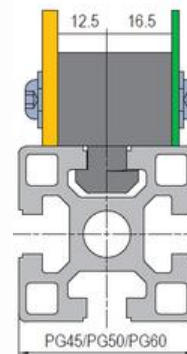
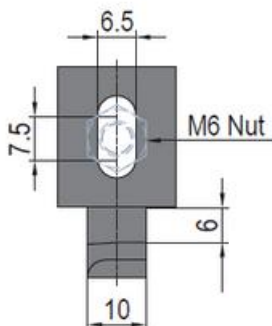
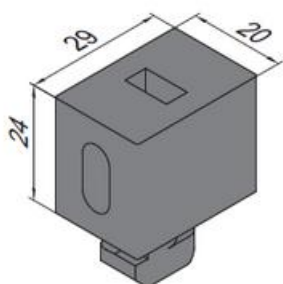
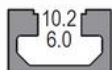

Description	PG	Fastening Set	Mass (g)	Part No.
Panel Mounting Block-6 (pcs)	PG20		4.4	6.21.06
Panel Mounting Block-6 (set)	PG20	1x <b>FM</b>	7	6.21.06.SET
Panel Mounting Block-8 (pcs)	PG30		9	6.21.08
Panel Mounting Block-8 (set)	PG30	1x <b>FN</b>	13.5	6.21.08.SET
Panel Mounting Block-10-4 (pcs)	PG40		15.8	6.21.10.04
Panel Mounting Block-10-4 (set)	PG40	1x <b>FP</b>	23.8	6.21.10.04.SET
Panel Mounting Block-10-6 (pcs)	PG45/50/60		20	6.21.10.06
Panel Mounting Block-10-6 (set)	PG45/50/60	1x <b>FP</b>	29	6.21.10.06.SET



# Panel Mounting Strip

Elementos de Instalación de Páneles



**Material:** Gray PVS

Usado para unir paneles de 3mm-5mm de grosor al perfil. Comúnmente utilizado en cuarto limpio

---

To attach the panel with 3mm and 5mm thickness to the profile, widely used in clean room.

### Panel Mounting Strip-8-5

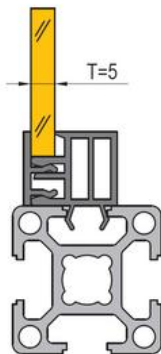
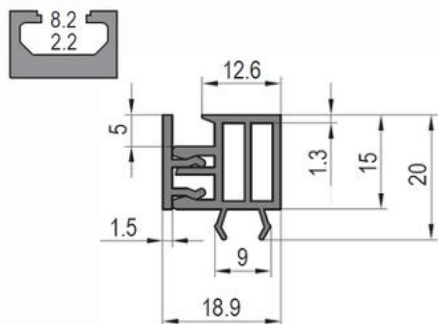

### Panel Mounting Strip-10-4-3

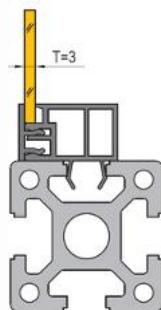
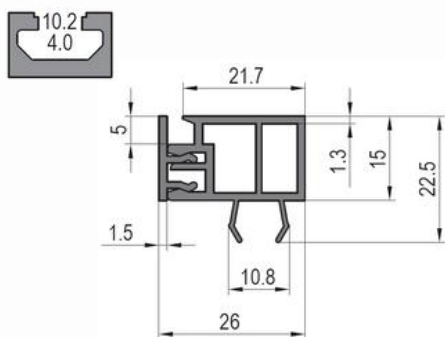

### Panel Mounting Strip-10-4-5

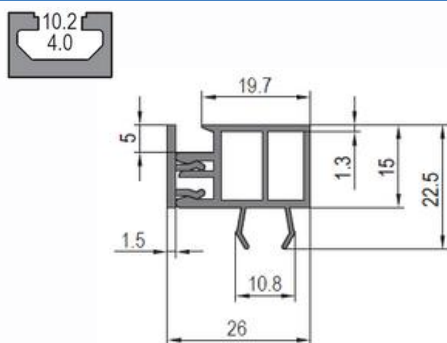

Description	PG	Mass	Delivery Length	Part No.
Panel Mounting Strip-8-5	PG30	220		6.31.08.02
Panel Mounting Strip-10-4-3	PG40	273	2000mm/bar	6.31.10.04.01
Panel Mounting Strip-10-4-5	PG40	260		6.31.10.04.02

# Mounting Block

Elementos de Instalación de Páneles



**Material:** Diecast Zinc

Usado para unir el centro con  $\varnothing 4$  al perfil estándar, el cual tiene mejores propiedades físicas.

Mounting block is used for fixing the mesh of  $\varnothing 4$  to the standard profiles, which has a better physical property

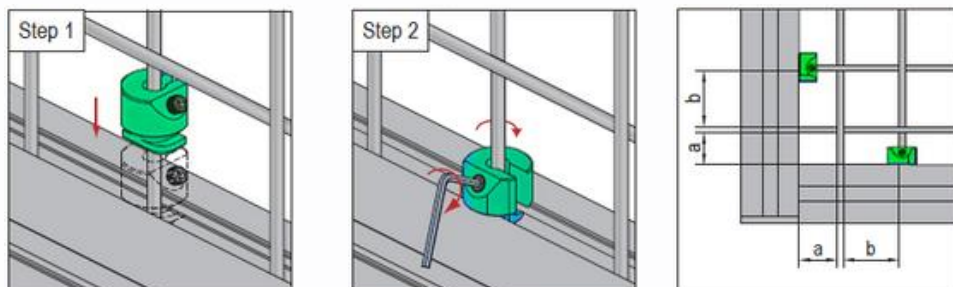

## Mounting Block-8

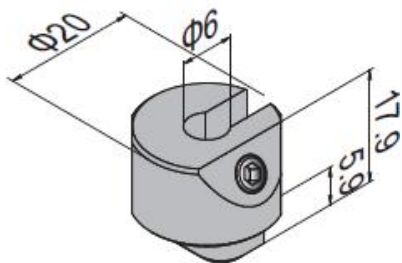
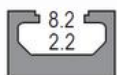

## Mounting Block-10-4

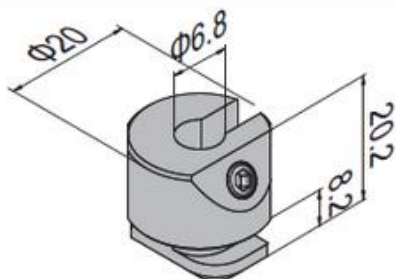
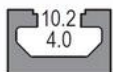

## Mounting Block-10-6

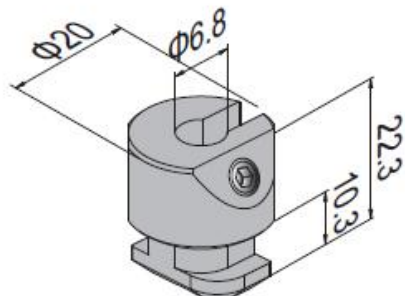

Description	PG	Mass (g/pcs)	Part No.
Mounting Block-8 (with top thread)	PG30	19	6.41.08.01
Mounting Block-10-4 (with top thread)	PG40	21	6.41.10.04.01
Mounting Block-10-6 (with top thread)	PG45/ 50/60	23	6.41.10.06.01

Note: The distance (a) between the nearest meshes and profiles have to be more than 20mm and less than  $b+5\text{mm}$  (b is the distance of the meshes). And the optimum distance between mounting blocks is 300mm to ensure the structure intensity.

# ELEMENTOS DE PUERTAS Y VENTANAS



Handle

Hinge

Lock

Magnet Catch

Door Lock

Sliding Door Profile

# Handle

Elementos de puertas y ventanas



**Material: PA6**

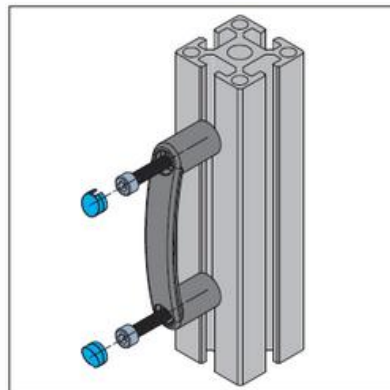

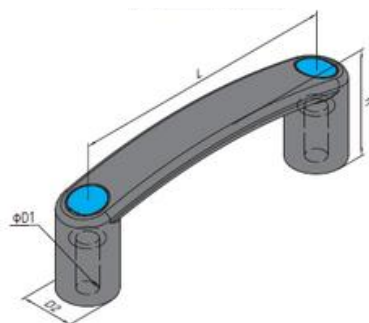

Description	PG	L (mm)	H (mm)	D1 (mm)	D2 (mm)	Fastening Set	Cap Color	Mass (g)	Part No.
PA6 Handle-90 (pcs)	PG15/20	90	36	6.5	18			23	7.11.90.06.BE
PA6 Handle-90 (set)	PG15/20	90	36	6.5	18	2x <b>CA</b>		41	7.11.90.06.BE.SET
PA6 Handle-90 (pcs)	PG15/20	90	36	6.5	18			23	7.11.90.06.BK
PA6 Handle-90 (set)	PG15/20	90	36	6.5	18	2x <b>CA</b>		41	7.11.90.06.BK.SET
PA6 Handle-90 (pcs)	PG30	90	36	6.5	18			23	7.11.90.08.BE
PA6 Handle-90 (set)	PG30	90	36	6.5	18	2x <b>CB</b>		45	7.11.90.08.BE.SET
PA6 Handle-90 (pcs)	PG30	90	36	6.5	18			23	7.11.90.08.BK
<b>PA6 Handle-90 (set)</b>	PG30	90	36	6.5	18	2x <b>CB</b>		45	<b>7.11.90.08.BK.SET</b> 
PA6 Handle-120 (pcs)	PG30	120	40	8.5	25			45	7.11.120.08.BE
PA6 Handle-120 (set)	PG30	120	40	8.5	25	2x <b>CB</b>		68	7.11.120.08.BE.SET
PA6 Handle-120 (pcs)	PG30	120	40	8.5	25			45	7.11.120.08.BK
PA6 Handle-120 (set)	PG30	120	40	8.5	25	2x <b>CB</b>		68	7.11.120.08.BK.SET
PA6 Handle-120 (pcs)	PG40	120	40	8.5	25			45	7.11.120.10.04.BE
PA6 Handle-120 (set)	PG40	120	40	8.5	25	2x <b>CD</b>		88	7.11.120.10.04.BE.SET
PA6 Handle-120 (pcs)	PG40	120	40	8.5	25			45	7.11.120.10.04.BK
<b>PA6 Handle-120 (set)</b>	PG45/50/60	120	40	8.5	25	2x <b>CD</b>		88	<b>7.11.120.10.04.BK.SET</b> 
PA6 Handle-120 (pcs)	PG45/50/60	120	40	8.5	25			45	7.11.120.10.06.BE
PA6 Handle-120 (set)	PG45/50/60	120	40	8.5	25	2x <b>CE</b>		104	7.11.120.10.06.BE.SET
PA6 Handle-120 (pcs)	PG45/50/60	120	40	8.5	25			45	7.11.120.10.06.BK
PA6 Handle-120 (set)	PG45/50/60	120	40	8.5	25	2x <b>CE</b>		104	7.11.120.10.06.BK.SET



# Guard Wing Handle





Elementos de puertas y ventanas

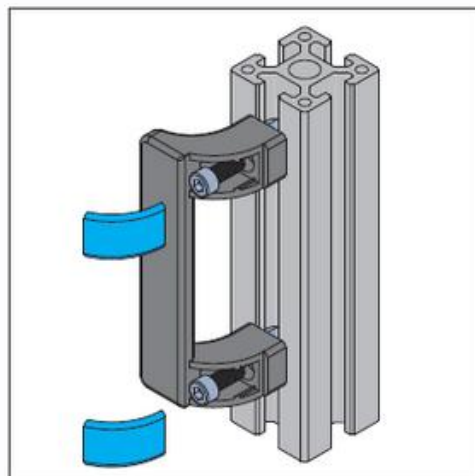

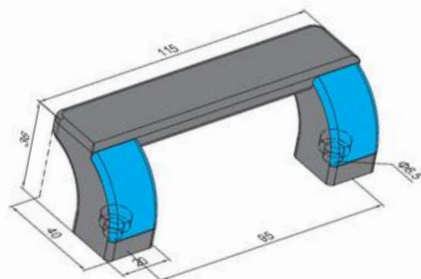
**Material:** PA6





Description	PG	Fastening Set	Cap Color	Mass (g)	Part No.
Guard Wing Handle-95 (pc)	PG30			70	7.12.95.08.BE
Guard Wing Handle-95 (set)	PG30	2x <b>CP</b>		88	7.12.95.08.BE.SET
Guard Wing Handle-95 (pc)	PG30			70	7.12.95.08.BK
Guard Wing Handle-95 (set)	PG30	2x <b>CP</b>		88	7.12.95.08.BK.SET
Guard Wing Handle-95 (pc)	PG40/45/50/60			70	7.12.95.10.BE
Guard Wing Handle-95 (set)	PG40/45/50/60	2x <b>CQ</b>		96	7.12.95.10.BE.SET
Guard Wing Handle-95 (pc)	PG40/45/50/60			70	7.12.95.10.BK
Guard Wing Handle-95 (set)	PG40/45/50/60	2x <b>CQ</b>		96	7.12.95.10.BK.SET

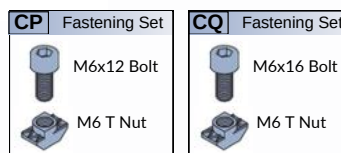

# Aluminium Handle

Elementos de puertas y ventanas



**Material:** Handle- Aluminium  
Cap- ABS

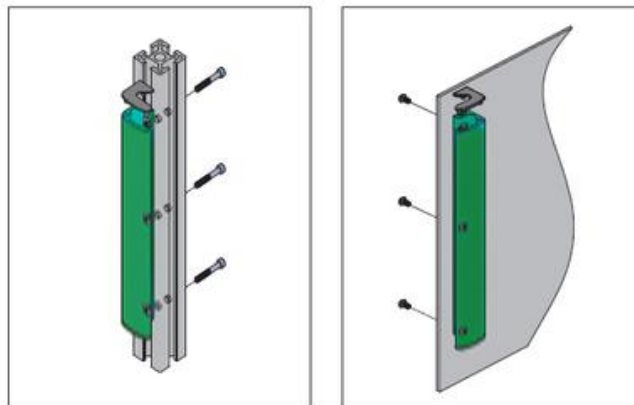

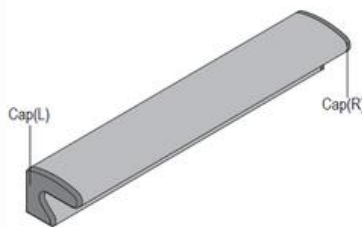
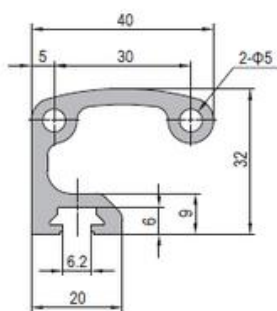
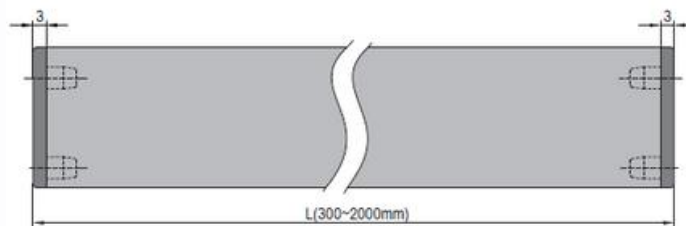

Application	Description	Cap Color	L (mm)	Fastening Set	Mass (g)	Part No.	
4mm Panel	Aluminum Handle (pc)		300		216	7.13.P.GY	
	Aluminum Handle (set)			3xPA	224	7.13.P.GY.SET	
	Aluminum Handle (pc)				216	7.13.P.BK	
	Aluminum Handle (set)			3xPA	224	7.13.P.BK.SET	
PG40/45 	Aluminum Handle (pc)					216	7.13.10.GY
	Aluminum Handle (set)			3xPB	231	7.13.10.GY.SET	
	Aluminum Handle (pc)					216	7.13.10.BK
	Aluminum Handle (set)			3xPB	231	7.13.10.BK.SET	

Single supply including 3 of M5 T Nuts (Reference No. 2.21.06.M5)

PA	Fastening Set	PB	Fastening Set
	M5x10 Bolt		M5x35 Bolt
	M5 Washer		M5 T Nut
	M5 T Nut		

# Hinge

Elementos de puertas y ventanas





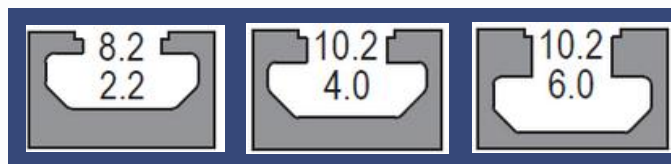

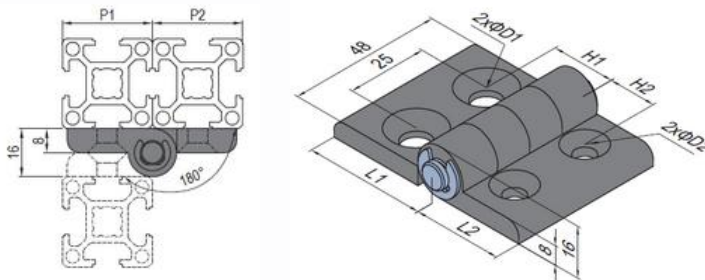
**Material: PA6**



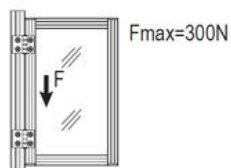

Description	H1 (mm)	H2 (mm)	L1 (mm)	L2 (mm)	D1 (mm)	D2 (mm)	Fastening Set	Mass (g)	Part No.
30/30 (pcs)	15	15	28	28	6.5	6.5		39	7.21.30.30
<b>30/30 (set)</b>	15	15	28	28	6.5	6.5	4xFL	73	<b>7.21.30.30.SET</b>
30/40 (pcs)	20	15	38	28	8.5	6.5		42	7.21.30.40
30/40 (set)	20	15	38	28	8.5	6.5	2xFG+2xFL	88	7.21.30.40.SET
30/45 (pcs)	22.5	15	43	28	8.5	6.5		44	7.21.30.45
30/45 (set)	22.5	15	43	28	8.5	6.5	2xFG+2xFL	81	7.21.30.45.SET
40/40 (pcs)	20	20	38	38	8.5	8.5		45	7.21.40.40
<b>40/40 (set)</b>	20	20	38	38	8.5	8.5	4xFG	108	<b>7.21.40.40.SET</b>
40/45 (pcs)	22.5	20	43	38	8.5	8.5		47	7.21.40.45
40/45 (set)	22.5	20	43	38	8.5	8.5	4xFG	110	7.21.40.45.SET
45/45 (pcs)	22.5	22.5	43	43	8.5	8.5		49	7.21.45.45
45/45 (set)	22.5	22.5	43	43	8.5	8.5	4xFG	112	7.21.45.45.SET



FG	Fastening Set	FL	Fastening Set
	M8x16 Bolt		M6x14 Bolt
	M8 T Nut		M6 T Nut

# Hinge

Elementos de puertas y ventanas



**Material:** Aluminium Countersink Hole

## Light Hinge

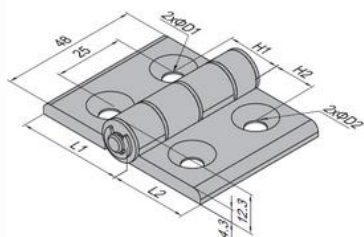
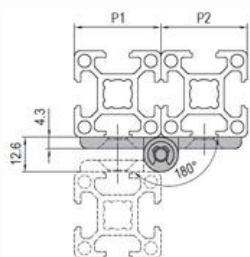

Description	H1 (mm)	H2 (mm)	L1 (mm)	L2 (mm)	D1 (mm)	D2 (mm)	Fastening Set	Mass (g)	Part No.
30/30 (pcs)	15	15	28	28	6.5	6.5		41	7.22.30.30.E
30/30 (set)	15	15	28	28	6.5	6.5	4xDJ	65	7.22.30.30.E.SET
30/40 (pcs)	20	15	38	28	6.5	6.5		46	7.22.30.40.E
30/40 (set)	20	15	38	28	6.5	6.5	2xDJ+2xFL	80	7.22.30.40.E.SET
30/45 (pcs)	22.5	15	38	28	6.5	6.5		46	7.22.30.45.E
30/45 (set)	22.5	15	38	28	6.5	6.5	2xDJ+2xDL	80	7.22.30.45.E.SET
40/40 (pcs)	20	20	38	38	6.5	6.5		51	7.22.40.40.E
40/40 (set)	20	20	38	38	6.5	6.5	4xFL	94	7.22.40.40.E.SET
40/45 (pcs)	22.5	20	38	38	6.5	6.5		51	7.22.40.45.E
40/45 (set)	22.5	20	38	38	6.5	6.5	2xFL+2xDL	95	7.22.40.45.E.SET
45/45 (pcs)	22.5	22.5	38	38	6.5	6.5		51	7.22.45.45.E
45/45 (set)	22.5	22.5	38	38	6.5	6.5	4xDL	96	7.22.45.45.E.SET

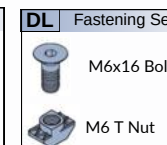
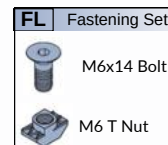
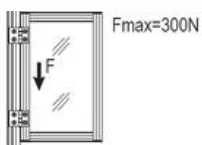

## Hinge- Aluminium Countersink Hole

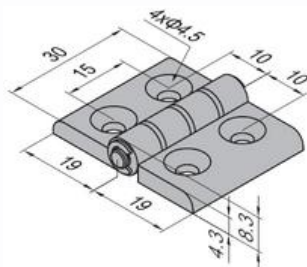
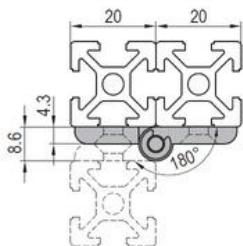
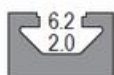

Description	Fastening Set	Mass (g)	Part No.
20/20 (pcs)		15	7.22.20.20
20/20 (set)	4xFE	25	7.22.20.20.SET

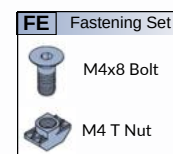
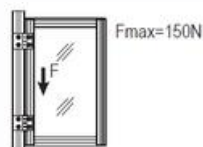

### Hinge- Aluminium Countersink Hole

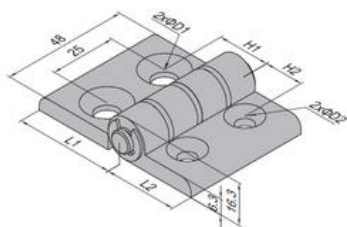
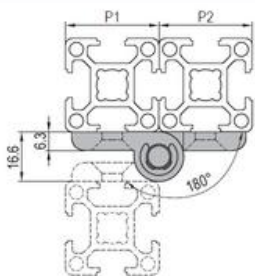

Description	H1 (mm)	H2 (mm)	L1 (mm)	L2 (mm)	D1 (mm)	D2 (mm)	Fastening Set	Mass (g)	Part No.
30/30 (pcs)	15	15	28	28	6.5	6.5		69	7.22.30.30
30/30 (set)	15	15	28	28	6.5	6.5	4x <b>FF</b>	97	7.22.30.30.SET
30/40 (pcs)	20	15	38	28	8.5	6.5		74	7.22.30.40
30/40 (set)	20	15	38	28	8.5	6.5	2x <b>FF</b> +2x <b>FG</b>	122	7.22.30.40.SET
30/45 (pcs)	22.5	15	38	28	8.5	6.5		74	7.22.30.45
30/45 (set)	22.5	15	38	28	8.5	6.5	2x <b>FF</b> +2x <b>FG</b>	122	7.22.30.45.SET
40/40 (pcs)	20	20	38	38	8.5	8.5		81	7.22.40.40
40/40 (set)	20	20	38	38	8.5	8.5	4x <b>FG</b>	149	7.22.40.40.SET
40/45 (pcs)	22.5	20	38	38	8.5	8.5		81	7.22.40.45
40/45 (set)	22.5	20	38	38	8.5	8.5	4x <b>FG</b>	149	7.22.40.45.SET
40/50 (pcs)	25	20	43	38	8.5	8.5		84	7.22.40.50
40/50 (set)	25	20	43	38	8.5	8.5	4x <b>FG</b>	152	7.22.40.50.SET
45/45 (pcs)	22.5	22.5	38	38	8.5	8.5		81	7.22.45.45
45/45 (set)	22.5	22.5	38	38	8.5	8.5	4x <b>FG</b>	149	7.22.45.45.SET
45/50 (pcs)	25	22.5	43	38	8.5	8.5		84	7.22.45.50
45/50 (set)	25	22.5	43	38	8.5	8.5	4x <b>FG</b>	152	7.22.45.50.SET
50/50 (pcs)	25	25	43	43	8.5	8.5		84	7.22.50.50
50/50 (set)	25	25	43	43	8.5	8.5	4x <b>FG</b>	155	7.22.50.50.SET

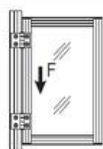

Fmax=400N

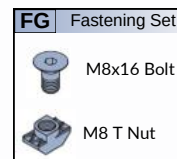

### Hinge- Aluminium Through Hole

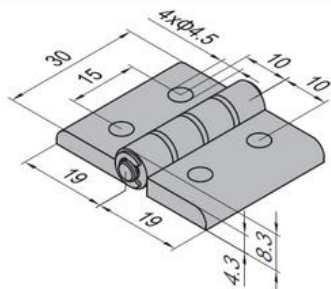
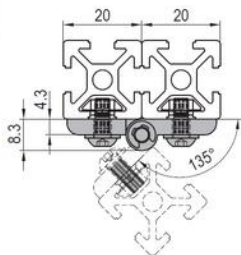

Description	Fastening Set	Mass (g)	Part No.
20/20 (pcs)		15	7.23.20.20
20/20 (set)	4x <b>PC</b>	29	7.23.20.20.SET

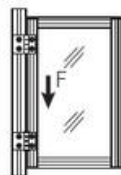

Fmax=150N

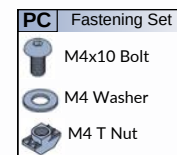

# Hinge- Aluminium Through Hole

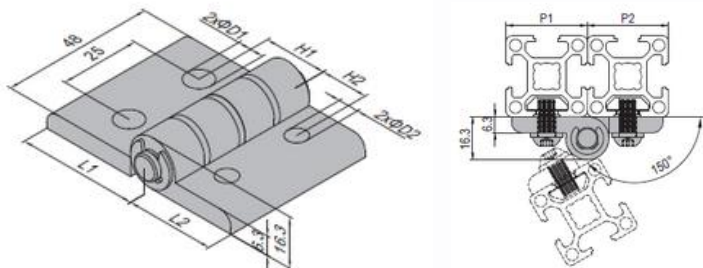

Description	H1 (mm)	H2 (mm)	L1 (mm)	L2 (mm)	D1 (mm)	D2 (mm)	Fastening Set	Mass (g)	Part No.
30/30 (pcs)	15	15	28	28	6.5	6.5		71	7.23.30.30
30/30 (set)	15	15	28	28	6.5	6.5	4x <b>FH</b>	99	7.23.30.30.SET
30/40 (pcs)	20	15	38	28	8.5	6.5		76	7.23.30.40
30/40 (set)	20	15	38	28	8.5	6.5	2x <b>FH</b> +2x <b>FJ</b>	124	7.23.30.40.SET
30/45 (pcs)	22.5	15	38	28	8.5	6.5		76	7.23.30.45
30/45 (set)	22.5	15	38	28	8.5	6.5	2x <b>FH</b> +2x <b>FK</b>	127	7.23.30.45.SET
40/40 (pcs)	20	20	38	38	8.5	8.5		83	7.23.40.40
40/40 (set)	20	20	38	38	8.5	8.5	4x <b>FJ</b>	151	7.23.40.40.SET
40/45 (pcs)	22.5	20	38	38	8.5	8.5		83	7.23.40.45
40/45 (set)	22.5	20	38	38	8.5	8.5	2x <b>FJ</b> +2x <b>FK</b>	156	7.23.40.45.SET
40/50 (pcs)	25	20	43	38	8.5	8.5		87	7.23.40.50
40/50 (set)	25	20	43	38	8.5	8.5	2x <b>FJ</b> +2x <b>FK</b>	159	7.23.40.50.SET
45/45 (pcs)	22.5	22.5	38	38	8.5	8.5		83	7.23.45.45
45/45 (set)	22.5	22.5	38	38	8.5	8.5	4x <b>FK</b>	161	7.23.45.45.SET
45/50 (pcs)	25	22.5	43	38	8.5	8.5		87	7.23.45.50
45/50 (set)	25	22.5	43	38	8.5	8.5	4x <b>FK</b>	167	7.23.45.50.SET
50/50 (pcs)	25	25	43	43	8.5	8.5		87	7.23.50.50
50/50 (set)	25	25	43	43	8.5	8.5	4x <b>FK</b>	164	7.23.50.50.SET

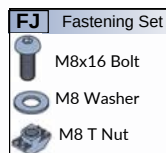
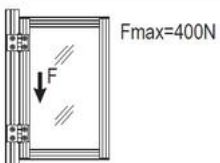

# Hinge

Elementos de puertas y ventanas



**Material:** Aluminium

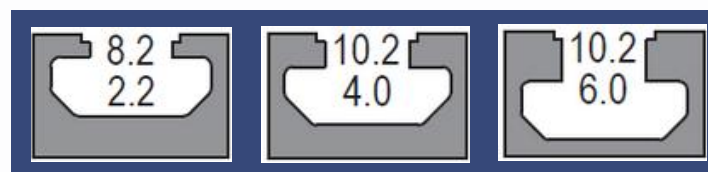
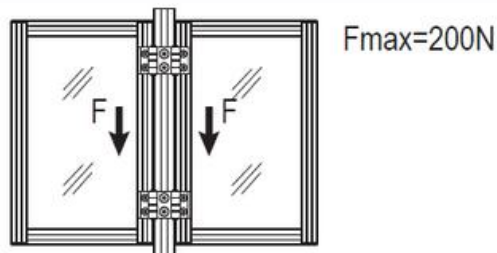

## Hinge- Aluminium Countersink Hole

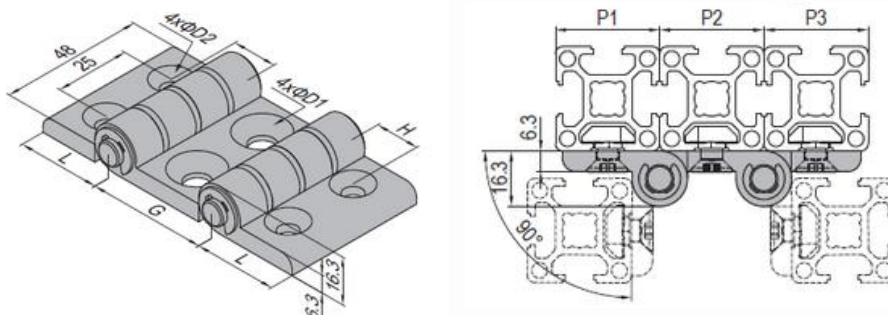



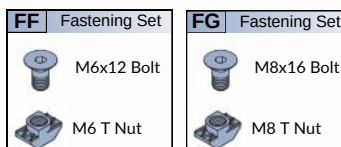

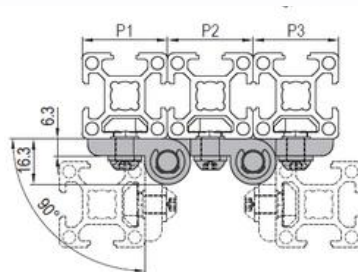
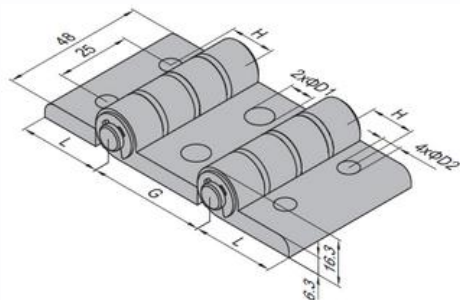

Description	G (mm)	H (mm)	L (mm)	D1 (mm)	D2 (mm)	Fastening Set	Mass (g)	Part No.
30/30/30 (pcs)	30	15	28	6.5	6.5		98	7.24.30.30.30
30/30/30 (set)	30	15	28	6.5	6.5	6x <b>FF</b>	140	7.24.30.30.30.SET
30/30/40 (pcs)	40	15	28	6.5	6.5		104	7.24.30.40.30
30/40/30 (set)	40	15	28	6.5	6.5	4x <b>FF</b> +2x <b>FG</b>	166	7.24.30.40.30.SET
30/45/30 (pcs)	45	15	28	6.5	6.5		108	7.24.30.45.30
30/45/30 (set)	45	15	28	6.5	6.5	4x <b>FF</b> +2x <b>FG</b>	170	7.24.30.45.30.SET
40/40/40 (pcs)	40	20	38	8.5	8.5		115	7.24.40.40.40
40/40/40 (set)	40	20	38	8.5	8.5	6x <b>FG</b>	217	7.24.40.40.40.SET
40/45/40 (pcs)	45	20	38	8.5	8.5		119	7.24.40.45.40
40/45/40 (set)	45	20	38	8.5	8.5	6x <b>FG</b>	221	7.24.40.45.40.SET
45/45/45 (pcs)	45	22.5	38	8.5	8.5		119	7.24.45.45.45
45/45/45 (set)	45	22.5	38	8.5	8.5	6x <b>FG</b>	221	7.24.45.45.45.SET



## Hinge- Aluminium Through Hole



Description	G (mm)	H (mm)	L (mm)	D1 (mm)	D2 (mm)	Fastening Set	Mass (g)	Part No.
30/30/30 (pcs)	30	15	28	6.5	6.5		100	7.25.30.30.30
30/30/30 (set)	30	15	28	6.5	6.5	6x <b>FH</b>	142	7.25.30.30.30.ST
30/40/30 (pcs)	40	15	28	8.5	6.5		107	7.25.30.40.30
30/40/30 (set)	40	15	28	8.5	6.5	4x <b>FH</b> +2x <b>FJ</b>	169	7.25.30.40.30.ST
30/45/30 (pcs)	45	15	28	8.5	6.5		111	7.25.30.45.30
30/45/30 (set)	45	15	28	8.5	6.5	4x <b>FH</b> +2x <b>FK</b>	175	7.25.30.45.30.ST
40/40/40 (pcs)	40	20	38	8.5	8.5		121	7.25.40.40.40
40/40/40 (set)	40	20	38	8.5	8.5	6x <b>FJ</b>	213	7.25.40.40.40.ST
40/45/40 (pcs)	45	20	38	8.5	8.5		125	7.25.40.45.40
40/45/40 (set)	45	20	38	8.5	8.5	4x <b>FJ</b> +2x <b>FK</b>	230	7.25.40.45.40.ST
45/45/45 (pcs)	45	22.5	38	8.5	8.5		125	7.25.45.45.45
45/45/45 (set)	45	22.5	38	8.5	8.5	6x <b>FK</b>	245	7.25.45.45.45.ST

<b>FH</b>	Fastening Set	<b>FJ</b>	Fastening Set	<b>FK</b>	Fastening Set
	M6x14 Bolt		M8x16 Bolt		M8x20 Bolt
	M6 Washer		M8 Washer		M8 Washer
	M6 T Nut		M8 T Nut		M8 T Nut

# Hinge

Elementos de puertas y ventanas



**Material:** Aluminium

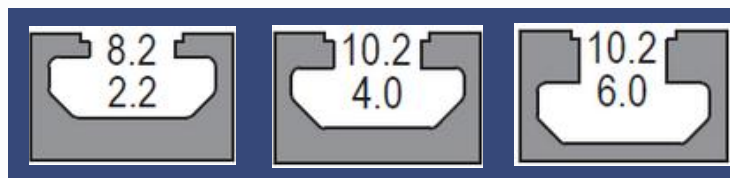
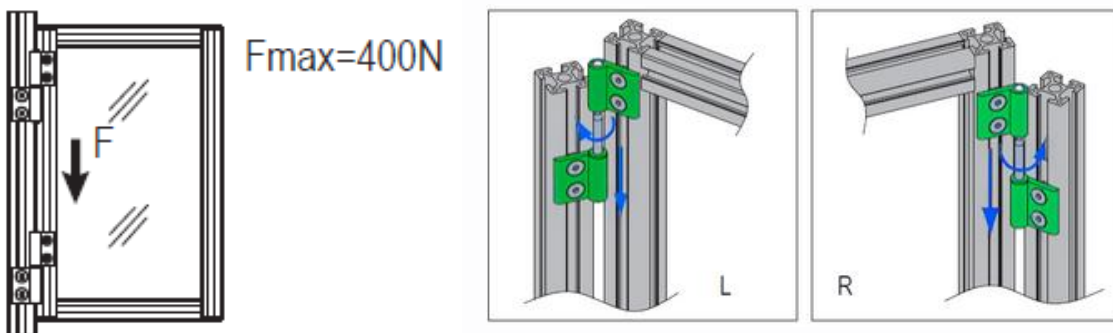

## Hinge- AI Removable Hinge L

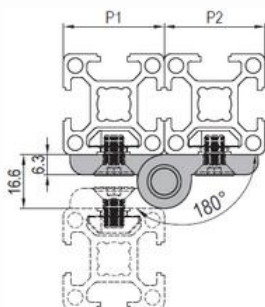
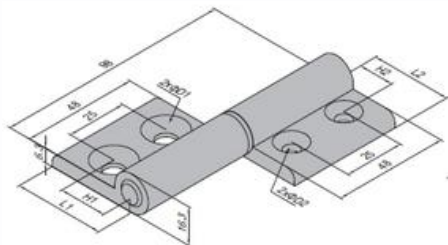

## Hinge- AI Removable Hinge R

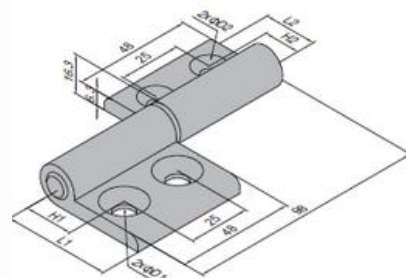

Description	H1 (mm)	H2 (mm)	L1 (mm)	L2 (mm)	D1 (mm)	D2 (mm)	Fastening Set	Mass (g)	Part No. (L)	Part No. (R)
30/30 (pcs)	15	15	28	28	6.5	6.5		105	7.26.30.30	7.27.30.30
30/30 (set)	15	15	28	28	6.5	6.5	4x <b>FF</b>	133	7.26.30.30.ST	7.27.30.30.ST
30/40 (pcs)	20	15	38	28	8.5	6.5		110	7.26.30.40	7.27.30.40
30/40 (set)	20	15	38	28	8.5	6.5	2x <b>FF</b> +2x <b>FG</b>	158	7.26.30.40.ST	7.27.30.40.ST
30/45 (pcs)	22.5	15	38	28	8.5	6.5		110	7.26.30.45	7.27.30.45
30/45 (set)	22.5	15	38	28	8.5	6.5	2x <b>FF</b> +2x <b>FG</b>	158	7.26.30.45.ST	7.27.30.45.ST
40/40 (pcs)	20	20	38	38	8.5	8.5		118	7.26.40.40	7.27.40.40
40/40 (set)	20	20	38	38	8.5	8.5	4x <b>FG</b>	186	7.26.40.40.ST	7.27.40.40.ST
40/45 (pcs)	22.5	20	38	38	8.5	8.5		118	7.26.40.45	7.27.40.45
40/45 (set)	22.5	20	38	38	8.5	8.5	4x <b>FG</b>	186	7.26.40.45.ST	7.27.40.45.ST
40/50 (pcs)	25	20	43	38	8.5	8.5		121	7.26.40.50	7.27.40.50
40/50 (set)	25	20	43	38	8.5	8.5	4x <b>FG</b>	189	7.26.40.50.ST	7.27.40.50.ST
45/45 (pcs)	22.5	22.5	38	38	8.5	8.5		118	7.26.45.45	7.27.45.45
45/45 (set)	22.5	22.5	38	38	8.5	8.5	4x <b>FG</b>	186	7.26.45.45.ST	7.27.45.45.ST
45/50 (pcs)	25	22.5	43	38	8.5	8.5		121	7.26.45.50	7.27.45.50
45/50 (set)	25	22.5	43	38	8.5	8.5	4x <b>FG</b>	189	7.26.45.50.ST	7.27.45.50.ST
50/50 (pcs)	25	25	43	43	8.5	8.5		121	7.26.50.50	7.27.50.50
50/50 (set)	25	25	43	43	8.5	8.5	4x <b>FG</b>	192	7.26.50.50.ST	7.27.50.50.ST

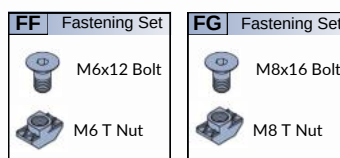

# Hinge

Elementos de puertas y ventanas



**Material:** Aluminium

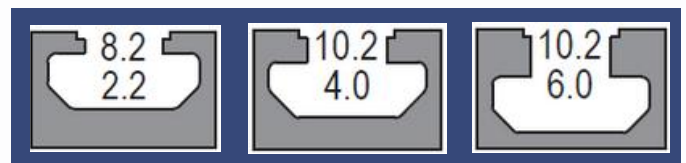
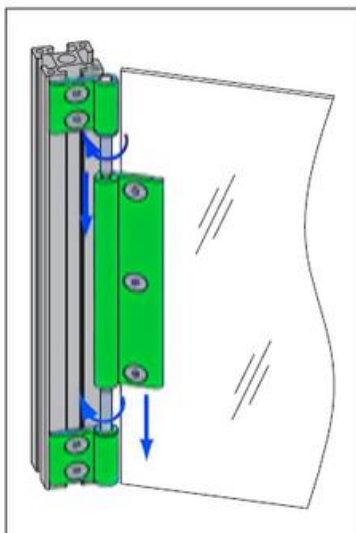
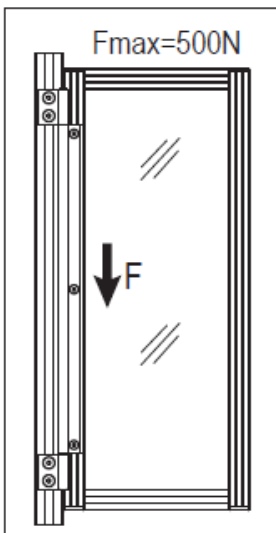



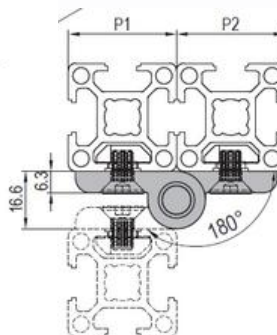
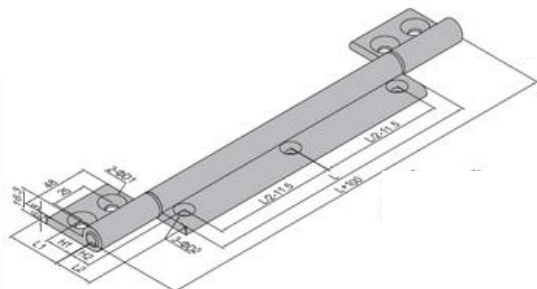

## Hinge- Long Aluminium Hinge



Description	H1 (mm)	H2 (mm)	L1 (mm)	L2 (mm)	D1 (mm)	D2 (mm)	L (mm)	Fastening Set	Mass (g)	Part No. (L)
30/30 (pcs)	15	15	28	28	6.5	6.5	500		515	7.28.30.30
30/30 (set)	15	15	28	28	6.5	6.5		7x <b>FF</b>	571	7.28.30.30.ST
30/40 (pcs)	20	15	38	28	8.5	6.5			525	7.28.30.40
30/40 (set)	20	15	38	28	8.5	6.5		3x <b>FF</b> +4x <b>FG</b>	617	7.28.30.40.ST
30/45 (pcs)	22.5	15	38	28	8.5	6.5			525	7.28.30.45
30/45 (set)	22.5	15	38	28	8.5	6.5		3x <b>FF</b> +4x <b>FG</b>	617	7.28.30.45.ST
40/40 (pcs)	20	20	38	38	8.5	8.5			605	7.28.40.40
40/40 (set)	20	20	38	38	8.5	8.5		7x <b>FG</b>	724	7.28.40.40.ST
40/45 (pcs)	22.5	20	38	38	8.5	8.5			605	7.28.40.45
40/45 (set)	22.5	20	38	38	8.5	8.5		7x <b>FG</b>	724	7.28.40.45.ST
40/50 (pcs)	22.5	22.5	38	38	8.5	8.5			605	7.28.40.50
40/50 (set)	22.5	22.5	38	38	8.5	8.5		7x <b>FG</b>	724	7.28.40.50.ST

Note: The length could be customized according to customer's requirements (100~1000)

<b>FF</b> Fastening Set	<b>FG</b> Fastening Set
 M6x12 Bolt	 M8x16 Bolt
 M6 T Nut	 M8 T Nut

# Lock

Elementos de puertas y ventanas

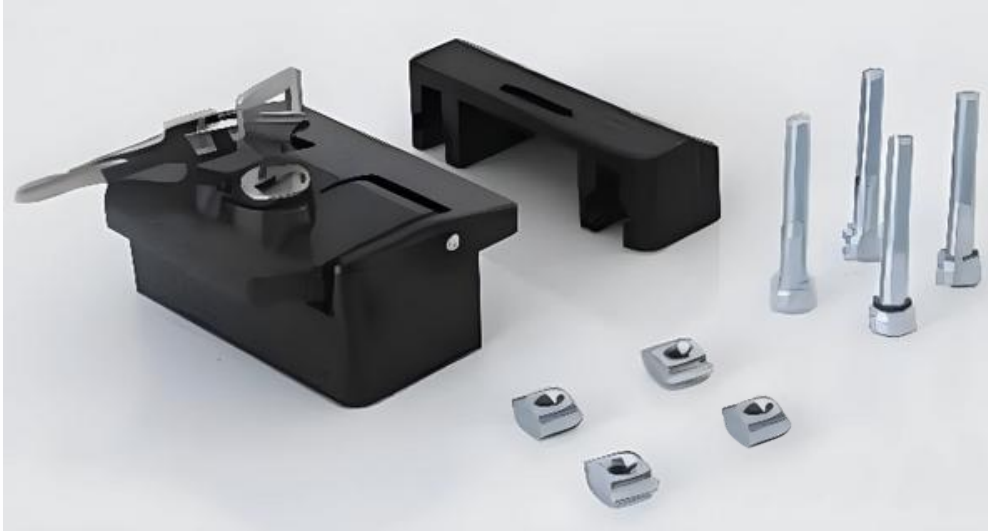

**Material:** Die cast Zinc, black electrophoresis

Seguro de metal compacto con un diseño de auto-seguro

Compact metal lock with self-locking design

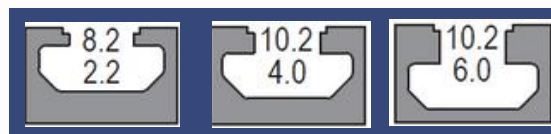
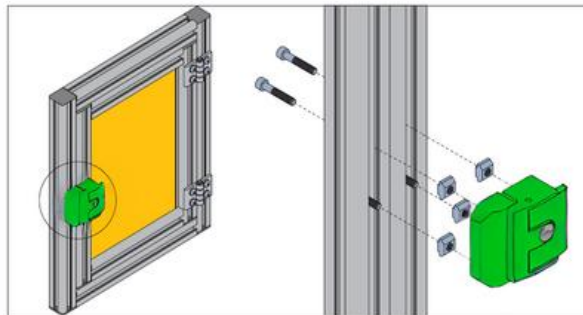

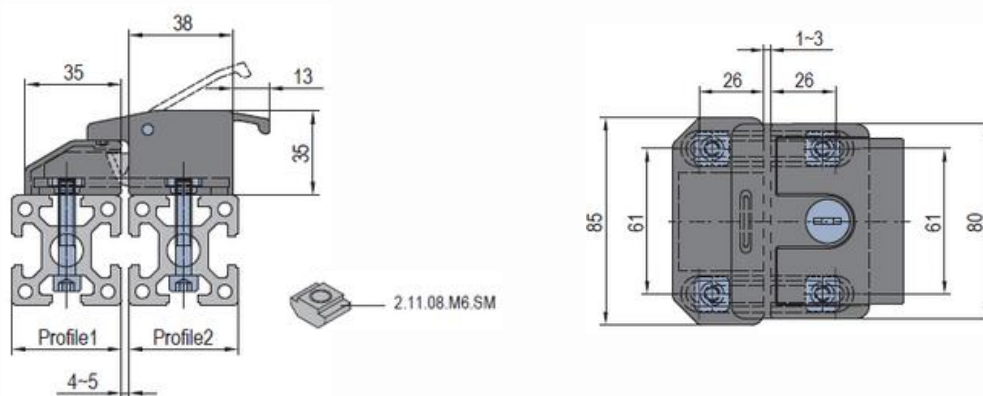

Description	Profile 1	Profile 2	Fastening Set	Mass (g)	Part No.
Lock (pcs)				690	7.31
Lock-3030 (set)	PG30 30	PG30 30	4x <b>EL</b>	719	7.31.30.30
Lock-4030 (set)	PG40 40	PG30 30	2x <b>EL</b> 2x <b>EM</b>	724	7.31.40.30
Lock-4040 (set)	PG40 40	PG40 40	4x <b>EM</b>	728	7.31.40.40
Lock-4530 (set)	PG45 45	PG30 30	2x <b>EL</b> 2x <b>EM</b>	726	7.31.45.30
Lock-4540 (set)	PG45 45	PG40 40	2x <b>EM</b> 2x <b>EN</b>	731	7.31.45.40
Lock-4545 (set)	PG45 45	PG45 45	4x <b>EM</b>	733	7.31.45.45



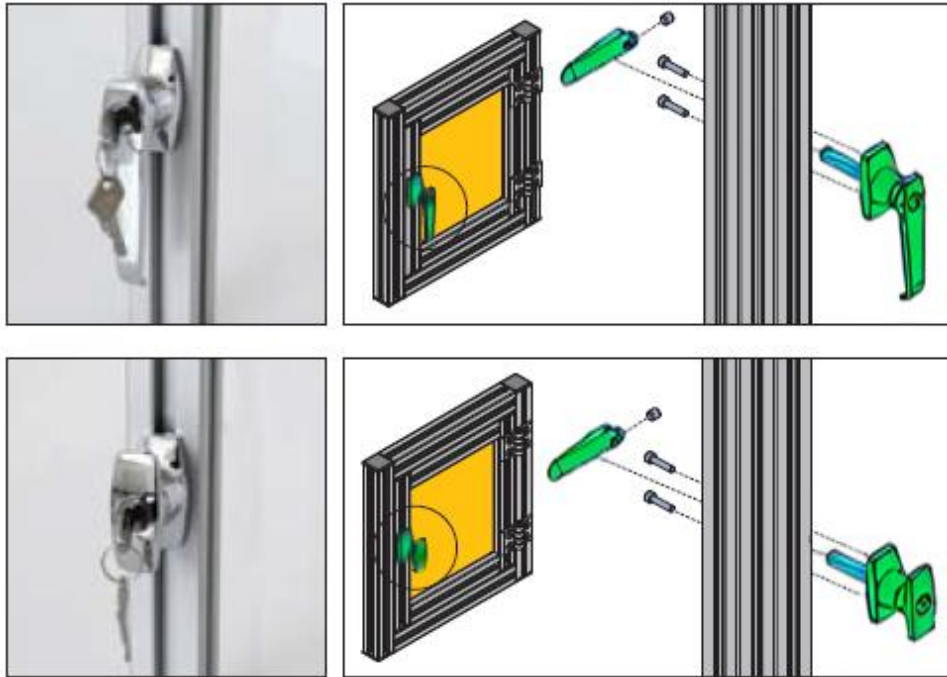

**Material:** Zinc Alloy, polish finish

Seguro de metal compacto con un diseño de auto-seguro

Compact metal lock with self-locking design

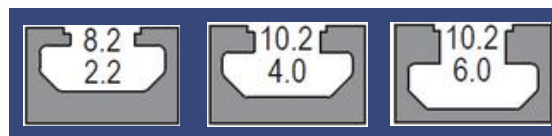

## L Lock

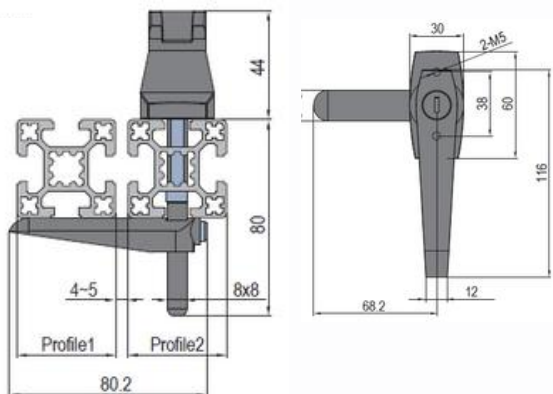

## T Lock

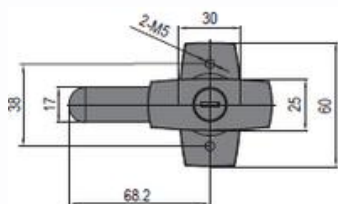
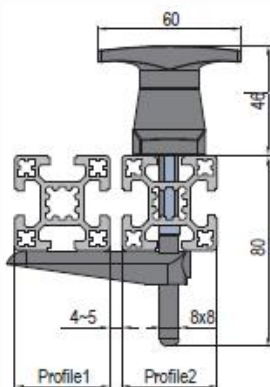

Description	Profile 1	Profile 2	Fastening Set	Mass (g)	Part No.
L Lock-3030	PG30	PG30	<b>DH+2xEG</b>	290	7.32.30.30
L Lock-4030	PG40	PG30	<b>DH+2xEG</b>	290	7.32.40.30
L Lock-4530	PG45	PG30	<b>DH+2xEG</b>	290	7.32.45.30
L Lock-4040	PG40	PG40	<b>DH+2xEH</b>	294	7.32.40.40
L Lock-4540	PG45	PG40	<b>DH+2xEH</b>	294	7.32.45.30
L Lock-5040	PG50	PG40	<b>DH+2xEH</b>	294	7.32.50.40
L Lock-4545	PG45	PG45	<b>DH+2xEK</b>	296	7.32.45.45
L Lock-5045	PG50	PG45	<b>DH+2xEK</b>	296	7.32.50.45
L Lock-5050	PG50	PG50	<b>DH+2xEK</b>	296	7.32.50.50
T Lock-3030	PG30	PG30	<b>DH+2xEG</b>	270	7.33.30.30
T Lock-4030	PG40	PG30	<b>DH+2xEG</b>	270	7.33.40.30
T Lock-4530	PG45	PG30	<b>DH+2xEG</b>	270	7.33.45.30
T Lock-4040	PG40	PG40	<b>DH+2xEH</b>	274	7.33.40.40
T Lock-4540	PG45	PG40	<b>DH+2xEH</b>	274	7.33.45.40
T Lock-5040	PG50	PG40	<b>DH+2xEH</b>	274	7.33.50.40
T Lock-4545	PG45	PG45	<b>DH+2xEK</b>	276	7.33.45.45
T Lock-5045	PG50	PG45	<b>DH+2xEK</b>	276	7.33.50.45
T Lock-5050	PG50	PG50	<b>DH+2xEK</b>	276	7.33.50.50

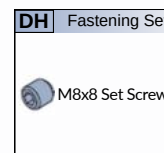
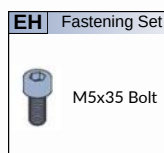
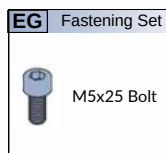



**Material:** Magnet Catch-Aluminium alloy  
Connectors- Zinc plated steel

Cuando el magnet catch es instalado en el marco inferior para puertas, la puerta debe ser mayor a 400mm

---

When the magnet catch is installed on the lower door frame, the door should be more than 400mm

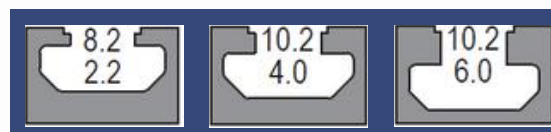

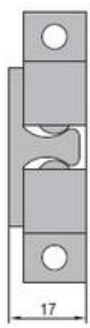
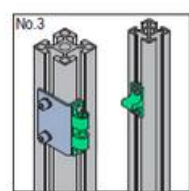
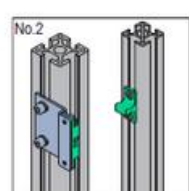
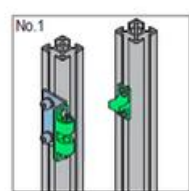
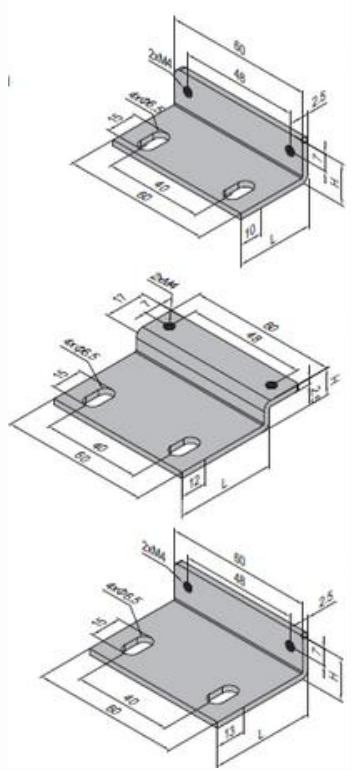
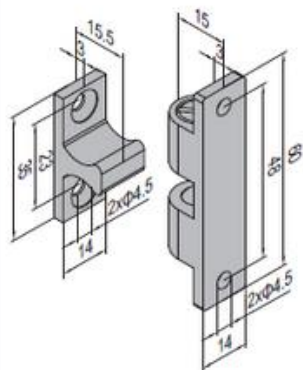



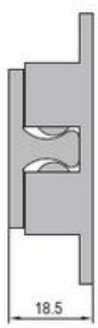



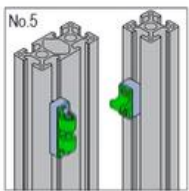
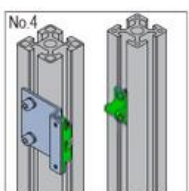
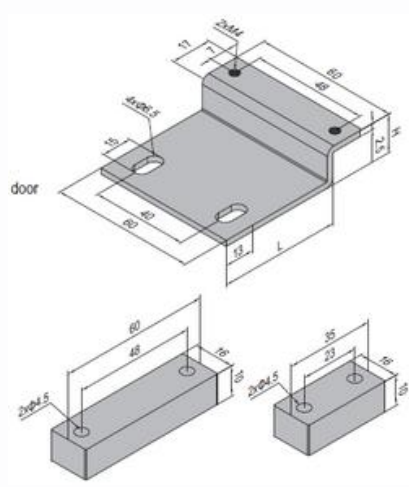









Tighten Status 1



















Tighten Status 2



Description	L (mm)	H (mm)	Fastening Set	Mass (g)	Part No.
Magnet Catch-14 (pcs)				26	7.41.14
<b>Magnet Catch-14 (Profile 3030 for Door, Profile 3030 for Doorframe set No.1)</b>	31	17	2x <b>CF</b> +2x <b>PF</b> +2x <b>CJ</b>	130	<b>7.41.14.3030.ST</b> 
Magnet Catch-14 (Profile 3030 for Door, Profile 4545 for Doorframe set No.2)	41	11	2x <b>CF</b> +2x <b>PF</b> +2x <b>CK</b>	139	7.41.14.3040.ST
Magnet Catch-14 (Profile 3030 for Door, Profile 4545 for Doorframe set No.3)	42	14	2x <b>CF</b> +2x <b>PF</b> +2x <b>CN</b>	145	7.41.14.3045.ST

CF Fastening Set	PF Fastening Set	CJ Fastening Set	CK Fastening Set	CN Fastening Set
 M4x10 Bolt	 M4x8 Bolt	 M6x10 Bolt	 M6x14 Bolt	 M6x16 Bolt
 M4 T Nut	 M4 Spring Bolt	 M6 Spring Washer	 M6 Spring Washer	 M6 Spring Washer
	 M4 Washer	 M6 T Nut	 M6 T Nut	 M6 T Nut

Description	L (mm)	H (mm)	Fastening Set	Mass (g)	Part No.
<b>Magnet Catch-14 (Profile 4040 for Door, Profile 4040 for Doorframe set No.1)</b>	45	17	2x <b>CG</b> +2x <b>PF</b> +2x <b>CK</b>	147	<b>7.41.14.4040.ST</b> 
Magnet Catch-14 (Profile 4040 for Door, Profile 4545 for Doorframe set No.4)	51	16	2x <b>CG</b> +2x <b>PF</b> +2x <b>CN</b>	151	7.41.14.4045.ST
Magnet Catch-14 (Profile 4040 for Door, Profile 4080 for Doorframe set No.5)			2x <b>CL</b> +2x <b>CY</b>	255	7.41.14.4080.ST
Magnet Catch-14 (Profile 4040 for Door, Profile 5050 for Doorframe set No.4)	51	11	2x <b>CG</b> +2x <b>PF</b> +2x <b>CN</b>	145.5	7.41.14.4050.ST
Magnet Catch-14 (Profile 4545 for Door, Profile 4545 for Doorframe set No.1)	45	17	2x <b>CG</b> +2x <b>PF</b> +2x <b>CN</b>	151	7.41.14.4545.ST
Magnet Catch-14 (Profile 4545 for Door, Profile 5050 for Doorframe set No.4)	51	16	2x <b>CG</b> +2x <b>PF</b> +2x <b>CN</b>	151	7.41.14.4550.ST
Magnet Catch-14 (Profile 5050 for Door, Profile 5050 for Doorframe set No.1)	50	17	2x <b>CG</b> +2x <b>PF</b> +2x <b>CN</b>	149	7.41.14.5050.ST

CG Fastening Set	PF Fastening Set	CK Fastening Set	CL Fastening Set	CY Fastening Set	CN Fastening Set
 M4x14 Bolt	 M4x8 Bolt	 M6x14 Bolt	 M4x25 Bolt	 M4x20 Bolt	 M6x16 Bolt
 M4 T Nut	 M4 Spring Bolt	 M6 Spring Washer	 M4 Spring Washer	 M4 T Nut	 M6 Spring Washer
	 M4 Washer	 M6 T Nut	 M4 T Nut		 M6 T Nut

# Door Lock

Elementos de puertas y ventanas





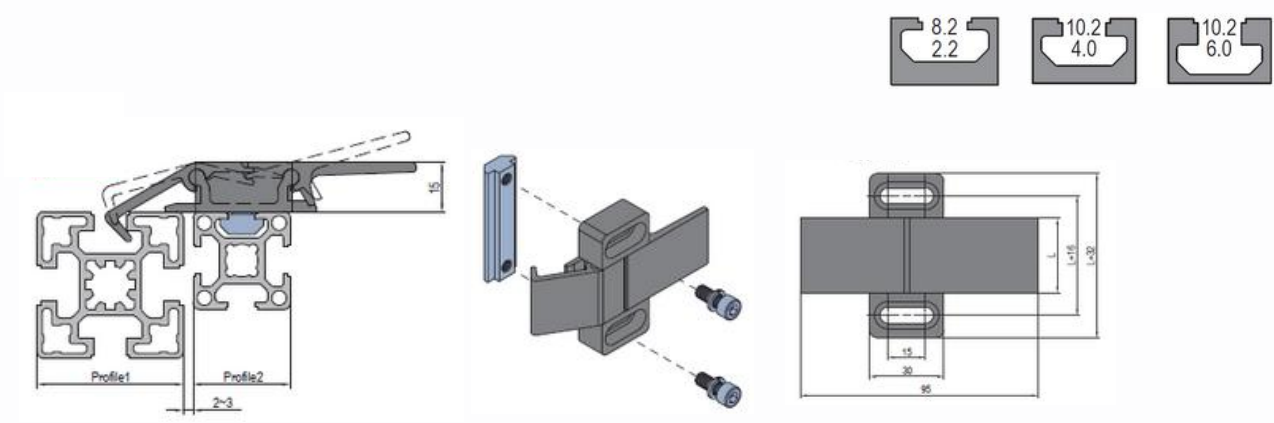

**Material:** Block- diecast aluminum, black electrophoresis  
Door Lock - Black electrophoresis



Description	Profile 1	Profile 2	L (mm)	Fastening Set	Mass (g)	Part No.
Door Locks-3040	PG40	PG30	30	2x <b>CU</b> +1+ <b>EP</b>	115	7.42.30.3040
Door Locks-3045	PG45	PG30	30	2x <b>CU</b> +1+ <b>EP</b>	115	7.42.30.3045
Door Locks-4040	PG40	PG40	30	2x <b>CU</b> +1+ <b>EP</b>	140	7.42.30.4040
Door Locks-4045	PG45	PG40	50	2x <b>CU</b> +1+ <b>EP</b>	185	7.42.30.4045
Door Locks-4545	PG45	PG45	50	2x <b>CV</b> +1+ <b>EP</b>	187	7.42.30.4545

Note: Including block and special nut

<b>CU</b> Fastening Set	<b>CV</b> Fastening Set	<b>EP</b> Fastening Set
 M6x16 Bolt  M6 Spring Washer	 M6x20 Bolt  M6 Spring Washer	 Special Nut

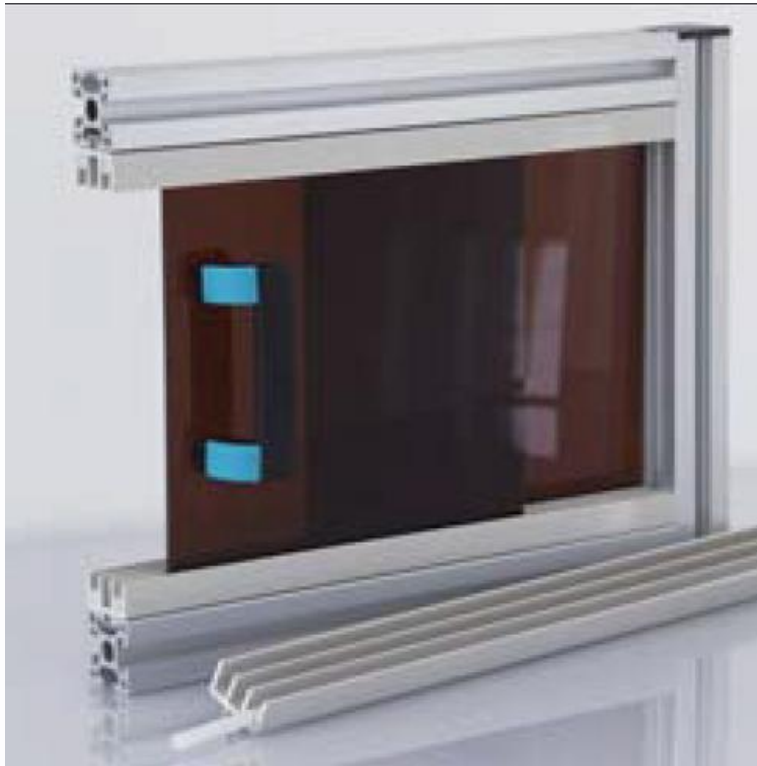

**Material:** PE Bar- HD-PE  
Sliding door profile- PVC

El perfil para puerta deslizadora se coloca en el perfil estructural y es recomendado para puertas deslizadoras de poco peso

---

The sliding door profile clips into strut profiles and is suitable for light-weight sliding doors.

## Sliding door Profile-8

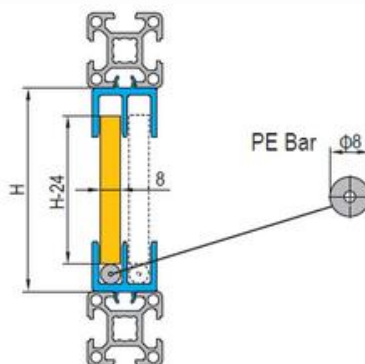
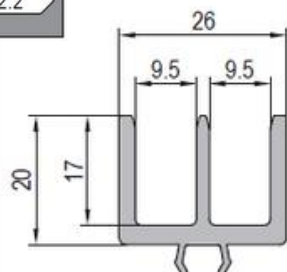
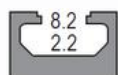

## Sliding door Profile-10-4

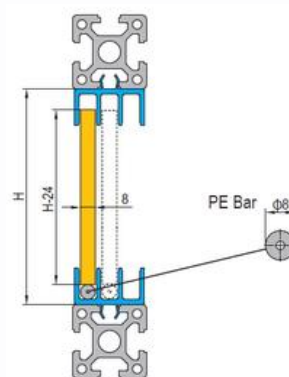
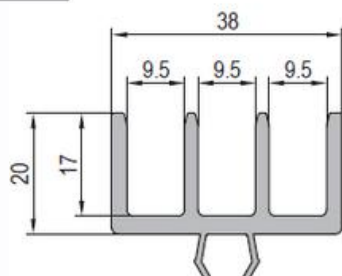
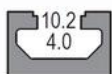

Description	PG	Mass (g/m)	Delivery Length	Part No.
Sliding Door Profile-8	PG30	330	3000mm/bar	7.51.08
Sliding Door Profile-8 (Including 2 pcs PE bar)	PG30	390		7.51.08.ST
Sliding Door Profile-10-4	PG40	450		7.51.10.04
Sliding Door Profile-10-4 (Including 2 pcs PE bar)	PG40	510		7.51.10.04.02.ST
Sliding Door Profile-10-4 (Including 3 pcs PE bar)	PG40	540		7.51.10.04.03.ST

# ACCESORIOS ADICIONALES



Suspended Glider  
Swivel Angle Plate  
Potential qualiser Nut  
Joint  
Frame Joint  
Mounting Adaptor for Roller  
Telescope unit.



**Material:** Glider-PA6+ GF30  
Hook- Zinc plated steel

El gancho deslizante puede suspenderse de la ranura del perfil

The glider can be suspended in profile slot.

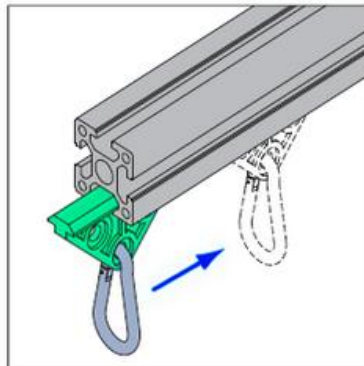

## Suspended Glider-8

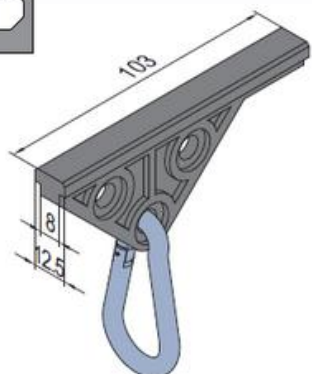
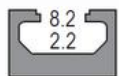

Description	Static Load (N)	Mass (g)	Part No.
Suspended Glider-8	200	48	8.11.08

## Suspended Glider-10

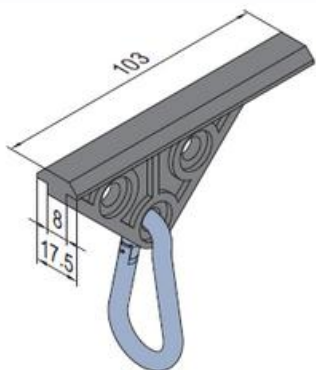
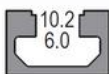
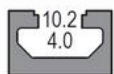

Description	Static Load (N)	Mass (g)	Part No.
Suspended Glider-10	200	48	8.11.10

# Swivel Angle Plate

Accesorios Adicionales



**Material:** Steel, black electrophoresis

Infinitas variables para ajustar la inclinación al ángulo deseado

Infinitely variable adjusting of inclination with swivel angle.

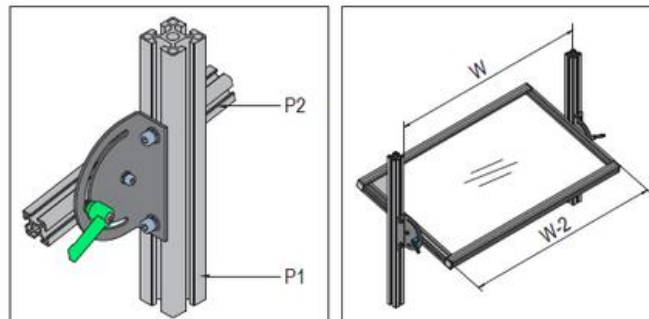



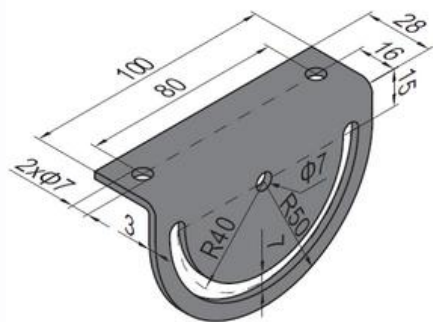
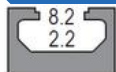



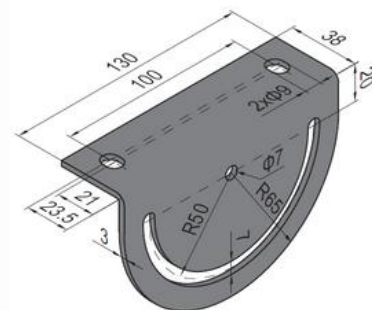









## Swivel Angle Plate-PG30



## Swivel Angle Plate-PG40/45



Description	P1	P2	Fastening Set	Mass (g)	Part No.
Swivel Angle Plate-PG30 (pcs)				160	8.21.30
Swivel Angle Plate-PG30 (set)	PG30	PG30	1xFR+1xFT+2xR	270	8.21.31.ST
Swivel Angle Plate-PG40/45 (pcs)				288	8.21.40
Swivel Angle Plate-PG40/45-PG30 (set)	PG40/45	PG30	1xFR+1xFT+2xFV	288	8.21.40.30.ST
<b>Swivel Angle Plate-PG40/45-PG40/45 (set)</b>	PG40/45	PG40/45	1xFR+1xFT+2xFW	443	<b>8.21.40.40.ST</b> 

FR	FT	FV	FW	R
Fastening Set	Fastening Set	Fastening Set	Fastening Set	Fastening Set
 M6x12 Adjustable Handle	 M6x12 Bolt	 M8x16 Bolt	 M6x16 Bolt	 M6x12 Bolt
 M6 Washer	 M6 Washer	 M8 Washer	 M6 Washer	 M6 Washer
 M6 Pre-set Nut	 M6 Pre-set Nut	 M8 T Nut	 M6 Pre-set Nut	 M6 T Nut

# Potential Equaliser Nut

Accesorios Adicionales

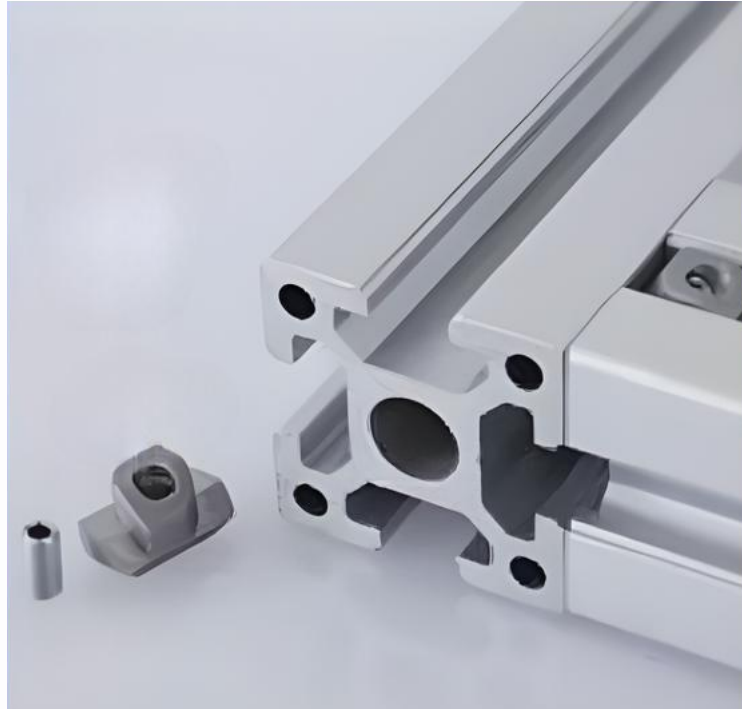

**Material:** Zinc alloy

La tuerca final en T se tuerce en el surco del perfil a un ángulo de 45 grados. Conduce la estática hacia dentro y anivelar el potencial.

Potential Equaliser Nut penetrates the oxide film of the profiles at 45° to conduct the static inside of the profiles and to average the potential.

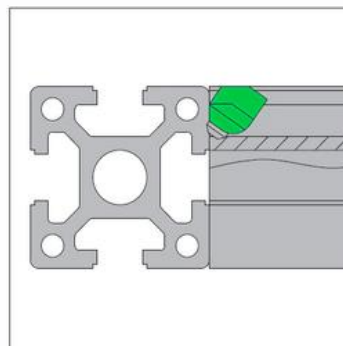

### Potential Equaliser Nut-8-M4

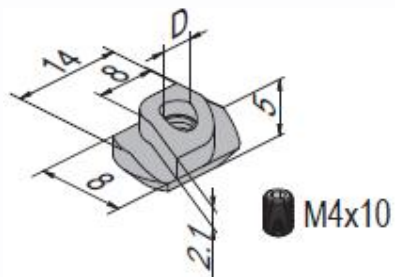
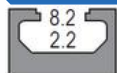

### Potential Equaliser Nut-10-M5

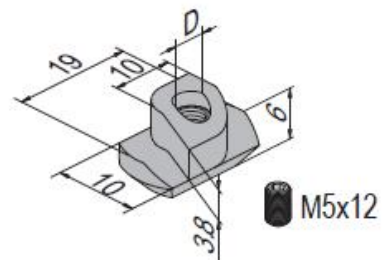

Description	D	Mass (g/pcs)	Part No.
Potential Equaliser Nut-8-M4 (with top thread)	M4	3	8.22.08.M4
Potential Equaliser Nut-10-M5 (with top thread)	M5	7	8.22.10.M5

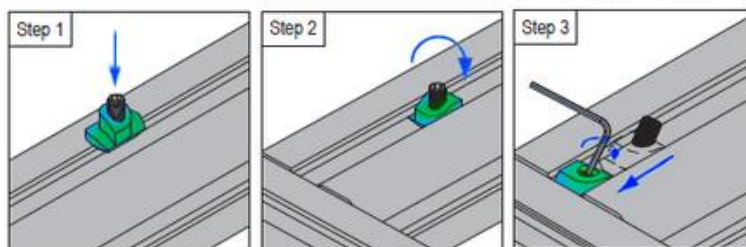

# Joint

Accesorios Adicionales

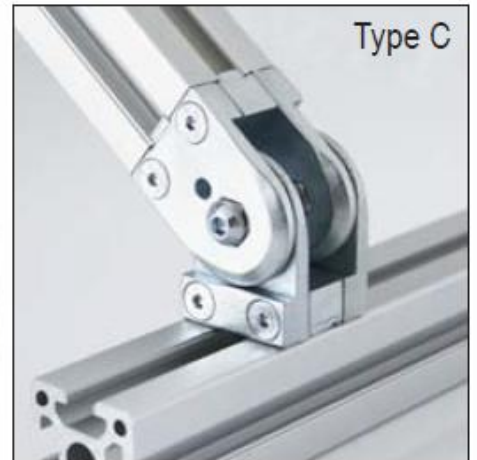
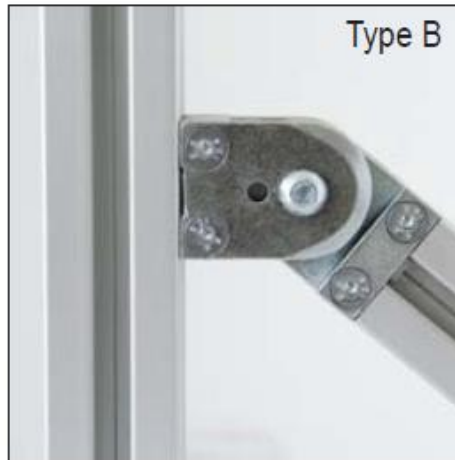
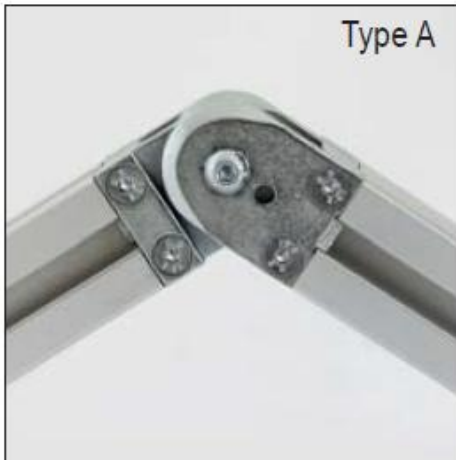

**Material:** Zinc plated steel

Usado para conectar perfiles movibles

---

To connect movable profiles

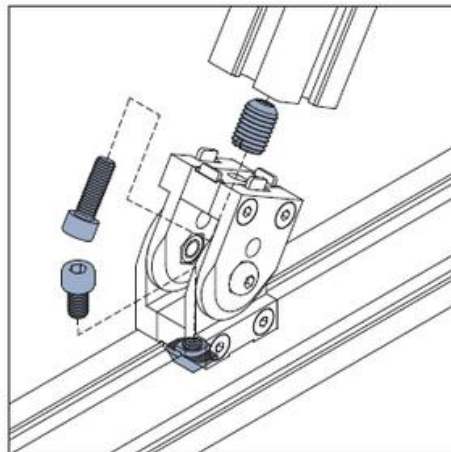

## Joint- Type A

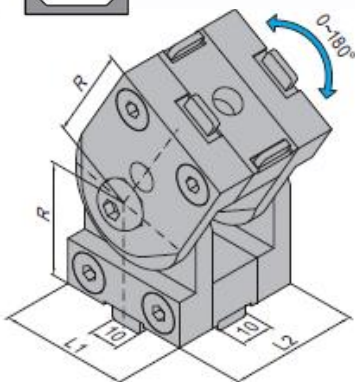

## Joint- Type B

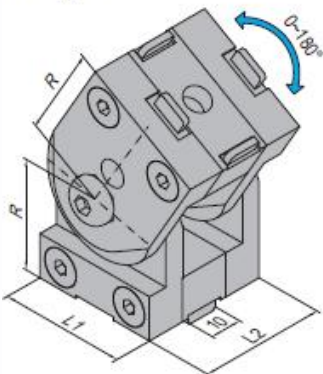

## Joint- Type C

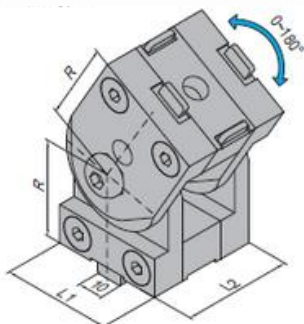

Description	L1 (mm)	L2 (mm)	R (mm)	Fastening Set	Mass (g)	Part No.
Joint-Type A- 4040	40	40	35	2x <b>FX</b>	560	8.31.4040A
Joint-Type A- 4060	40	60	37.5		680	8.31.4060A
Joint-Type A- 4545	45	45	35	2x <b>FX</b>	650	8.31.4545A
Joint-Type A- 4560	45	60	37.5		800	8.31.4560A
Joint-Type B- 4040	40	40	35	1x <b>FD</b> +1x <b>FX</b>	575	8.31.4040B
Joint-Type B- 4060	40	60	35		695	8.31.4060B
Joint-Type B- 4545	45	45	37.5	1x <b>FD</b> +1x <b>FX</b>	665	8.31.4545B
Joint-Type B- 4560	45	60	37.5		815	8.31.4560B
Joint-Type C- 4040	40	40	35	1x <b>FD</b> +1x <b>FX</b>	575	8.31.4040C
Joint-Type C- 4060	40	60	35		695	8.31.4060C
Joint-Type C- 4545	45	45	37.5	1x <b>FD</b> +1x <b>FX</b>	665	8.31.4545C
Joint-Type C- 4560	45	60	37.5		815	8.31.4560C

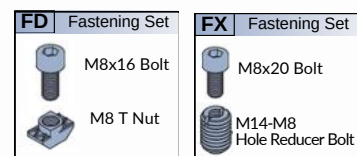

## Joint- Type A

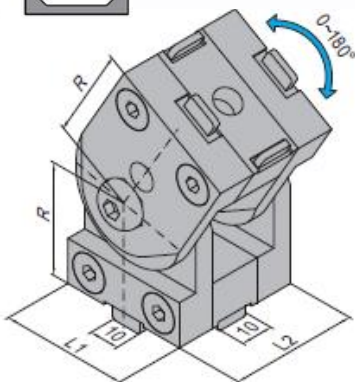

## Joint- Type B

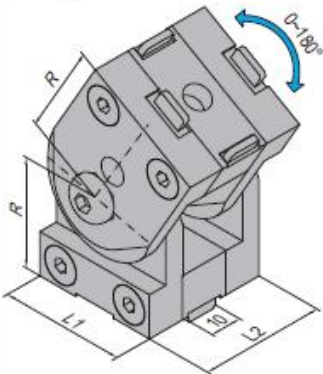

## Joint- Type C

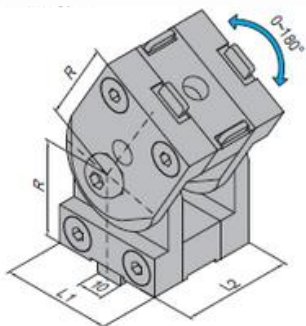

Description	L1 (mm)	L2 (mm)	R (mm)	Fastening Set	Mass (g)	Part No.
Joint-Type A- 4040	40	40	35	2x <b>FX</b>	560	8.31.4040A
Joint-Type A- 4060	40	60	37.5		680	8.31.4060A
Joint-Type A- 4545	45	45	35	2x <b>FX</b>	650	8.31.4545A
Joint-Type A- 4560	45	60	37.5		800	8.31.4560A
Joint-Type B- 4040	40	40	35	1x <b>FD</b> +1x <b>FX</b>	575	8.31.4040B
Joint-Type B- 4060	40	60	35		695	8.31.4060B
Joint-Type B- 4545	45	45	37.5	1x <b>FD</b> +1x <b>FX</b>	665	8.31.4545B
Joint-Type B- 4560	45	60	37.5		815	8.31.4560B
Joint-Type C- 4040	40	40	35	1x <b>FD</b> +1x <b>FX</b>	575	8.31.4040C
Joint-Type C- 4060	40	60	35		695	8.31.4060C
Joint-Type C- 4545	45	45	37.5	1x <b>FD</b> +1x <b>FX</b>	665	8.31.4545C
Joint-Type C- 4560	45	60	37.5		815	8.31.4560C

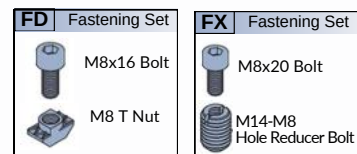

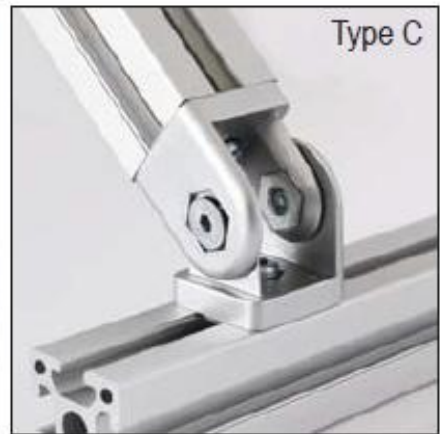
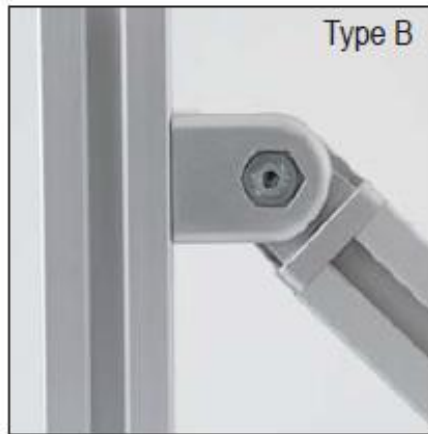
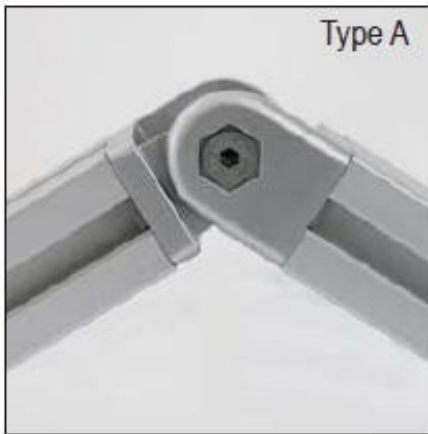

**Material:** Zinc alloy

Usado para conectar perfiles movibles

---

To connect movable profiles



## Joint- Type A

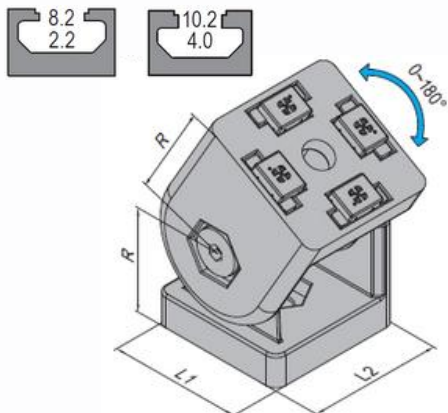

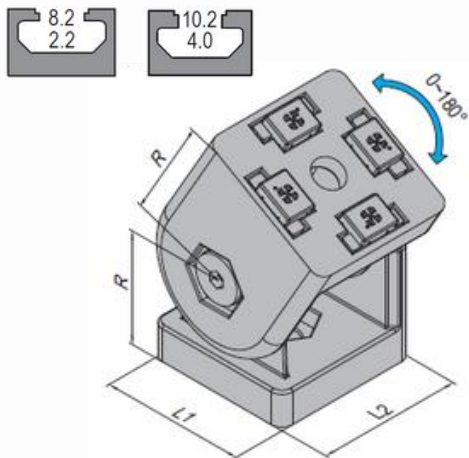

## Joint- Type B



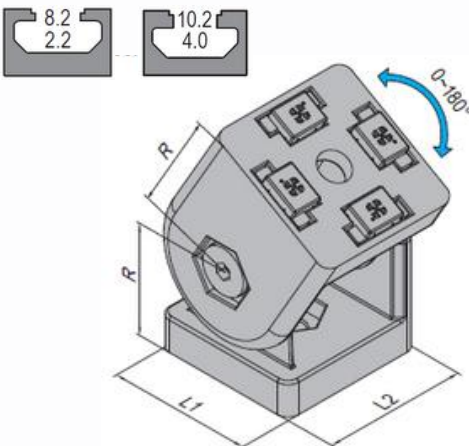

## Joint- Type C



Description	L1 (mm)	L2 (mm)	R (mm)	Fastening Set	Mass (g)	Part No.
Joint-Type A- 3030	30	30	22.5	2xFO	181	8.32.3030A
Joint-Type A- 3030-RH	30	30	22.5		211	8.32.3030A.RH
Joint-Type A- 4040	40	40	30	2xFX	388	8.32.4040A
Joint-Type A- 4040-RH	40	40	30		477	8.32.4040A.RH
Joint-Type A- 4545	45	45	33.5	2xFX	530	8.32.4545A
Joint-Type A- 4545-RH	45	45	33.5		587	8.32.4545A.RH
Joint-Type B- 3030	30	30	22.5	1xFS+1xFO	167	8.32.3030B
Joint-Type B- 3030-RH	30	30	22.5		206	8.32.3030B.RH
Joint-Type B- 4040	40	40	30	1xFU+1xFX	366	8.32.4040B
Joint-Type B- 4040-RH	40	40	30		437	8.32.4040B.RH
Joint-Type B- 4545	45	45	33.5	1xFX+1xGO	510	8.32.4545B
Joint-Type B- 4545-RH	45	45	33.5		577	8.32.4545B.RH

<b>FS</b> Fastening Set  M6x10 Bolt M6 T Nut	<b>FO</b> Fastening Set  M6x16 Bolt M12-M16 Hole Reducer Bolt	<b>FU</b> Fastening Set  M8x12 Bolt M8 T Nut
--	---	--

<b>FX</b> Fastening Set  M8x20 Bolt M14-M8 Hole Reducer Bolt	<b>GO</b> Fastening Set  M8x16 Bolt M8 T Nut
---	--

Description	L1 (mm)	L2 (mm)	R (mm)	Fastening Set	Mass (g)	Part No.
Joint-Type C-3030	30	30	22.5	1xFS+1xFO	167	8.32.3030C
Joint-Type C-3030-RH	30	30	22.5		206	8.32.3030C.RH
Joint-Type C-4040	40	40	30	1xFU+1xFX	366	8.32.4040C
Joint-Type C-4040-RH	40	40	30		437	8.32.4040C.RH
Joint-Type C-4545	45	45	33.5	1xFX+1xGO	510	8.32.4545AC
Joint-Type C-4545-RH	45	45	33.5		577	8.32.4545C.RH

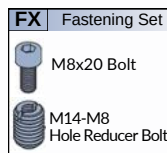
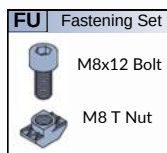
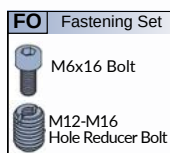



**Material:** Aluminium

Cuando el marco del perfil tiene un leve dobléz causado por el peso, el frame joint se usa con conectores especiales para aumentar la estabilidad del marco.

---

When the profile frame is with big span and there is slight bending caused by self load, the frame joint shall be used with special connectors for cross connection to enhance the stability of the frame

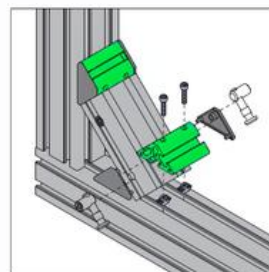
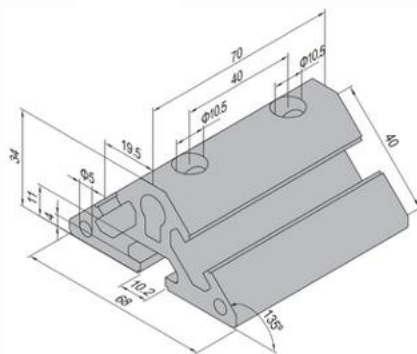
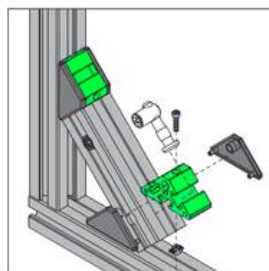
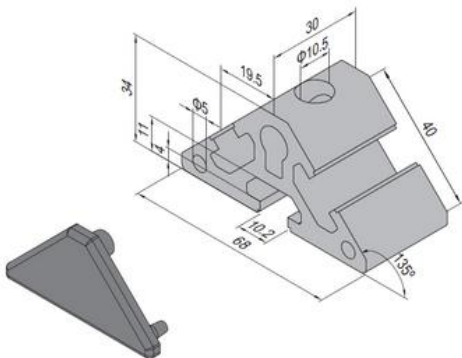

Description	Fastening Set	End Cap	Mass (g/pcs)	Part No.
PG40-4040	1x <b>CB</b>	2	95	8.41.4040
PG40-4080	2x <b>CB</b>	2	192	8.41.4080

Note: Anchor Connector to be ordered separately refer to P. 3-03 for more detail

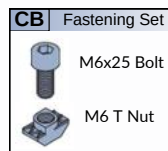



**Material:** Adaptor- Steel, zinc plated  
End cap- Black PA6

Conector especial para instalaciones rápidas de  
deslizadores

---

Special connector for quick roller installation





Telescopio estan compuestas de perfil estructural, perfil telescópico y elementos de conexión. El alcance es de 50-500mm

Telescope Unit are composed of strut profile, telescopic profile and connecting elements. The stroke of telescope unit is 50-500mm

## Telescope Unit-3030

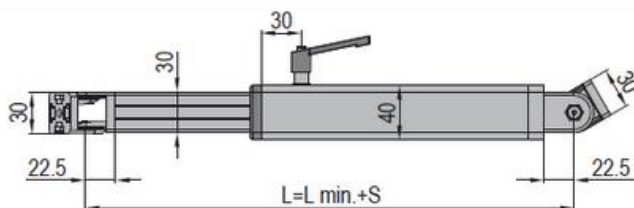
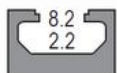



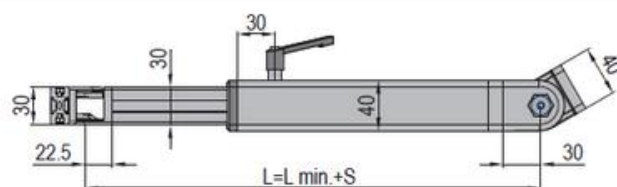

## Telescope Unit-3040



Description	Fastening Set	Stroke S(mm)	L min. (mm)	Mass (g)	Part No.
Telescope Unit-3030 (set)	2xFS	50≤S≤200	369	1.23	8.61.40.3030.01.ST
	2xFS	200<S≤350	519	1.43	8.61.40.3030.02.ST
	2xFS	350<S≤500	669	1.94	8.61.40.3030.03.ST
Telescope Unit-3040 (set)	1xFS+1xFU	50≤S≤200	377	1.42	8.61.40.3040.01.ST
	1xFS+1xFU	200<S≤350	527	1.62	8.61.40.3040.02.ST
	1xFS+1xFU	350<S≤500	677	2.13	8.61.40.3040.03.ST

Note: Offer per set. If there is any special requirement on the stroke, please contact us.

FS	Fastening Set	FU	Fastening Set
	M6x16 Bolt		M8x12 Bolt
	M6 T Nut		M8 T Nut

# TIPO DE PERFORACIÓN

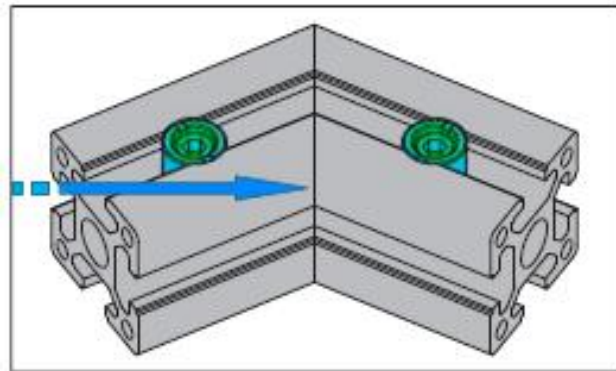
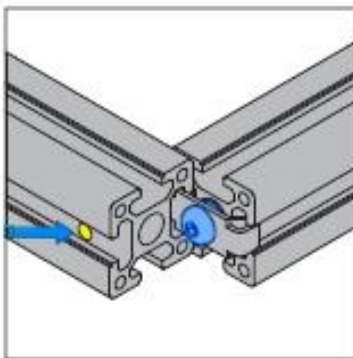
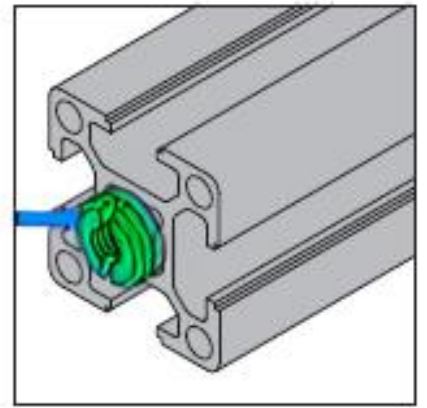
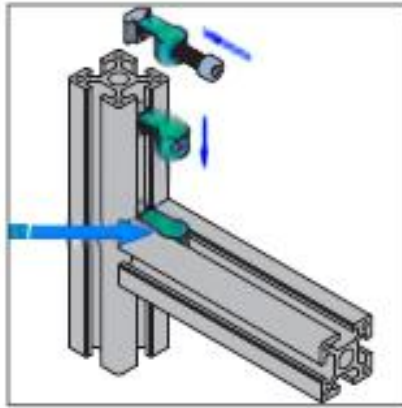
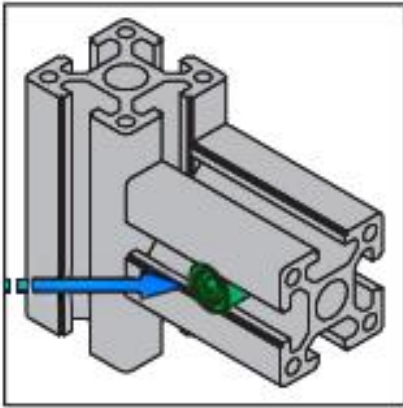

Machining Name	Application
Dowel Bore	Anchor Connector
Inner Connector Bore	Butt Connector
Screw Thread Bore	Screw Connector
Cross Bore	Screw/ End Connector
Angle cut T	Anchor Connector



Classification		Inner connector bore			
		Left		Right	
		Horizontal	Vertical	Horizontal	Vertical
Code		LIH	LIV	RIH	RIV
Square					
		—		—	
		—		—	
			—		—
Rectangle					
Arc			—		—

Example A: 1. 11. 40.040040.04H-200-LIH/RIH

Example B: 1. 11. 40.040080.06H-200-LIV/RIH

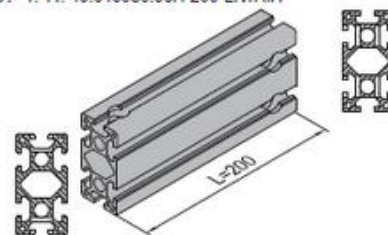
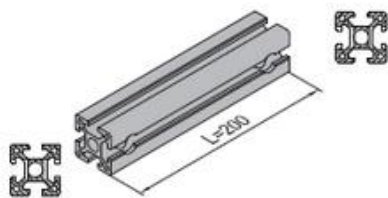

Classification		Screw thread bore					
		Left		Right		Left+Right	
Code		LSP	LMP	RSP	RMP	WSP	WMP
Square							
			—		—		—
			—		—		—
			—		—		—
Rectangle							
Arc			—		—		—

Example A:  
1. 11. 40.040040.04H-200-LSP

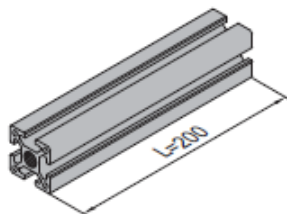

Example B:  
1. 11. 40.040080.06H-200-WSP

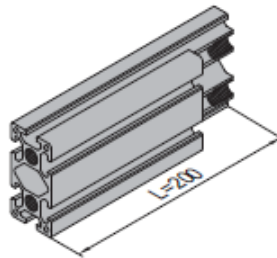

Example C:  
1. 11. 40.040040.04H-200-LMP

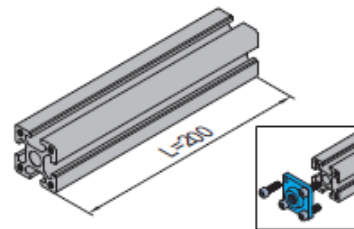

Classification		Cross bore					
		Left			Right		
Code		Horizontal	Vertical	H+V	Horizontal	Vertical	H+V
		<b>LCH</b>	<b>LCV</b>	<b>LCP</b>	<b>RCH</b>	<b>RCV</b>	<b>RCP</b>
Square							
Rectangle							









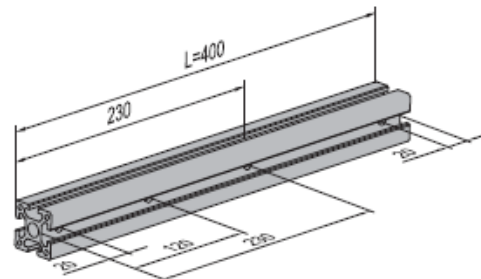





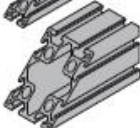
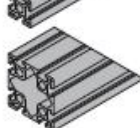



Specified crossing bore code

**LC□/RC□-A□L-B□L...Z□L**



Example: 1. 11. 40.040040.04H-400-LCH/RCH-AH120-BP230

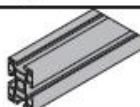
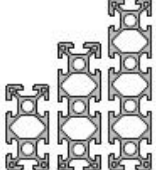

Classification		Angle cut	
		Left	Right
Code		LCT(LAT,LBT,LDT)	RCT(RAT,RBT,RDT)
Square			
			
			
			
			
Rectangle			
			

Specified cutting angle code

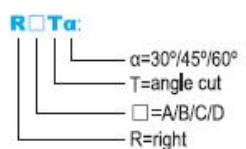
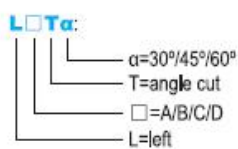

Example: 1. 11. 40.040080.06H-300-LDT45°/RDT45°

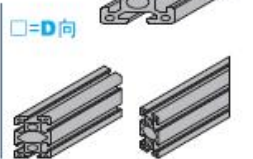
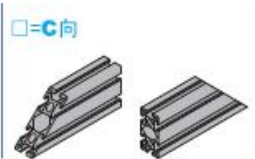
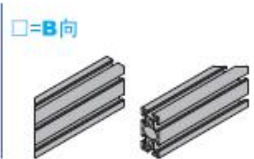
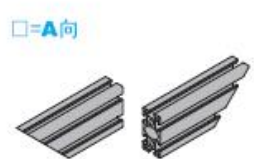
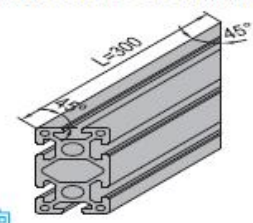

# CATÁLOGO 2025

Visita nuestra página web



DISENTEC CORPORATION  
11395 James Watt Dr.  
Suite A12, El Paso, TX 79936



El Paso, TX, USA +1 915 591 1711  
Cd. Juarez, Chih, MEX +52 656 501 5618



sales@disentec.com  
admin@disentec.com